



5/21/2025

KVS Belt Scale Interface

Rice Lake SCT-4XD



KASKASKIA VALLEY SCALE CO.

Kaskaskia Valley Scale Co. Setup and Calibration Manual

ver. 25.15.25.01

Rice Lake SCT-4XD Belt Scale Integrator



KVS SCT Belt Scale Remote Interface



Applicable to:

Scale Integrator, Rice Lake part numbers:

225171 Indicator, SCT-4XDAN 4 channel weight transmitter with Belt Scale Integrator firmware and Analog Output. Digitizer only.

225172 Indicator, SCT-4XDMB 4 channel weight transmitter with Belt Scale Integrator firmware and Modbus TCP. Digitizer only.

225173 Indicator, SCT-4XDPN 4 channel weight transmitter with Belt Scale Integrator firmware and ProfiNet. Digitizer only.

225174 Indicator, SCT-4XDEIP 4 channel weight transmitter with Belt Scale Integrator firmware and Ethernet IP. Digitizer only.

Human Machine Interface, Automation Direct part numbers:

CM5-T4W 4in display Color TFT LCD, Ethernet, Serial, NEMA 4/4X

CM5-T7W 7in display Color TFT LCD, Ethernet, Serial, NEMA 4/4X

CM5-RHMI Headless HMI, (1) HDMI output, Ethernet, Serial.

Table of Contents

Belt Scale Integrator Function	5
Configuration Data Descriptions	5
Units of Measure	5
System Data	5
Load cell data	5
Conveyor speed data	5
System Data Sheet	6
Setup	8
Units of Measure	8
System Data	8
Idler Spacing	8
Pivoted Carriages lever ratio	9
Load cell data	10
Conveyor speed data	10
Digital Inputs and Outputs	10
Analog Outputs	10
Operation Options	10
Interface Display Screens	11
Main Display	11
KVS Main Menu	12
Initial Setup Menu	13
Scale Setup Menu	14
Scale Setup Menu (continued)	15
Filter Menu	16
Belt Settings and Test Weight Menu	17
Digital Input / Output Settings Menu	18
Calibration Setup Menu	19
Correction Factor Calculator	20
Speed Sensor Calculator	21
Calibration Menu	22
Diagnostic Menu	23
Material Test Calculator	24
Alarm Settings Menu	25

Belt Scale Calibration Procedure	26
Belt Speed Configuration	26
Conveyor Run with Input	26
Conveyor Run always (no Input)	26
Speed Sensor Input	26
Belt Speed Calibration	27
Fixed Belt Speed	27
Belt Speed from a speed sensor	27
SPEED Length Calculator	27
Static Dead Load	28
Zero Belt Calibration	29
Span Calibration	30
Correction Factor Direct Entry	30
Correction Factor Span Calibration	30
Correction Factor Material Test	31
Material Correction Test Weight Factor	32
Test Weight Factor Correction without Material Testing	32
Wiring Layout / Rice Lake SCT-4XD	33
Input Output Wiring	34
Analog Output	34
Digital I/O	34
Connection Ports / Automation Direct HMI	35
Wiring Layout / Automation Direct CMore HMI Panel	36
Rice Lake SCT-4XD Direct Entry	37
Parameter Description	37
Rice Lake SCT-4XD Specifications	39
Automation Direct HMI Panel Specifications	40

Belt Scale Integrator Function

The Rice Lake SCT-4X controller is an independent belt scale controller equipped with 4 load cell input channels that can accommodate up to 4 load cells per channel. It features 2 digital inputs and 2 digital outputs. The belt speed signal can be configured either as a fixed speed, determined by a “Run” input, or as a variable speed through a pulse signal from a speed sensor. Additionally, the SCT-4X includes an optional analog output which can be set to represent the rate of flow, belt loading, or belt speed. Other available configurations for the SCT-4X include fieldbus outputs such as Ethernet/IP, PROFINET, and Modbus TCP/IP.

Prior to configuration the following data will be required.

Configuration Data Descriptions

Units of Measure

US (Imperial), or Metric units of measure.

System Data

Conveyor capacity: pounds, kilograms, short tons, or metric tons per hour.

Maximum belt speed: feet per minute or meters per second.

Idler spacing to determine loading.

Scale carriage spacing to determine lever ratio

Test weight load and spacing to determine lever ratio.

Conveyor angle of incline.

Load cell data

Number of load cells, load cell capacity and Load cell sensitivity and controller load cell channels.

Cable distance from load cells to SCT-4X controller to determine required sense wiring.

Conveyor speed data

Fixed speed from (Run) input or speed sensor.

Speed sensor pulses per revolution and pulley diameter.

Belt Length and circuit time.

System Data Sheet

Units of Measure

1. _____ (US), _____ (Metric)

System Data

2. _____ Conveyor capacity: (pounds), (kilograms), (short tons), (metric tons) per hour.
3. _____ Maximum belt speed: (fpm), (M/Sec).
4. _____ Conveyor angle in degrees.

Carriage Spacing

5. _____ Number of scale carriage idlers. (1,2,3, or 4).
6. _____ Idler spacing (inches), (millimeters).
7. _____ Pivot to Idler spacing (inches), (millimeters). Take average spacing for multiple idlers.
8. _____ Pivot to Load cell spacing (inches), (millimeters).
9. _____ Pivot to Test Weight spacing (inches), (millimeters).

Load cell data

10. _____ Individual Load cell capacity in pounds or kilograms from load cell data sheet.
11. _____ (1-4) Load cell channels used.
12. _____ Total Load cell capacity per channel in pounds or kilograms.
13. _____ Average Load cell sensitivity in mV / V from load cell data sheet.

Conveyor speed data

14. _____ (Fixed Speed from Run Input), or _____ (Speed Sensor)
15. _____ Belt Length for one complete revolution of belt travel in feet or meters.
16. _____ Circuit time for one complete revolution of belt travel in seconds.
17. _____ Maximum Belt Speed in Feet per Minute or Meters per second.
18. _____ Speed sensor pulses per revolution.
19. _____ Speed sensor pulley diameter in inches or millimeters.

Digital Inputs and Outputs

20. _____ Digital Input 1 Definition.
21. _____ Digital Input 2 Definition.
22. _____ Digital Output 1 Definition.
23. _____ Digital Output 2 Definition.
24. _____ Digital Output 1 (Normally Open) or (Normally Closed).
25. _____ Digital Output 2 (Normally Open) or (Normally Closed).
26. _____ Remote Totalizer Output division size.
27. _____ Remote Totalizer Output pulse width timing.

Analog Outputs

- 28. _____ Analog output mode. (Rate of flow), (Belt Loading) or (Belt Speed)
- 29. _____ Analog output Signal Range. (0- 20 mA), (4-20 mA), (0 –10 VDC), (1-5 VDC).
- 30. _____ Minimum analog output count.
- 31. _____ Maximum analog output count.

Operation Options

- 32. _____ Zero Calibration Range Limit %
- 33. _____ Auto Zero Calibration Range Limit %.
- 34. _____ Auto Zero Calibration Track %.
- 35. _____ Dead Band %.
- 36. _____ Rate Active within Dead Band (Yes), (No).
- 37. _____ Store Total and Reset Total with power loss (Yes), (No).
- 38. _____ Enable Negative Total and Reset Total values.

Setup

Units of Measure

The scale can be set to Imperial or Metric units for the totals, rate of flow, loading and belt speed.

System Data

The Conveyor capacity is rated in pounds, kilograms, short tons, or metric tons per hour.

The maximum belt speed is measured in feet per minute or meters per second.

The conveyor angle is measured in degrees of inclination at the scale carriage.

Idler Spacing

Distance between the idlers before and after the scale carriage idlers divided by the number of idlers on the scale +1.

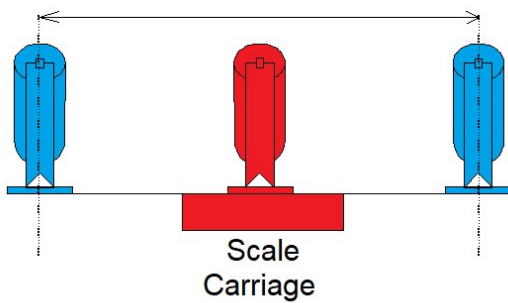

For a scale carriage with (1) scale idler and 96.0" between idlers before and after scale.

96.0" / (1 + 1) = 48.0" idler spacing.

For a scale carriage with (2) scale idlers and 144.0" between idlers before and after scale.

144.0" / (2 + 1) = 48.0" idler spacing.

Pivoted Carriages lever ratio

Only required for pivoted carriages. Direct loaded carriages have a lever ratio and weight ratio of 1.0000.

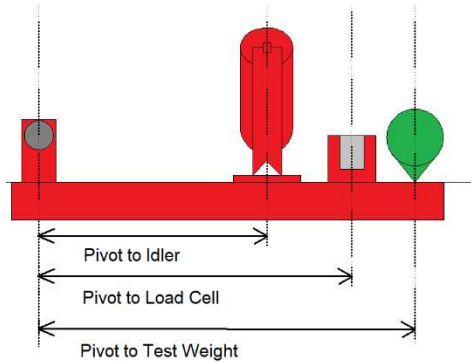

The Pivot to Idler spacing is entered in inches or millimeters. For multiple idlers on a scale carriage, take the average spacing of all idlers on the carriage.

A scale carriage with an idler 24" from the pivot and an idler at 72" from the pivot would have a pivot to idler spacing of 48".

The Pivot to Load cell spacing is entered in inches or millimeters.

Pivot to Test Weight spacing is entered in inches or millimeters. For multiple test weights on a scale carriage, take the average spacing of all weights to be used on the scale.

Load cell data

Each load cell channel supports up to four 350 Ω load cells. Load cell channels can be wired for individual or multiple load cells. Up to sixteen load cells can be supported. All load cells must be of the same nominal capacity and sensitivity.

The SCT-4X can use at least one or up to 4 Load cell channels. Unused channels are disabled.

The load cell capacity entered is the sum of load cells in pounds or kilograms connected to each channel.

The load cell sensitivity is the average of all load cells in millivolts per Volts in the scale from the load cell data sheets.

Conveyor speed data

39. _____ (Fixed Speed from Run Input), or _____ (Speed Sensor)
40. _____ Belt Length for one complete revolution of belt travel in feet or meters.
41. _____ Circuit time for one complete revolution of belt travel in seconds.
42. _____ Maximum Belt Speed in Feet per Minute or Meters per second.
43. _____ Speed sensor pulses per revolution.
44. _____ Speed sensor pulley diameter in inches or millimeters.

Digital Inputs and Outputs

45. _____ Digital Input 1 Definition.
46. _____ Digital Input 2 Definition.
47. _____ Digital Output 1 Definition.
48. _____ Digital Output 2 Definition.
49. _____ Digital Output 1 (Normally Open) or (Normally Closed).
50. _____ Digital Output 2 (Normally Open) or (Normally Closed).
51. _____ Remote Totalizer Output division size.
52. _____ Remote Totalizer Output pulse width timing.

Analog Outputs

53. _____ Analog output mode. (Rate of flow), (Belt Loading) or (Belt Speed)
54. _____ Analog output Signal Range. (0- 20 mA), (4-20 mA), (0 -10 VDC), (1-5 VDC).
55. _____ Minimum analog output count.
56. _____ Maximum analog output count.

Operation Options

57. _____ Zero Calibration Range Limit %
58. _____ Auto Zero Calibration Range Limit %.
59. _____ Auto Zero Calibration Track %.
60. _____ Dead Band %.
61. _____ Rate Active within Dead Band (Yes), (No).
62. _____ Store Total and Reset Total with power loss (Yes), (No).
63. _____ Enable Negative Total and Reset Total values.

Interface Display Screens

Main Display

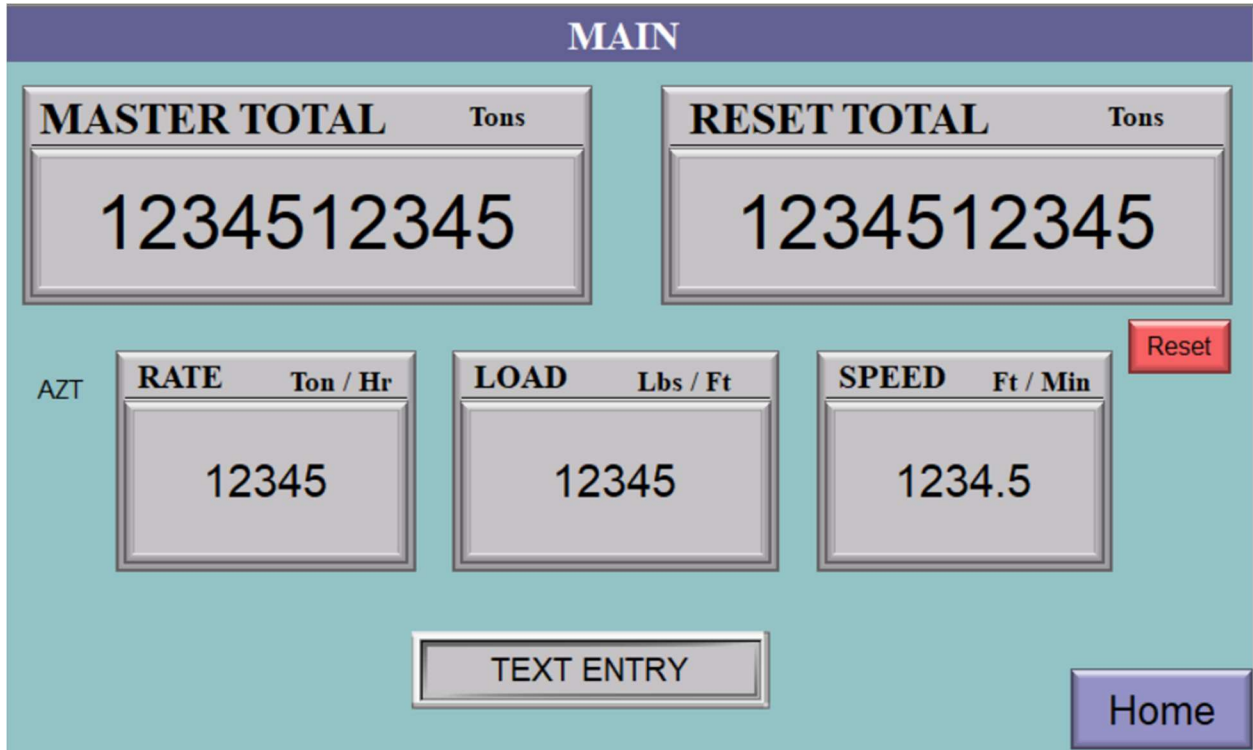

The Main display shows two material totals: Master Total and Reset Total. The Master Total can be reset via the diagnostic menu, while the Reset Total resets with the press of the Reset button.

Both totals can be configured in Pounds, Kilograms, US Short Tons, or Metric Tons.

The Rate of Flow options include Pounds per Hour, Kilograms per Hour, US Short Tons per Hour, or Metric Tons per Hour.

Belt Load settings are available in Pounds per Foot or Kilograms per Meter, and Belt Speed options include Feet per Minute or Meters per Second.

The "AZT" indicator shows if Auto Zero Tracking is enabled and active. Use the Text Entry box to assign a unique scale name to the display.

KVS Main Menu

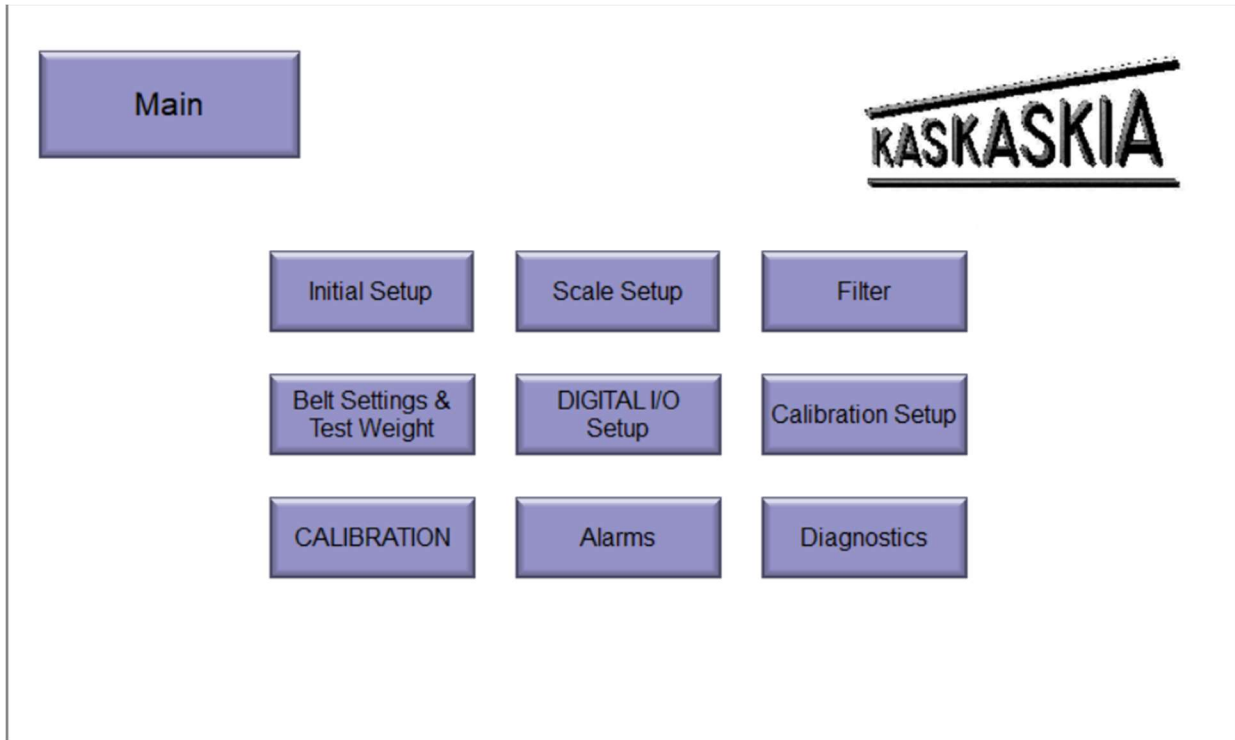

Pressing the “HOME” button on the Main Display screen

Main will return the display to the Main display.

Initial Setup Menu

The screenshot displays the 'INITIAL SETUP' menu with the following elements:

- Enable Edit** button with an **ENABLE** sub-button.
- SYSTEM Units** button with a **SELECTION** sub-button, currently showing **US**.
- CONTROLLER Mode** button with a **SELECTION** sub-button, currently showing **BELT**.
- ANALOG OUT Mode** button with a **SELECTION** sub-button, currently showing **SPEED**.
- ANALOG OUT Type** button with a **SELECTION** sub-button, currently showing **0-10V**.
- Relay OUT Value** button with a sub-button showing **12345**.
- Relay OUT Width** button with a sub-button showing **1234.5 sec**.
- ANALOG Min** button with a sub-button showing **12345**.
- ANALOG Max** button with a sub-button showing **12345**.
- Exit** and **Save** buttons at the bottom right.

Selecting “Enable Edit” to modify settings.

Initial Setup will display settings for:

- Metric / US Imperial weighing units.
- Controller Mode as a Belt Scale or Bulk Slide Flow Meter.
- Analog Output Mode (*if configured*) as Rate, Load or Belt Speed.
- Analog Output Signal Type (*if configured*) as 4-20mA, 0-20mA, 2-10 VDC, or 0-10VDC.
- Relay OUT Value to set output relay representation value.
- Relay OUT Width to set output relay dwell time.
- Analog Out Min (*if configured*) as a scaling factor for minimum analog output.
- Analog Out Max (*if configured*) as a scaling factor for minimum analog output.

Scale Setup Menu

The screenshot shows the 'SCALE SETUP' menu with the following settings:

Parameter	Current Value
Enable Edit	ENABLE
Totalizer Divisions	5 t
Rate Divisions	1 t/h
Load Decimals	1
A/D Channels #	1
MAX Rate	12345
MAX Load	12345
MAX Belt Speed	1234.5
ENCODER 1	ENABLED

Selecting “Enable Edit” to modify settings.

Scale Setup will display settings for:

- Totalizer division size as pounds, kilograms and tons dependent on the Metric or US from the Initial Setup.
- Rate division size as pounds per hour, kilograms per hour and tons per hour dependent on the Metric or US from the Initial Setup.
- Load decimal division to 0, 0.1, 0.01, 0.002. With setting as 0-3.
- A/D Channels as 1-4 for channels in use. Up to 16 load cells may be used with 4 load cells wired in parallel on any one channel.
- Maximum Rate in Rate of Flow Units for belt scale capacity.
- Maximum Load in belt loading for scale carriage capacity.
- Maximum Belt Speed for conveyor drive capacity.
- Encoder 1 Enabled or Disabled as belt speed input on digital input 1.

NEXT (continues Scale Setup)

Scale Setup Menu (continued)

The screenshot displays the 'SCALE SETUP CONTINUED' menu with the following settings:

Parameter	Current Value
Enable Edit	ENABLE
Fixed Belt Speed	1234.5
ZERO Range %	123.4
AUTO ZERO Range %	-12.3
AUTO ZERO Limit %	-12.3
DEAD BAND %	12.3%
RATE in Deadband	Yes / No
Store TOTALS	SELECTION
Negative TOTALS	Yes / No

Navigation buttons: Back, Home

Selecting “Enable Edit” to modify settings.

- Fixed Belt Speed value for a belt scale without speed sensor. Setting at maximum belt speed.
- ZERO Range is a percent limit based on Maximum Rate of flow. The Zero Range will not allow a zero calibration above the limit.
- AUTO ZERO Range is a percent limit based on Maximum Rate of flow. The AUTO Zero Range will disable the AUTO Zero above the limit.
- DEAD BAND Range is a percent limit based on Maximum Rate of flow. The DEAD BAND Range will hold back the Totals below the limit.
- RATE in Deadband will enable (Y) or disable (N) the Rate of flow when the Rate is below the DEAD BAND Range.
- STORE TOTALS if enabled, will retain the Total values after power loss or reset. Set as always, Rate of Flow is above 5%, or never.
- Negative TOTALS if enabled, will allow the Totals to count both Up and down.

Filter Menu

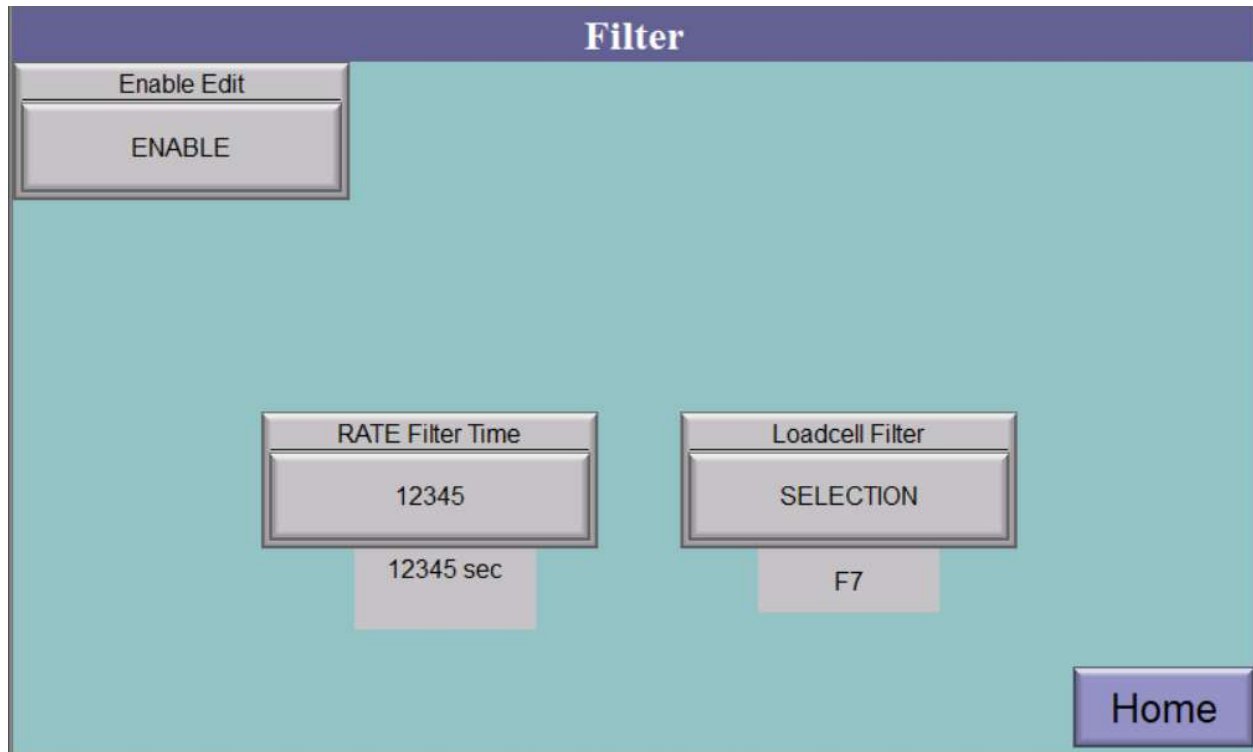

Selecting "Enable Edit" to modify settings.

- RATE Filter Time to average the rate display. Setting in seconds per update.
- Loadcell Filter to average load signal. Setting F1 minimum to F10 maximum.

Belt Settings and Test Weight Menu

BELT SETTINGS AND TEST WEIGHT			
Enable Edit			
ENABLE			
BELT Length	BELT Test Revolutions	Test Weight	WEIGHT Factor
1234.5	12	123.45	-1.234512
1234.5 Ft	12345	123.45 Lbs	-1.234512
WEIGHT Distance	WEIGHT Fixed Time	TEST WEIGHT Delay	
123.45	1234.5 sec.	1234.5 sec.	
123.45 Ft	1234.5 s	1234.5 s	
			Home

Selecting “Enable Edit” to modify settings.

- Belt Length for one revolution of travel.
- Belt Test Revolutions for number of revolutions for zero calibration. Suggest 3 revolutions or 6 minutes duration.
- Total combined test weight applied to scale.
- Weight Factor to correct for lever ratio or material bias. Setting to 1.000000 applies no correction.
- Weight distance in belt travel to sample for test weight calibration. Normally set as a multiple of the belt length.
- Weight Fixed Time is a span calibration timer for scales without a speed sensor input.
- Test Weight Delay allows a settling time before starting span calibration with a test weight.

Digital Input / Output Settings Menu

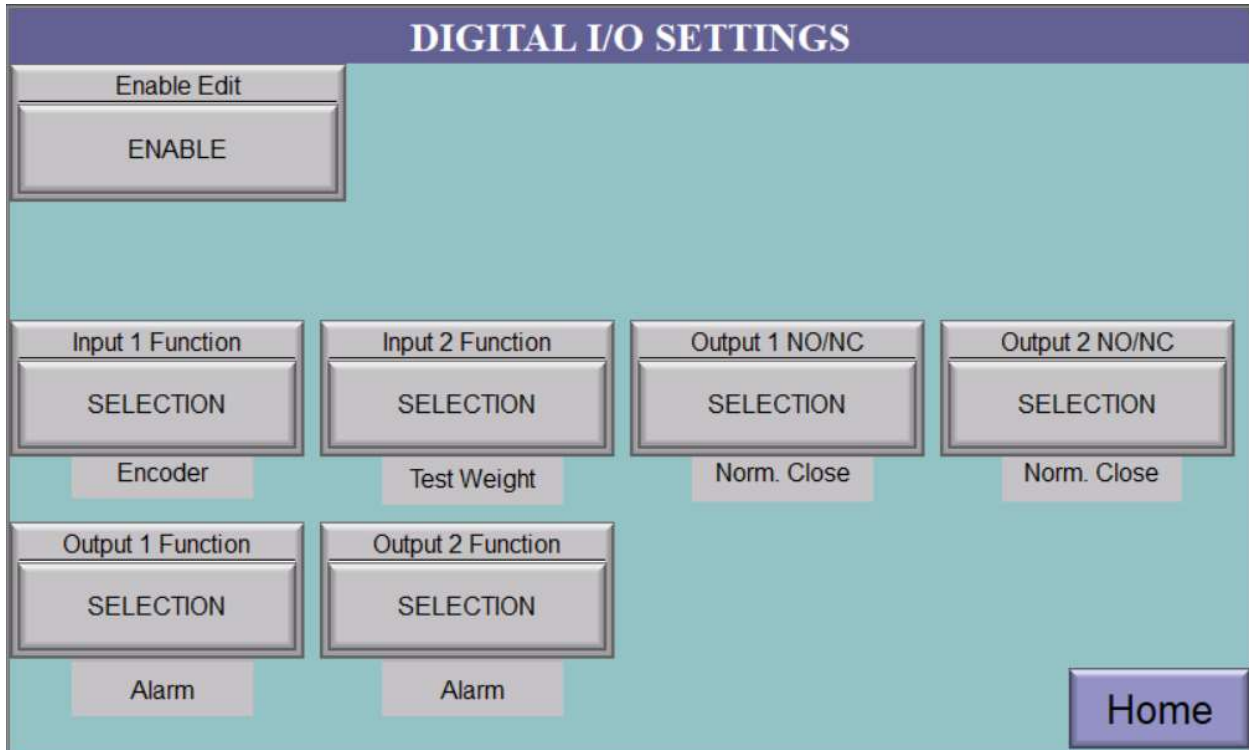

Selecting “Enable Edit” to modify settings.

- Digital Input 1 set as None, Zero key, Tare key, Mode key, Print key, “C” key, Reset Indicator, Keyboard Lock, Run (**use for conveyor run, if no speed sensor**), Enable, Off track, Clear Reset Total, Zero Belt, External Alarm, Test Weight Applied, Encoder (**use for speed sensor**).
- Digital Input 2 set as None, Zero key, Tare key, Mode key, Print key, “C” key, Reset Indicator, Keyboard Lock, Run (**use for conveyor run, if no speed sensor**), Enable, Off track, Clear Reset Total, Zero Belt, External Alarm, Test Weight Applied, Encoder (**use for speed sensor**).
- Output 1 Normally Open / Normally Close.
- Output 2 Normally Open / Normally Close.
- Output 1 set as None, Belt Running, Off Track Alarm, System Alarm, Locked, Air Purge (**Bulk Slide**), Totalizer (**use for Remote Total Output**), No Speed Alarm, Flow in Deadband Alarm, Drop Test weight.
- Output 2 set as None, Belt Running, Off Track Alarm, System Alarm, Locked, Air Purge (**Bulk Slide**), Totalizer (**use for Remote Total Output**), No Speed Alarm, Flow in Deadband Alarm, Drop Test weight.

Calibration Setup Menu

The screenshot displays the 'CALIBRATION SETUP' menu with the following settings and values:

Setting	Value
Enable Edit	ENABLE
Lever Ratio	CALCULATE
SPEED Length	CALCULATE
LOADCELL Capacity	1234.512
LOADCELL mV/V	1.23451 mV/V
CORRECTION FACTOR	1.234512
SPEED Pulse Len	1.2345
IDLER Weigh Length	12345
BELT ZERO Time	123.45 sec
Conveyor ANGLE	12.3 °

At the bottom right, there are 'Exit' and 'Save' buttons.

Selecting "Enable Edit" to modify settings.

- Load cell capacity entered as total load cell capacity on all channels.
- Load cell sensitivity entered as average mV per Volt for all load cells.
- Correction Factor to adjusted material bias. Setting 1.000000 applies no correction.
- CALCULATE Lever Ratio opens another menu to adjust for pivoted carriage scales.
- SPEED Pulse Length adjusts the speed sensor signal into belt travel distance.
- CALCULATE SPEED Length opens another menu to adjust the belt speed.
- IDLER Weigh Length adjusts load into belt loading. Enter idler spacing x number of weigh idlers.
- BELT ZERO time is timing for zero belt calibration without a speed sensor.
- Conveyor Angle adjusts load signal for indirect loading at the load cells.

Correction Factor Calculator

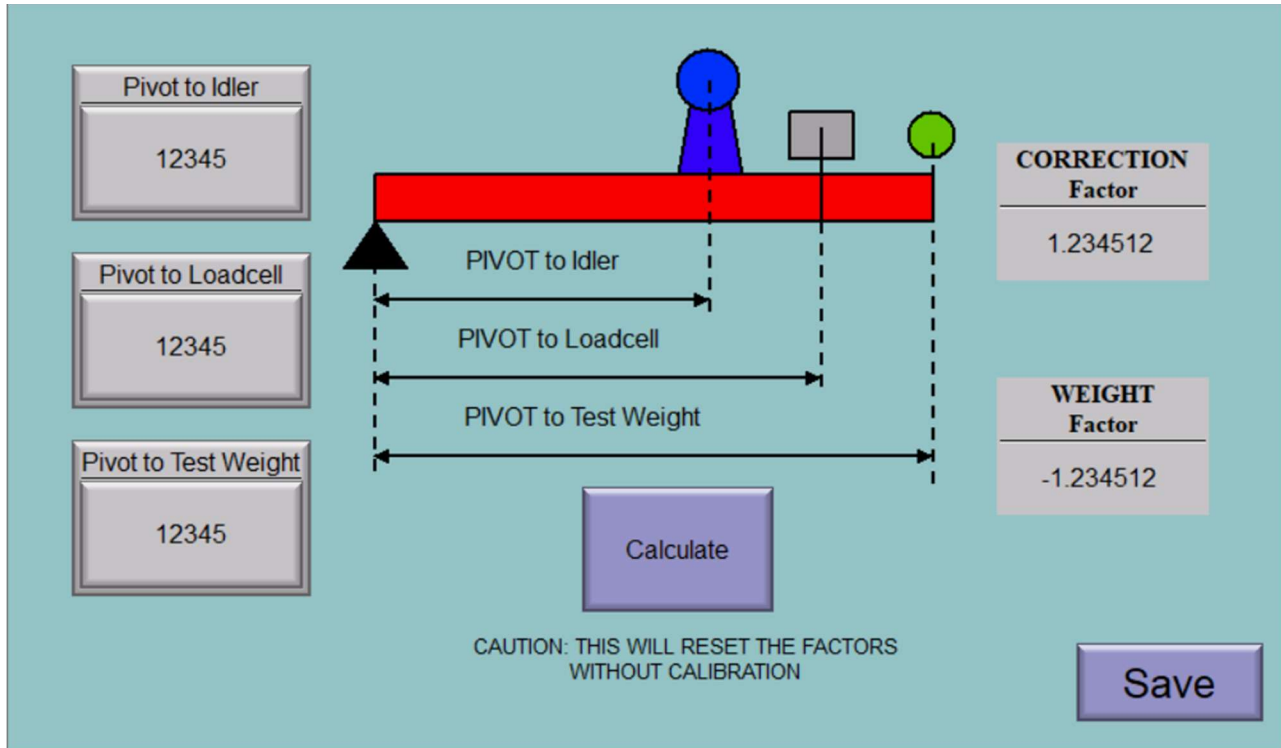

Lever Ratio and Test Weight Correction Factor Calculator

Pressing the "CALCULATE" button will set correction factors based upon the dimensions entered.

NOTE: The correction factors will be set to theoretical values. Further calibration should be performed.

The Test Weight Factor may require adjustment based upon material testing.

Speed Sensor Calculator

The screenshot displays a graphical user interface for a speed sensor calculator. It features several input and output fields and control buttons. The input fields are: 'Targets / Rev' with the value 1234, 'Pulley Diameter' with the value -12.345, and 'In / pulse' with the value 1.2345. The output fields are: 'Max SPEED' with the value 1234.5 Ft/Min and 'Current SPEED' with the value 1234.5 Ft/Min. The control buttons are: 'Calculate', 'Adjust Speed to Max', and 'Exit'.

SPEED Length Calculator

Pressing the “CALCULATE” button when SPEED Pulse Length is set to 0, the display will prompt for targets per revolution and pulley diameter. The result is the SPEED Pulses per length.

Pressing the “CALCULATE” button when SPEED Pulse Length is > 0 , the display will show the current speed and the expected maximum speed. Pressing “Adjust Speed to Max” will adjust the SPEED Pulses per length to register maximum speed.

Calibration Menu

CALIBRATION PROCEDURE			
mV AVERAGE -12.345	LOAD Lbs / Ft 12345	Zero Cal Progress 123 %	Zero Calibration
Test Weight STATUS Accepted	RATE Ton / Hr 12345		Span Calibration
Test Total Lbs 12345			Calibration Abort
Correction Factor 1.234512			Save

Calibration Menu

Upon entering the calibration menu, the SCT-4X will disable the Auto Zero tracking, Deadband and Totalizer Output relay.

The Master Total and Reset Total weight resolution will change to 5 lbs. (or 5 kilograms, if set for Metric).

- Zero Calibration performs an empty belt calibration.
The belt must be running without material.
The belt loading must be within the calibration zero range as set in the Scale Setup menu.
The Zero Calibration reference is set in the Diagnostic menu “Set Zero Reference”.
- Span Calibration performs a known load calibration from a test weight applied to the scale.
The span calibration will pause until load is registered and the Test Weight Delay has expired.
The Test Load is determined based on the Weight Distance, Idler Spacing, and Test Weight.
The test weight parameters are entered in the Belt Settings and Test Weight menu.
- Calibration Abort will cancel the test.
- Save will store the calibration changes and return to the Main menu.

Upon leaving the calibration menu, the SCT-4X will enable the Auto Zero tracking, Deadband, and Totalizer Output Relay if previously selected. The Master Total and Reset Total weight resolution will be reset to the previous setting. The Reset Total will be cleared. Any weight registered during the calibration test is accumulated on the Master Total.

Diagnostic Menu

DIAGNOSTICS

mV CHANNEL 1	Belt Status	Alarm Status	Master Total Reset	
-12.345	Dynamic Text	Dynamic Text		
mV CHANNEL 2	Set Zero Reference	Zero mV	Input 1	Input 2
-12.345		-1.23451	Off	Off
mV CHANNEL 3	Material Test	Output 1	Output 2	Analog Out
-12.345		Off	Off	123.45%
mV CHANNEL 4				
-12.345				

Version 25.15.25.01

Home

Diagnostic Menu

- Load cell signal for each enabled channel is displayed.
- Indicator lights indicate the channel is within +/- 39 mV.
- Belt Status indicates current operation.
- Alarm Status indicates alarm and setpoint conditions.
- Set Zero Reference for zero calibration.
- Material Test opens a menu to adjust the scale for a known quantity of material.
- Master Total Reset to clear Master Total to zero.
- Digital IO status for inputs and outputs.
- Analog Out indicates percentage of current output signal.
- Home will return to the Main Menu.

Material Test Calculator

The screenshot displays the Material Test Calculator interface. It features two input fields at the top: "Belt Scale Wt." and "Reference Wt.", both containing the value "123451". To the right of these fields is a "Calculate" button. Below the input fields, the "Material Test Error" is displayed as "-123.45%". Further down, there are two columns of output fields: "CORRECTION FACTOR" (1.234512) and "NEW FACTOR" (1.234512) in the first row; "TEST WEIGHT FACTOR" (-1.234512) and "NEW FACTOR" (1.234512) in the second row. To the right of these output fields are three action buttons: "CONFIRM Span Change", "DECLINE Span Change", and "Adjust Test Weight". At the bottom right is an "Exit" button.

Material Test Adjustment

- Belt Scale Weight defaults to the current Reset Total. The prompt can be changed to another value.
- Reference Weight must be entered from a corresponding reference source.
- Calculating performs the Error Calculation and determines the new correction factor.
- CONFIRM Span Change enters the new correction.
- DECLINE Span Change will abort the material test adjustment.
- Adjust Test weight will correct for a bias between the Material Test calibration and the Test Weight Span calibration.
- Exit will return to the Main Menu.

Alarm Settings Menu

The screenshot shows the 'ALARM SETTINGS' menu with the following configurations:

Setting	Value
Belt Tracking	Off
External Alarm	Off
Rate Overload	Off
Rate In Range	Off
Belt Tracking Alarm Trip	12.3 sec.
External Alarm Alarm Trip	12.3 sec.
Rate Overload Alarm Trip	12.3 sec.
Rate In Range Alarm Trip	12.3 sec.
Rate Overload %	123.4 %
Low Rate	12345
High Rate	12345

A 'Save' button is located in the bottom right corner of the menu.

Alarm Settings

Belt tracking and External Alarms can be enabled for external inputs defined in the Digital I/O menu. The Rate Overload is triggered when the rate of flow exceeds the maximum rate by the entered percentage. The Rate in Range is triggered when the rate falls below the Low Rate or exceeds the High Rate.

- Belt Tracking from external input with alarm dwell time.
- External Alarm from external input with alarm dwell time.
- Rate Overload entered as percentage above the rate capacity with alarm dwell time.
- Rate in Range entered as rate values with alarm dwell time.
- Save will return to the Main Menu.

Belt Scale Calibration Procedure

After entering the initial System Data, the scale will require calibrations for belt speed, zero reference, empty belt zero and dynamic span.

Belt Speed Configuration

The conveyor belt speed can be set up as a fixed speed conveyor RUN input, fixed speed as always on, or as an input from a speed sensor.

Conveyor Run with Input

The input should be wired with the Ground to Input Common and the (+12VDC to +24VDC) going to the input. If you are using a relay, the relay will switch the power and give the input the signal.

An input must be set to RUN. The SCT looks for a change of state. If the input is ON when the SCT gets power, the scale will not run.

The SCT must see the input come ON from an OFF state and OFF from an ON state.

Encoder 1 must be Disabled.

Fixed Speed must be set to the belt speed.

Conveyor Run always (no Input)

If you don't set an input to RUN, the SCT will assume belt speed is ON all the time.

Encoder 1 must be Disabled.

Fixed Speed must be set to the belt speed.

The Main Screen Belt Speed will show Fixed Speed with or without input.

Speed Sensor Input

Input 1 must be set to ENCODER.

Pulses per inch must be set to a value.

Encoder 1 must be Enabled.

Fixed Speed must be 0.

Belt Speed Calibration

Fixed Belt Speed

Fixed belt speed is used on scale systems that do not utilize belt speed sensors. The speed input can be always on or triggered from a conveyor run input. The fixed speed is calculated from the total belt length and time for one revolution and entered as feet per minute or meters per second dependent on the units of measure.

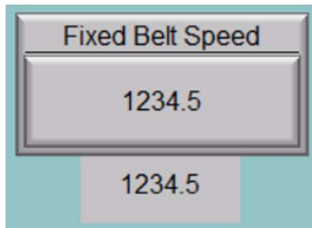

The fixed belt speed is entered in the Scale Setup screen in the secondary menu (Next). If using a speed sensor, this value must be 0.0.

Belt Speed from a speed sensor

Belt speed is calculated based on the diameter of the speed sensor wheel or pulley and the number of targets or encoder pulses per revolution. Enter the resulting multiplier as millimeters or inches per pulse, according to the system's metric or imperial units.

The resultant multiplier can be entered directly into the Calibration Setup Menu for the SPEED Pulse length.

SPEED Length Calculator

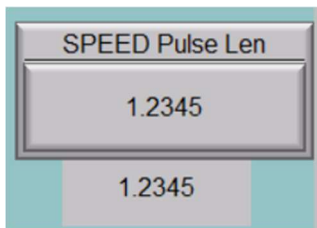

or

SPEED Length Calculator

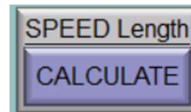

If the SPEED Pulse Length is set as 0, and the SPEED Calculator is pressed a Calculator menu will prompt for the Targets per Revolution and the Pulley diameter. The Calculate button will set the resulting multiplier.

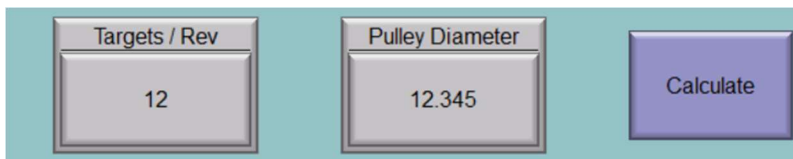

If the SPEED Pulse Length is set > 0, and the SPEED Calculator is pressed the Calculator menu will prompt to tweak the belt speed to match the maximum belt speed as entered in the SCALE SETUP menu.

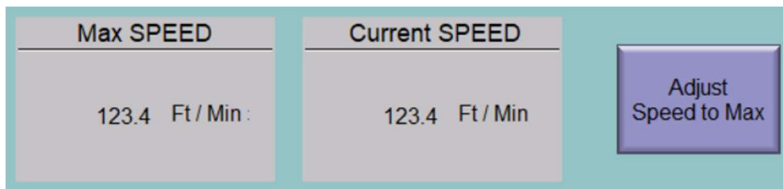
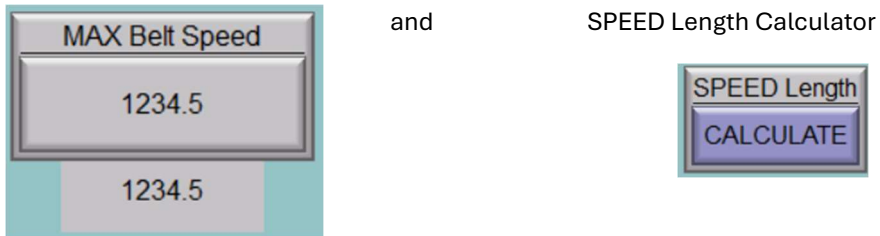

Static Dead Load

The Zero Reference sets a base reference for the empty belt zero calibration. The limits on allowable zero calibrations from the Scale Setup Menu.

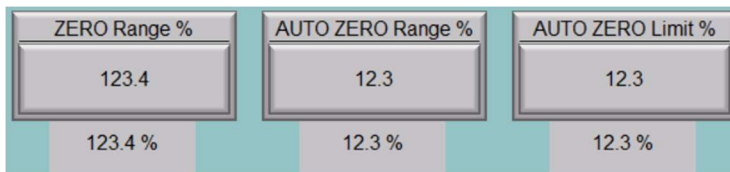

To set the Zero Reference, in the Diagnostic Menu:

With the conveyor belt unloaded and stopped, press the Set Zero Reference button.

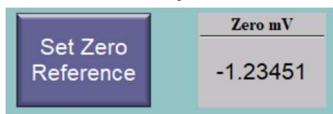

The resultant Zero mV reading will be 20% of the current deadload on the scale.

Zero Belt Calibration

The Zero Calibration sets the empty load point on the scale based on the belt length and number of test revolutions from the Belt Settings and Test Weight Menu.

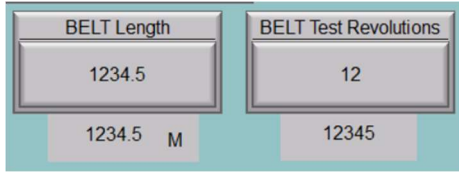

To set the Zero Calibration, in the Calibration Menu:

With the conveyor belt unloaded and running, press the Zero Calibration button.

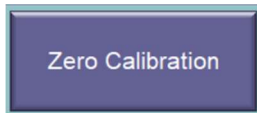

The Calibration Status will change to:

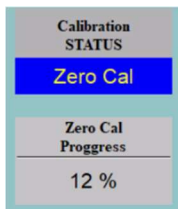

After the timer has elapsed, the results will be displayed.



The Zero Calibration is automatically set after the procedure.

Note: If the Zero Calibration fails to proceed, the loading could be out of the limit, or the belt is stopped. Resetting the Static Dead Load will reacquire the zero limit.

Span Calibration

The Span Calibration establishes a multiplier for the belt loading during motion. The Correction Factor can be entered directly through the Calibration Setup Menu, determined from the Calibration Procedure, or derived from a Material Test.

Correction Factor Direct Entry

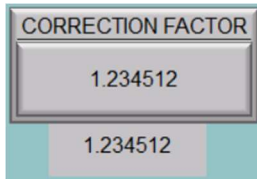

Correction Factor Span Calibration

The Calibration Procedure establishes the Total Test weight by considering the test weight mass, idler spacing, test weight correction factor, and weight distance. This information is configured within the Belt Settings and Test Weight Menu.

To perform the Span Calibration in the Calibration Menu:

With the conveyor belt unloaded and the test weight applied to the scale, press the Span Calibration button.

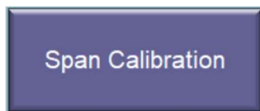

The Calibration Status will change to:

After the timer has elapsed, the results will be displayed.

Calibration STATUS	Total Test Wt. Kg	Test Wt. Registered	Span Error	
Wt Cal	12345	-12345	-123.45 %	
Span Cal Progress	Correction Factor	New Correction Factor	CONFIRM Span Change	DECLINE Span Change
123 %	1.234512	-1.234512		

The Span calibration can be confirmed or declined.

Correction Factor Material Test

The Material Test Procedure involves comparing the weight registered by the belt scale to a known reference weight, which is determined through an external measurement. This data may include the current Reset Total value, or the Total values obtained from multiple observations. The reference weight is ascertained by directly measuring the corresponding material.

To perform a Material Test via the Diagnostic Menu:

With an accumulated Total in the Reset Total register or an acquired Total for comparison, press the Material Test button.



The Menu will change to:

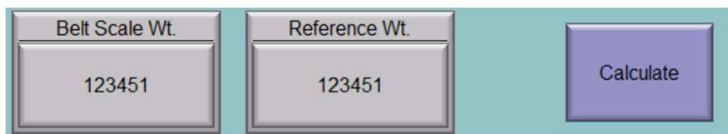

The Belt Scale weight will default to the current Reset Total. If the comparison is based upon a different value, press the Belt Scale Weight and enter the value to be compared.

Enter the Reference Weight value.

Press the Calculate button, the menu will add the options to confirm or decline the material test correction to the Correction Factor.

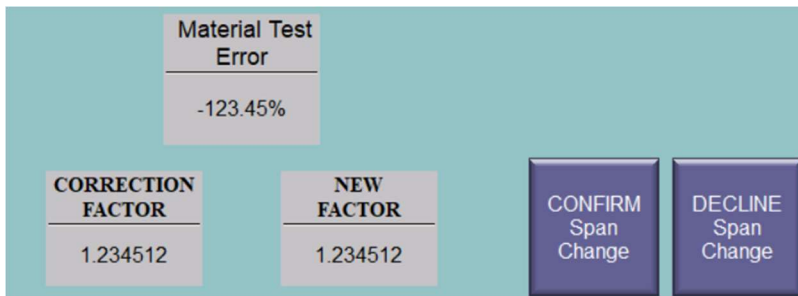

Material Correction Test Weight Factor

Note: The Material Test adjustment to the Correction Factor is independent of the calibration based on test weights. The Test Weight Correction Factor may need adjustment to remove the bias based upon the different calibration methods.

Press the Adjust Test Weight button to apply the Material Test correction to the Test Weight Factor.

TEST WEIGHT FACTOR	NEW FACTOR	Adjust Test Weight
-1.234512	1.234512	

Test Weight Factor Correction without Material Testing

Alternatively, the Test Weight Factor may be adjusted without conducting a material test. The adjustment can be achieved by accessing the Material Test menu and inputting the current Total Test Weight value from the Calibration menu as the Belt Weight, along with the Test Weight Registered value as the Reference Weight. To ascertain the Test Weight Registered value, perform a Span Calibration utilizing the test weights.

Total Test Wt. Kg	Test Wt. Registered	Span Error	
12345	-12345	-123.45 %	
Correction Factor	New Correction Factor	CONFIRM Span Change	DECLINE Span Change
1.234512	-1.234512		

Record and enter the Span Calibration results in the Material Test Menu using the Total Test Weight as the Belt Scale Weight and the Test Weight Registered as the Reference Weight. Decline the Span Change procedure.

Belt Scale Wt.	Reference Wt.	Calculate
123451	123451	

Material Test Error			
-123.45%			
CORRECTION FACTOR	NEW FACTOR	CONFIRM Span Change	DECLINE Span Change
1.234512	1.234512		

Press Adjust to correct the Test Weight Factor. Decline the Span Change in the Material Test Menu.

TEST WEIGHT FACTOR	NEW FACTOR	Adjust Test Weight
-1.234512	1.234512	

Wiring Layout / Rice Lake SCT-4XD

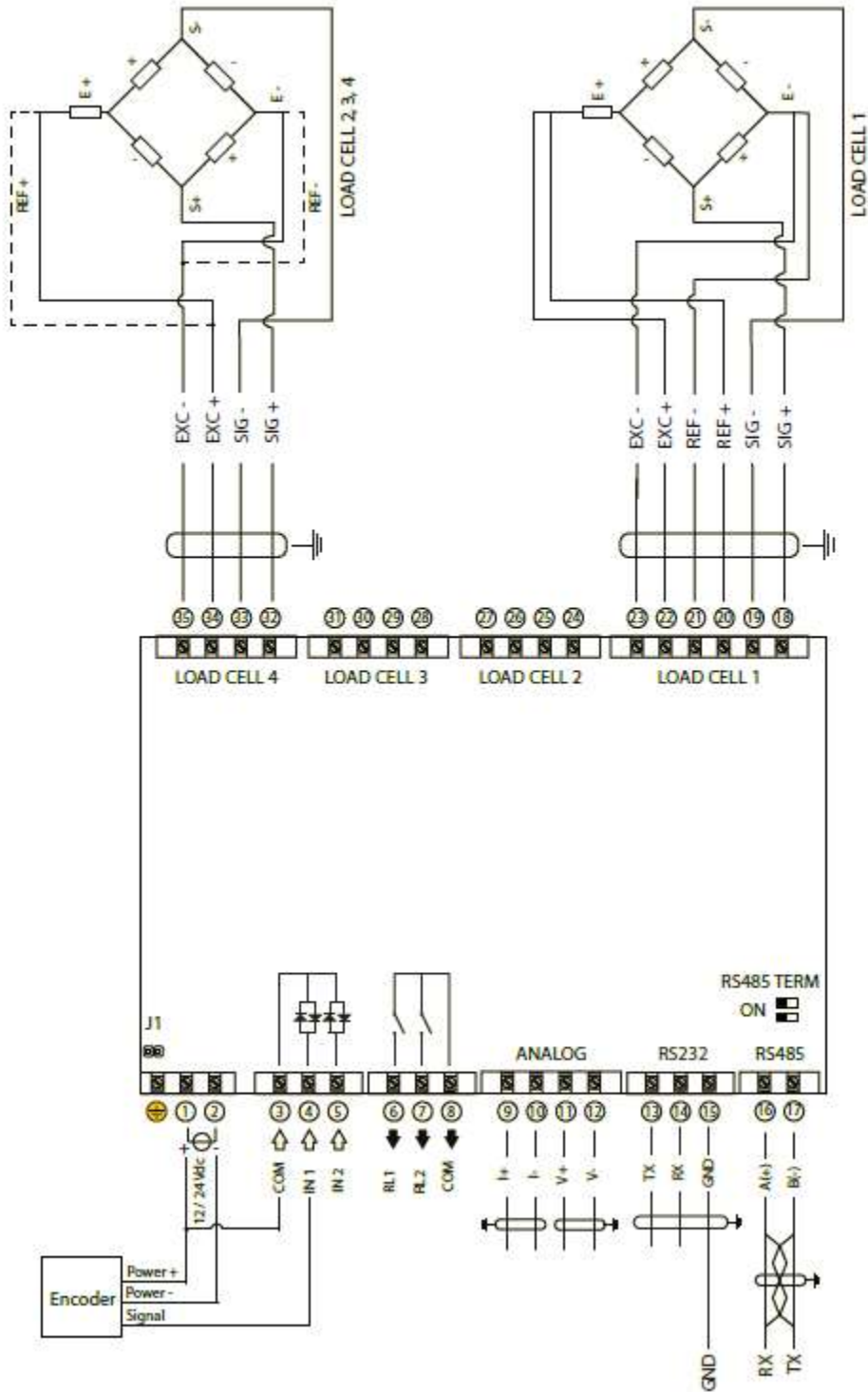

Input Output Wiring

Analog Output

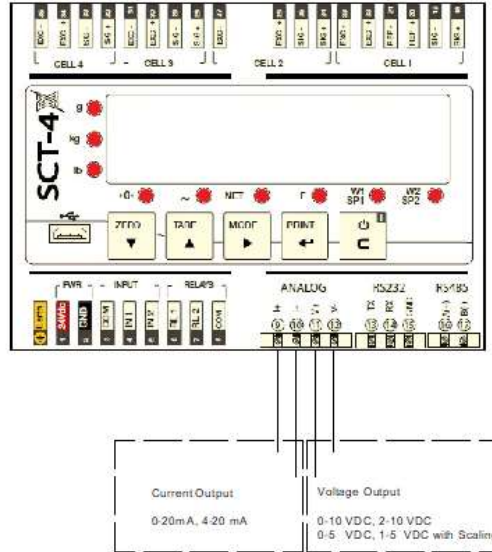

Analog output selectable as Current or Voltage.
 Analog output selectable as Rate, Load, or Belt Speed.
 Sourcing 12 VDC (nominal) from SCT 4X.
 Initial Setup Menu for function and scaling.
 Filter Menu for output filtering.

Digital I/O

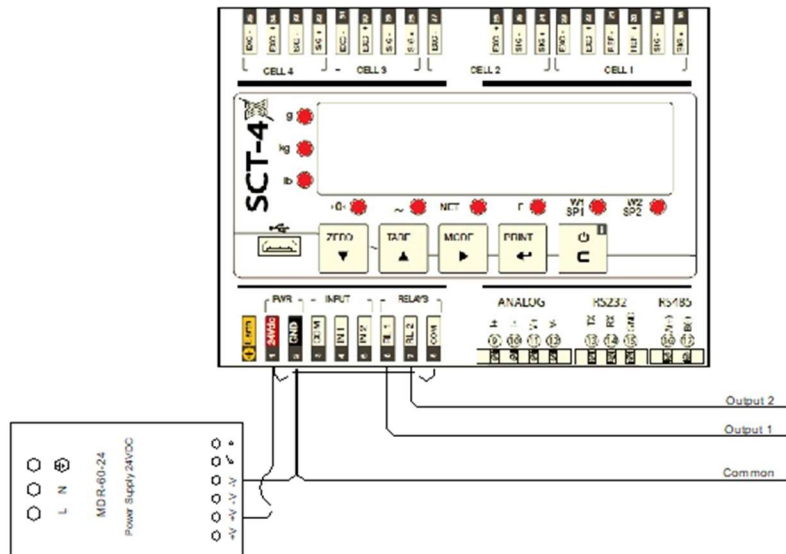

Digital I/O
 Two inputs: 12/24 VDC, 1 kHz
 Two outputs: 150 mA 48 VAC/150 mA 60 VDC

Connection Ports / Automation Direct HMI

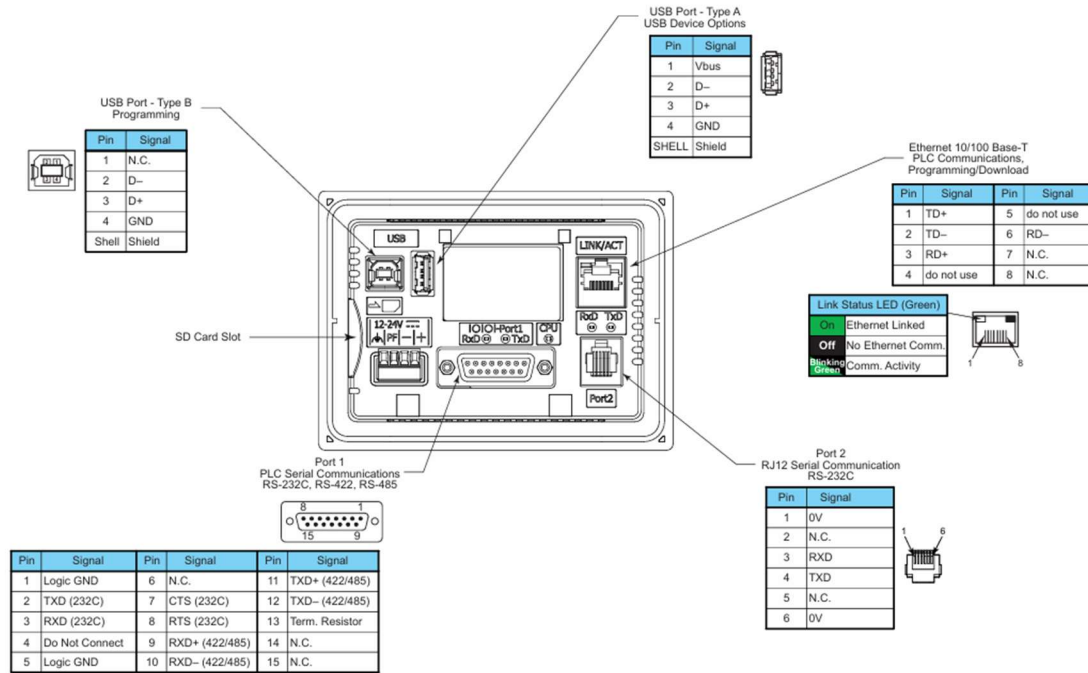

CM5-T4W

The connection between the Rice Lake SCT-4XD and the Automation Direct Interface can be RS232C or RS 485 serial communications from SCT4XD terminal strip to the CM5 DB15 port or the CM5 RJ 12 RS232C port.

The RS232 serial is limited to 50' cable length. The RS485 is limited to 1000' cable length.

The Rice Lake fieldbus integrators #225172, #225173, and #225174 do not have RS 232C ports and must be wired for RS 485.

The SCT-4X is set to communicate using the RS485 port by default. If using the RS 232 port, the communication parameter is changed directly on the SCT-4X and the Automation Direct HMI must be configured through software..

Wiring Layout / Automation Direct CMore HMI Panel

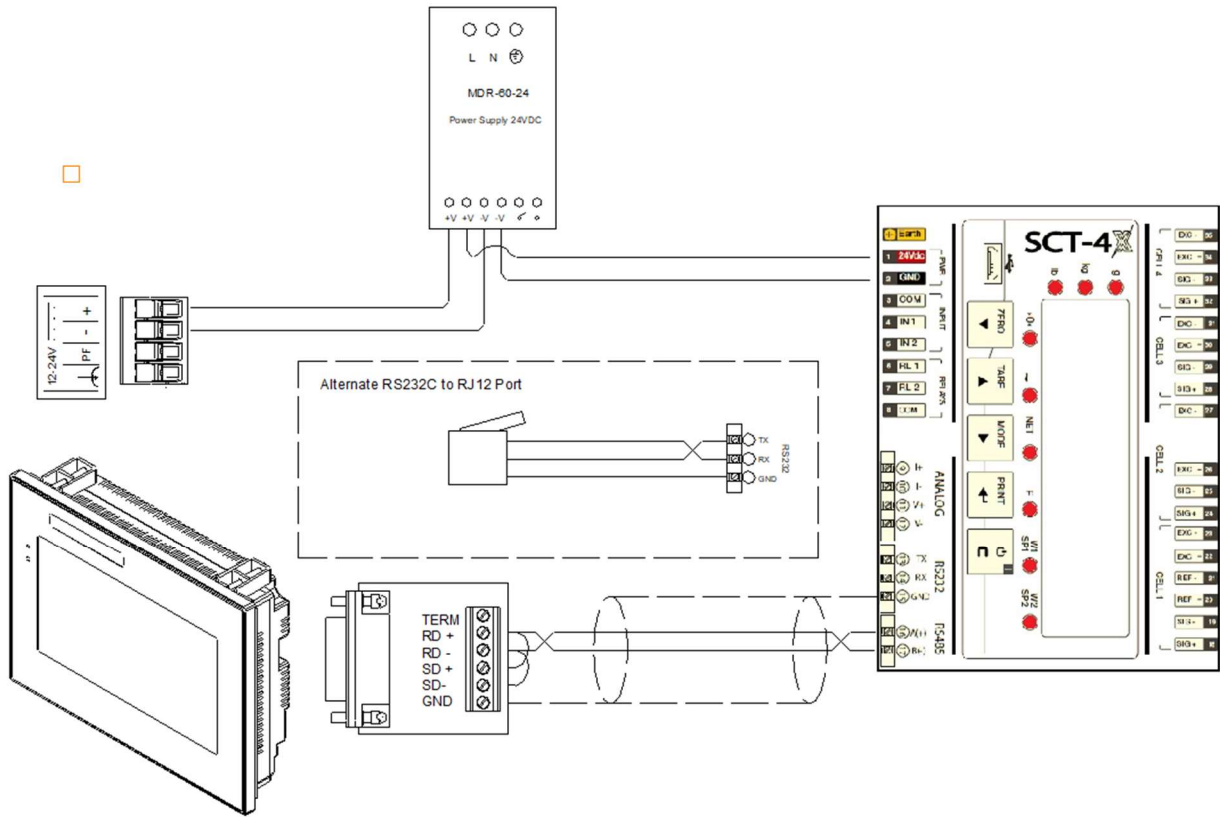

Rice Lake SCT-4XD Direct Entry

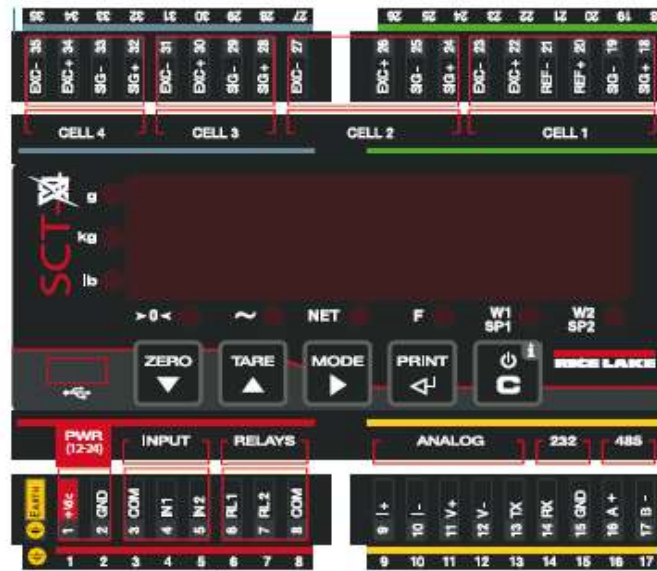

Figure 2-3. SCT-4XD Display

Configuration Menu		Weighing Mode	
▼	Decreases digit Scrolls down	▶	Toggles between belt scale data
▲	Increases digit Scrolls up	◀	Long Press: Accesses user menu
▶	Selects digit to modify	⏻	ON Standby
◀	Enters a step Confirms		
⏻	Clears Exits a step (no save)		

Table 2-1. Key Functions

Direct entry of parameters is possible through the SCT-4X local display. Please refer to the Rice Lake manual “M_SCT-4XD_Integrator_Tech_enUS_RevB.pdf” for detailed description of the direct entry menus.

To access the SCT-4X menu, cycle the power using the (⏻ C) button, hold the (▲ TARE) key while powering up the SCT-4X.

Parameter Description

ini.Set	Initial settings
CEn.PAr	General parameters
bLt.PAr	Belt parameters
CALib	Calibration settings
ALArMS	Alarm settings
Commun	Communication settings
dEFAu	Default settings
diAG	Diagnostics

Example:

Communication menu to enable RS 232.

- Press (▲ TARE , ▼ ZERO) buttons until Commum is displayed.
- Press (⇐ PRINT) to enter the Serial menu.
- Press (⇐ PRINT) to enter the Serial / PC sel menu.
- Press (⇐ PRINT) to enter the Serial / PC sel: 485 / 232 menu.
- Press (▲ TARE , ▼ ZERO) buttons until 232 is displayed.
- Press (⇐ PRINT) to enter, displays responds OK.
- Press (© C), (© C), displays responds SAVE?.
- Press (⇐ PRINT) to Save, displays responds STORE.

SCT4X then restarts with the saved parameter.

Rice Lake SCT-4XD Specifications

Power

12 to 24 VDC

Power Consumption

5 W

Excitation Voltage

5 VDC, 120 mA (up to 16 × 350 ohm cells)

Analog Signal Input Range

±39 mV

Analog Signal Sensitivity

0.3 μ V/graduation minimum

Sample Rate

Single-channel up to 2,600 Hz, software selectable

4 channels up to 100 Hz, software selectable

Analog Output (if equipped)

Opt. isolated, 16-bit

0 to 20 mA, 4 to 20 mA (maximum 350 ohm)

0 to 5 VDC, 0 to 10 VDC (minimum 10,000 ohm)

Digital I/O

Two inputs: 12/24 VDC, 1 kHz

Two outputs: 150 mA 48 VAC/150 mA 60 VDC

Communication Ports

(1) RS-485 half duplex, (1) RS-232 full duplex

1 USB Micro B connector (device)

for PC configuration

Pulse Input

Dual inputs for redundancy

Display

Six-digit 0.31 in (8 mm), red LED

Keys/Buttons

Flat membrane panel, tactile feel

Warranty

One-year limited

Approvals

CE-M EN 4550

Automation Direct HMI Panel Specifications

Specification	Model	CM5-T4W	CM5-T7W	CM5-T10W	CM5-T12W	CM5-T15W	CM5-T22W
Power Consumption		Max. 8 W 0.67 A @12VDC 0.33 A @24VDC	Max. 10W 0.83 A @12VDC 0.42 A @24VDC	Max. 21 W 1.75 A @12VDC 0.88 A @24VDC		Max. 35 W 2.92 A @12VDC 1.46 A @24VDC	Max. 40 W 3.33 A @12VDC 1.67 A @24VDC
Internal Fuse (non-replaceable)		4.0 A			12.0 A		
Altitude		Up to 2000m (6562ft)					
Operating Temperature		0 to 50°C (32 to 122°F) Maximum surrounding air temperature rating: 50°C (122°F) IEC 60068-2-14 (Test Nb, Thermal Shock)					
Storage Temperature		-20 to +60°C (-4 to +140°F) IEC 60068-2-1 (Test Ab, Cold) IEC 60068-2-2 (Test Bb, Dry Heat) IEC 60068-2-14 (Test Na, Thermal Shock)					
Humidity		5-95% RH (non-condensing)					
Environment		For use in Pollution Degree 2 environment, no corrosive gases permitted					
Noise Immunity		(EN61131-2) EN61000-4-2 (ESD), EN61000-4-3 (RFI) EN61000-4-4 (FTB) EN61000-4-5 (Surge) EN61000-4-6 (Conducted) EN61000-4-8 (Power frequency magnetic field immunity) (Local Test) RFI, (145MHz, 440Mhz 10W @ 10cm) Impulse 1000V @ 1µs pulse					
Withstand Voltage		1000VAC, 1min. (FG to Power supply)					
Insulation Resistance		> 10M ohm @ 500VDC (FG to Power supply)					
Vibration		IEC60068-2-6 (Test Fc)					
Shock		IEC60068-2-27 (Test Ea)					
Emission		EN55011 Class A (Radiated RF emission)					
Enclosure		NEMA 250 type 4/4X indoor use only UL50 type 4X indoor use only IP-65 (not tested by UL) (When mounted correctly)					
Agency Approvals		UL61010, E157382 CE (EN61131-2), RoHS (2011/65/EU) and amendment (EU)2015 / 863 CUL Canadian C22.2					



NOTES: 1. The display screen should be cleaned periodically by wiping it with a lint free damp cloth using a mild soap solution. Use a dry or slightly dampened cloth to wipe any dirt from the labels on the back of the panel. Dry all surfaces with a lint free cloth. Do not clean with ammonia based products which are solvents and will damage the face of the panel and the labels
2. The touchscreen is designed to respond to a single touch. If it is touched at multiple points at the same time, an unexpected object may be activated.

UL Satisfaction Ratings	
Model Number	Input Ratings
CM5-T4W	10.2 - 26.4 VDC, Class 2, SELV / LIM, Maximum 8.0 W
CM5-T7W	10.2 - 26.4 VDC, Class 2, SELV / LIM, Maximum 10.0 W
CM5-T10W	10.2 - 26.4 VDC, Class 2, SELV / LIM, Maximum 21.0 W
CM5-T12W	10.2 - 26.4 VDC, Class 2, SELV / LIM, Maximum 35.0 W
CM5-T15W	
CM5-T22W	10.2 - 26.4 VDC, Class 2, SELV / LIM, Maximum 40.0W
Terminal connecting wire size 16 - 24 AWG	
Connecting torque 35 oz-in (2.2 lbf-in) (0.25 Nm)	
Maximum surrounding air temperature rating, 50°C	
For use in Pollution Degree 2 environment	
All interface ports are intended to be directly connected to an isolated secondary circuit	
For use on a flat surface of a type 4X Indoor Use Only enclosure	
 <ul style="list-style-type: none"> Refer to QR Code for link for product handling Use copper conductor only 16 - 24 AWG Strip length - 7mm [0.28"] 	