

Integrators

Milltronics BW500 and BW500/L

Operating Instructions · 10/2012



Milltronics

SIEMENS

Safety Guidelines: Warning notices must be observed to ensure personal safety as well as that of others, and to protect the product and the connected equipment. These warning notices are accompanied by a clarification of the level of caution to be observed.

Qualified Personnel: This device/system may only be set up and operated in conjunction with this manual. Qualified personnel are only authorized to install and operate this equipment in accordance with established safety practices and standards.

Unit Repair and Excluded Liability:

- The user is responsible for all changes and repairs made to the device by the user or the user's agent.
- All new components are to be provided by Siemens Milltronics Process Instruments.
- Restrict repair to faulty components only.
- Do not reuse faulty components.

Warning: Cardboard shipping package provides limited humidity and moisture protection. This product can only function properly and safely if it is correctly transported, stored, installed, set up, operated, and maintained.

This product is intended for use in industrial areas. Operation of this equipment in a residential area may cause interference to several frequency based communications.

Note: Always use product in accordance with specifications.

Copyright Siemens AG 2012. All Rights Reserved

Disclaimer of Liability

This document is available in bound version and in electronic version. We encourage users to purchase authorized bound manuals, or to view electronic versions as designed and authored by Siemens Milltronics Process Instruments. Siemens Milltronics Process Instruments will not be responsible for the contents of partial or whole reproductions of either bound or electronic versions.

While we have verified the contents of this manual for agreement with the instrumentation described, variations remain possible. Thus we cannot guarantee full agreement. The contents of this manual are regularly reviewed and corrections are included in subsequent editions. We welcome all suggestions for improvement.

Technical data subject to change.

MILLTRONICS® is a registered trademark of Siemens Milltronics Process Instruments.

Contact SMPI Technical Publications

at the following address:

Technical Publications
Siemens AG
Siemens Milltronics Process Instruments
1954 Technology Drive, P.O. Box 4225
Peterborough, Ontario, Canada, K9J 7B1
Email: techpubs.smpi@siemens.com

European Authorized Representative

Siemens AG
Industry Sector
76181 Karlsruhe
Deutschland

- For a selection of Siemens Milltronics level measurement manuals, go to: **www.siemens.com/processautomation**. Under Process Instrumentation, select *Level Measurement* and then go to the manual archive listed under the product family.
- For a selection of Siemens Milltronics weighing manuals, go to: **www.siemens.com/processautomation**. Under Weighing Technology, select *Continuous Weighing Systems* and then go to the manual archive listed under the product family.

Table of Contents

Safety Notes	1
The Manual	1
Technical Support	2
Milltronics BW500 and BW500/L	3
Milltronics BW500	3
Milltronics BW500/L	3
Milltronics BW500 and BW500/L features	3
Specifications	5
Installation	9
Dimensions	9
Layout	11
Optional Plug-ins	12
SmartLinux7 Module	12
mA I/O board	12
Interconnection	14
System Diagram	14
Scale – One Load Cell	15
Scale – Two Load Cells	16
Scale – Four Load Cells	17
Scale – Six Load Cells	18
Scale – LVDT	19
Speed	20
Constant Speed (No Sensor)	20
Main Speed Sensor	20
Auxiliary Speed Sensor	21
Auxiliary Inputs	22
Auto Zero	22
RS-232 Port 1	22
Printers	22
Computers and Modems	23
Remote Totalizer	23
mA Output 1	23
Relay Output	24
RS-485 Port 2	25
Daisy Chain	25
Terminal Device	25
RS-232 Port 3	25
Power Connections	26
mA I/O Board connections	27
Installing/replacing the back-up battery	27
Start Up	28
Keypad	28
PROGRAM Mode	29

PROGRAM Mode Display29
 To enter PROGRAM mode:29
 RUN Mode31
 Initial Start Up31
 Power Up31
 Programming31
 Press32
 Load Cell Balancing35
 Typical two load cell belt scale35
 Balancing six load cell belt scales37
 Zero Calibration38
 RUN Mode40

Recalibration41

Belt Speed Compensation41
 Material Tests42
 % Change42
 Material Test44
 Design Changes45
 Recalibration45
 Routine Zero45
 Initial Zero46
 Direct Zero47
 Auto Zero47
 Routine Span48
 Initial Span49
 Direct Span50
 Multispan50
 Online Calibration53
 Factoring58
 Linearization59

Operation63

Load Sensing63
 Speed Sensing63
 Differential Speed Detection²⁾63
 Moisture Compensation64
 Incline Compensation65
 Modes of Operation65
 Damping66
 mA I/O (0/4-20 mA)66
 Relay Output67
 Totalization68

PID Control71

Hardware71
 Connections71
 Setpoint Controller – Rate Control72
 Setpoint Controller – Load Control72
 Setpoint Controller – Master/Slave Control73

Setpoint Controller – Rate and Load Control	74
Setup and Tuning	74
Proportional Control (Gain), P	74
Integral Control (Automatic Reset), I	75
Derivative Control (Pre-Act or Rate), D	76
Feed Forward Control, F	76
PID Setup and Tuning	77
Initial Start-Up	77
Programming	80
Batching	83
Connections	84
Typical Ladder Logic	84
Programming	84
Operation	85
Pre-act Function	85
Communications	86
BW500 and BW500/L and SmartLinX®	87
Connection	87
Wiring Guidelines	87
Configuring Communication Ports	88
P770 Serial protocols	88
P771 Protocol address	89
P772 Baud Rate	89
P773 Parity	89
P774 Data bits	90
P775 Stop bits	90
P778 Modem attached	90
P779 Modem idle time	91
P780 RS-232 Transmission interval	91
P781 Data message	92
P799 Communications Control	92
Dolphin Protocol	93
Dolphin Plus Screen Shot	93
Modbus RTU/ASCII Protocol	94
How Modbus Works	94
Modbus RTU vs. ASCII	95
Modbus Format	95
Modbus Register Map	95
Modbus Register Map (cont'd)	98
Modems	107
Error Handling	109
Parameters	111
Start Up (P001 to P017)	111
Relay/Alarm Function (P100 - P117)	116
mA I/O Parameters (P200 - P220)	119
Calibration Parameters (P295 – P360)	125
Online Calibration Options (P355 to P358)	126

Linearization Parameters (P390 - P392)	129
Proportional Integral Derivative (PID) Control Parameters (P400 – P419)	130
Batch Control (P560 – P568)	134
Totalization (P619 - P648)	136
ECal Parameters (P693 – P698)	141
Communication (P740 - P799)	143
SmartLinx Hardware Testing	143
Test and Diagnostic (P900 - P951)	145
Troubleshooting	148
Generally	148
Specifically	148
Certification	151
Parameters unlocked when certification switch is set:	151
Certification Printing	152
Glossary	153
Appendix I	156
Memory Backup	156
Software Updates	156
Calibration Criteria	156
Zero	156
Span	156
PID Systems	156
Appendix II: Software Revision History	157
Index	161

Safety Notes

Special attention must be paid to warnings and notes highlighted from the rest of the text by grey boxes.



WARNING means that failure to observe the necessary precautions can result in death, serious injury, and/or considerable material damage.

Note: means important information about the product or that part of the operating manual.

The Manual

Note:

- The Milltronics BW500 and BW500/L are to be used only in the manner outlined in this instruction manual.
- These products are intended for use in industrial areas. Operation of this equipment in a residential area may cause interference to several frequency based communications.

This instruction manual covers the operation, installation, and maintenance of Milltronics BW500 and BW500/L.

Please refer to this manual for proper installation and operation of your BW500 or BW500/L belt scale integrator. As BW500 and BW500/L must be connected to a belt scale, and optionally a speed sensor, refer to their manuals as well.

The manual is designed to help you get the most out of your BW500 and BW500/L, and it provides information on the following:

- How to install the unit
- How to program the unit
- How to operate the keypad and read the display
- How to do an initial Start Up
- How to optimize and maintain accurate operation of the unit
- Outline diagrams
- Wiring diagrams
- Parameter values
- Parameter uses
- MODBUS[®] register mapping
- Modem configuration

We always welcome suggestions and comments about manual content, design, and accessibility. Please direct your comments to techpubs.smpi@siemens.com.

For the complete library of Siemens Milltronics manuals, go to www.siemens.com/weighing.

Technical Support

Support is available 24 hours a day.

To find your local Siemens Automation Office address, phone number and fax number go to:

www.siemens.com/automation/partner

- Click on the tab Contacts by Product then find your product group (+Process Automation > +Process Instrumentation > +Level Measuring Instruments).
- Select the team Technical Support. Click on Next.
- Click on the appropriate continent, then select the country followed by the city. Click on Next.

For online technical support go to:

www.siemens.com/automation/support-request

- Enter the device name (SITRANS WW100) or order number, then click on Search, and select the appropriate product type. Click on Next.
- You will be prompted to enter a keyword describing your issue. Then either browse the relevant documentation, or click on Next to email a detailed description of your issue to Siemens Technical Support staff.

Siemens A&D Technical Support Center: phone+49 180 50 50 222
fax +49 180 50 50 223

Milltronics BW500 and BW500/L

Milltronics BW500

The Milltronics BW500 is a full-featured integrator for use with belt scales and weighfeeders. The speed and load signals from the conveyor and scale, respectively, are processed to derive rate of material flow, and totalization. The primary values of speed and load, and the derived values of rate and total are available for display on the local LCD, or as output in the form of analog mA, alarm relay and remote totalization.

Milltronics BW500/L

The Milltronics BW500/L is an integrator for use in basic belt scale or weighbelt applications. The speed and load signals from the conveyor and scale, respectively, are processed to derive rate of material flow, and totalization. The BW500/L does not include the advanced feature set for control.

Milltronics BW500 and BW500/L features

BW500 and BW500/L support Siemens Milltronics Dolphin Plus software and Modbus protocol on the two RS-232 ports and the RS-485 port for communication to customer PLC or computer. BW500 and BW500/L also support Siemens SmartLinX[®] for popular industrial communication systems.

Reliable and robust user interface

- multi-field LCD display
- local keypad

Instrumentation I/O

	BW500	BW500/L
remote totalizer contacts	2	2
programmable relays	5	2
programmable discrete inputs	5	5
mA input	2 for PID ^{a)} control	
mA output	3: rate, load, speed or PID ^{a)} control	1: rate, load, speed

- a) The optional mA I/O board is required for 3 outputs: PID control, moisture, and incline compensation.

Popular Windows[®] and Industrial communications

- two RS-232 ports
- one RS-485 port

Individual port configuration for:

- Dolphin Plus
- Modbus ASCII
- Modbus RTU
- Printer
- SmartLinx® compatible

Controls and operation functions

	BW500	BW500/L
load linearization	✓	✓
auto zero	✓	✓
PID control ^{a)}	✓	
batch control	✓	
multispan operation	✓	
moisture compensation ^{a)}	✓	fixed
incline compensation ^{a)}	✓	fixed
differential speed detection	✓	

- a) The optional mA I/O board is required for 3 outputs: PID control, moisture, and incline compensation.

Specifications

Power

- 100/115/200/230 V AC $\pm 15\%$, 50/60 Hz, 31 VA
- fuse, FU1 2AG, Slo Blo, 2 A, 250 V or equivalent

Application

- compatible with Siemens belt scales or equivalent 1, 2, 4, or 6 load cell scales (1 or 2 load cell scales for BW500/L)
- compatible with LVDT equipped scales, with use of optional interface board

Accuracy

- 0.1% of full scale

Resolution

- 0.02% of full scale

Environmental

location	indoor/outdoor
altitude	2000 m max.
ambient temperature	-20 to 50 °C (-5 to 122 °F)
relative humidity	suitable for outdoor (Type 4X / NEMA 4X / IP 65 enclosure)
installation category	II
pollution degree	4

Enclosure

- Type 4X / NEMA 4X / IP65
- 285 mm W x 209 mm H x 92 mm D (11.2" W x 8.2" H x 3.6" D)
- polycarbonate

Programming

- via local keypad and/or Dolphin Plus interface

Display

- illuminated 5 x 7 dot matrix liquid crystal display with 2 lines of 40 characters each

Memory

- program and parameters stored in non-volatile FLASH ROM, upgradable via Dolphin Plus interface
- Runtime totalizers and clock settings¹⁾ stored in battery backed RAM, battery P/N PBD-2020035 or use equivalent 3V Lithium battery (BR 2335), 5 year life

Inputs

load cell	0 - 45 mV DC per load cell
speed sensor	pulse train 0 V low, 5-15 V high, 1 to 3000 Hz, or open collector switch, or relay dry contact
auto zero	dry contact from external device
mA	see optional mA I/O board ¹
auxiliary	5 discrete inputs for external contacts, each programmable for either display scrolling, totalizer 1 reset, zero, span, multispans, print, batch reset, or PID function.

Outputs

mA	<ul style="list-style-type: none"> • 1 programmable 0/4 - 20 mA, for rate, load, and speed output • optically isolated • 0.1% of 20 mA resolution • 750 Ω load max • see optional mA I/O board¹
load cell	10 V DC compensated excitation for strain gauge type, 6 cells max, BW500 has 4 independent inputs, BW500/L has 2. The maximum load, in either case, must not exceed 150 mA.
speed sensor	12 V DC, 150 mA max excitation for each speed sensor
remote totalizer 1	<ul style="list-style-type: none"> • contact closure 10 - 300 ms duration • open collector switch rated 30 V DC, 100 mA max
remote totalizer 2	<ul style="list-style-type: none"> • contact closure 10 - 300 ms duration • open collector switch rated 240 V AC/DC, 100 mA max

¹⁾ Not available with BW500/L.

relay output

- BW500
- BW500/L

5 alarm/control relays, 1 form 'A' SPST relay contact per relay, rated 5 A at 250 V AC, non-inductive
2 alarm relays

Communications

- two RS-232 ports
- one RS-485 port
- SmartLinX[®] compatible (see *Options* below)

Cable

one load cell

- non-sensing
- sensing

Belden 8404, 4 wire shielded, 20 AWG or equivalent, 150 m (500 ft.) max.

Belden 9260, 6 wire shielded, 20 AWG or equivalent, 300 m (1000 ft.) max.

two/four/six¹⁾ load cells

- non-sensing
- sensing

Belden 9260, 6 wire shielded, 20 AWG or equivalent, 150 m (500 ft.) max.

Belden 8418, 8 wire shielded, 20 AWG or equivalent, 300 m (1000 ft.) max.

speed sensor

Belden 8770, 3 wire shielded, 18 AWG or equivalent, 300m (1000 ft.)

auto zero

Belden 8760, 1 pair, twisted/shielded, 18 AWG, 300 m (1000 ft.) max.

remote total

Belden 8760, 1 pair, twisted/shielded, 18 AWG, 300 m (1000 ft.) max.

Options

Speed Sensor

Siemens MD-36/36A/256 or 2000A, RBSS, TASS, WS100, or WS300, or compatible

Dolphin Plus

Siemens Windows[®] based software interface (refer to associated product documentation)

SmartLinX[®] Modules

protocol specific modules for interface with popular industrial communications systems (refer to associated product documentation)

¹⁾ For four or six load cell scales, run two separate cables of the two load cell configuration. Four/six load cells not available with BW500/L.

mA I/O board¹⁾

- inputs

- 2 programmable 0/4 – 20 mA for PID, control, incline, and moisture compensation, and online calibration
- optically isolated
- 0.1% of 20 mA resolution
- 200 Ω input impedance

- outputs

- 2 programmable 0/4 – 20 mA for PID control, rate, load, and speed output
- optically isolated
- 0.1% of 20 mA resolution
- 750 Ω load max

- output supply

isolated 24 V DC at 50 mA, short circuit protected

LVDT interface card

for interface with LVDT based scales

Weight

- 2.6 kg (5.7 lb.)

Approvals

	BW500	BW500/L
CE ^{a)} , CSA US/C, C-TICK, GOST	✓	✓
Legal for Canadian Trade - Measurement Canada approved	✓	
Legal for US Trade - NTEP approved	✓	
Legal for European Trade - MID approved	✓	
Legal for International Trade - OIML approved	✓	

a) EMC performance available upon request

¹⁾ Not available with BW500/L.

Installation

Note:

- Installation shall only be performed by qualified personnel and in accordance with local governing regulations.
- This product is susceptible to electrostatic shock. Follow proper grounding procedures.

Dimensions

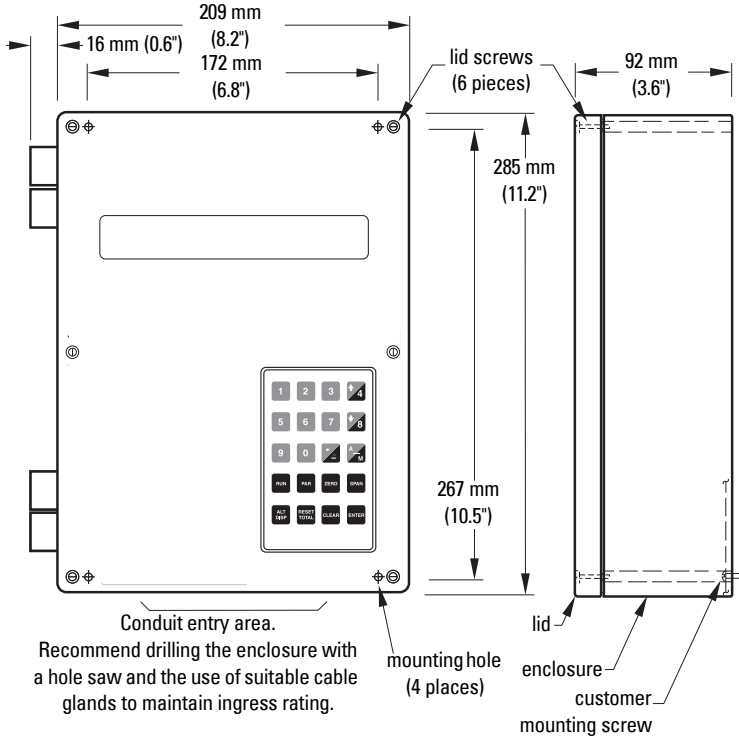

Note: Non metallic enclosure does not provide grounding between connections. Use grounding type bushings and jumpers.

Mounting the Enclosure

1. Remove the lid screws and open the lid to reveal the mounting holes.

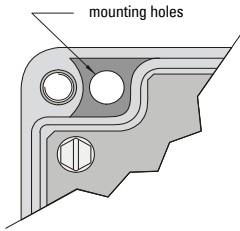

unit.

2. Mark and drill four holes in the mounting surface for the four screws (customer supplied).
3. Fasten with a long screwdriver.

Please note:

- Recommended mounting: directly to wall or to electrical cabinet back panel
- Recommended mounting screws: #6
- If alternate mounting surface is used, it **MUST** be able to support four times the weight of the

Layout

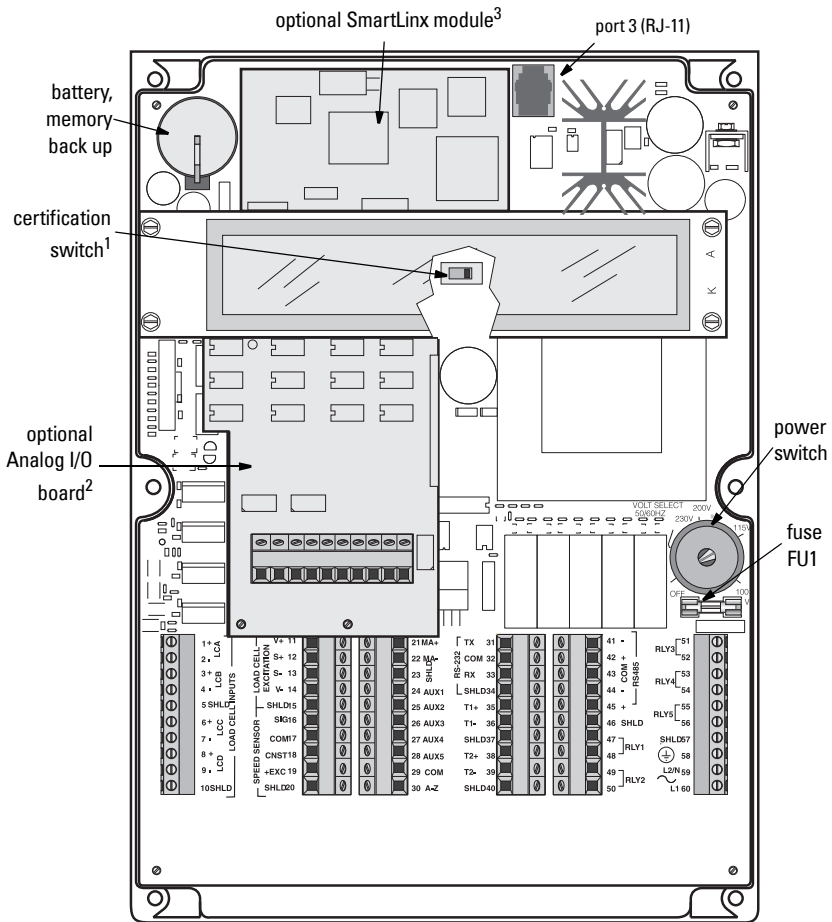

1. Applicable for trade approvals
2. Not available for BW500/L
3. To reduce communication interference, route SmartLinx® cable along right side of enclosure wall.

WARNING:



- All field wiring must have insulation suitable for at least 250 V.
- DC terminals shall be supplied from SELV source in accordance with IEC 10101-1 Annex H.
- Relay contact terminals are for use with equipment having no accessible live parts and wiring having insulation suitable for at least 250 V.
- The maximum allowable working voltage between adjacent relay contact shall be 250 V.

Optional Plug-ins

SmartLinx® Module

BW500 and BW500/L is software/hardware ready to accept the optional Siemens SmartLinx® communications module that provides an interface to one of several popular industrial communications systems.

BW500 and BW500/L may be shipped to you without a SmartLinx® module, for installation at a later date.

If you are ready to install your SmartLinx® module, or want to change it, please follow the instructions as outlined.

Installation

1. Isolate power and voltages applied to the BW500 and BW500/L
2. Open the lid
3. Install the module by mating the connectors and secure in place using the two screws provided
4. Route communication cable to SmartLinx® module along the right side of the enclosure wall. This route will reduce communication

Note: Refer to the SmartLinx® documentation for any required hardware settings prior to closing the lid.

5. Close the lid.
6. Apply power and voltage to the BW500 and BW500/L.

Refer to:

- SmartLinx® Module in the *Specifications* section on page 5
- *P750 – P769 SmartLinx® Module Specific Parameters* on page 143 in this manual
- the SmartLinx® manual for wiring

mA I/O board¹⁾

BW500 is software/hardware ready to accept the optional mA I/O board. The mA I/O board provides 2 programmable 0/4-20 mA outputs, 2 programmable 0/4-20 mA inputs and a nominal 24 V DC supply for loop powered devices.

BW500 may be shipped to you without an mA I/O board, for installation at a later date.

If you are ready to install your mA I/O board, please follow the instructions as outlined.

¹⁾ Not available with the BW500/L

Installation

1. Isolate power and voltages applied to the BW500
2. Open the lid
3. Install the board by mating the connectors and secure the card in place using the three screws provided
4. Close the lid
5. Apply power and voltage to the BW500

Refer to:

- *Specifications* on page 8
- *mA I/O board connections* on page 27
- *mA I/O Parameters (P200 - P220)* on page 119
- *mA I/O (0/4-20 mA)* in the *Operation* section on page 66

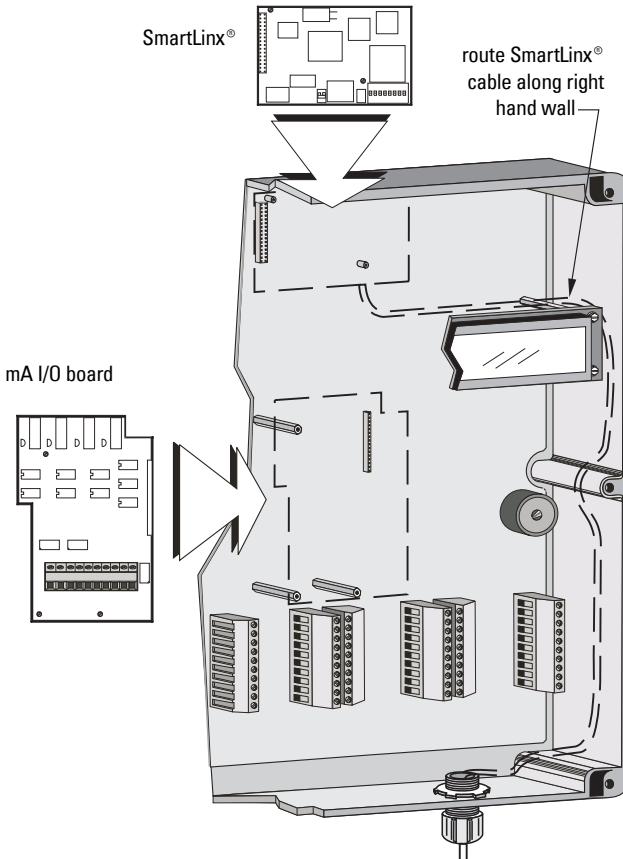

Interconnection

Note:

- Wiring may be run via common conduit. However, these may not be run in the same conduit as high voltage contact or power wiring.
- Ground shield at one point only.
- Insulate at junctions to prevent inadvertent grounding.

System Diagram

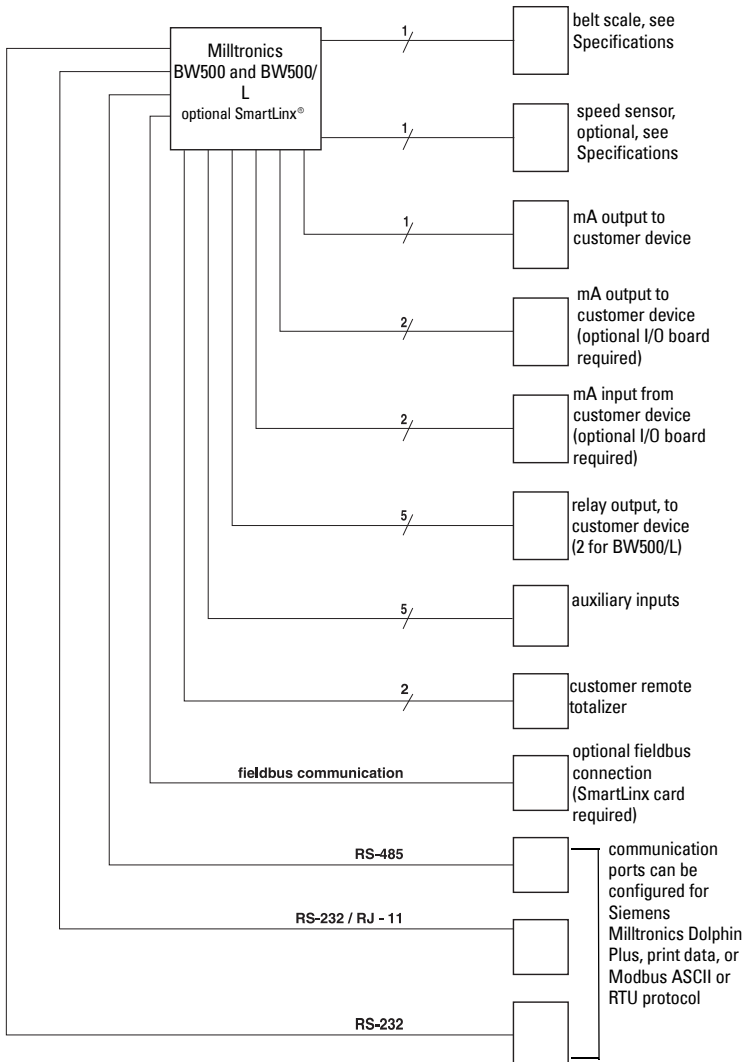

Note: Typical system capability. Not all components or their maximum quantity may be required.

Scale – One Load Cell

**Siemens
Belt Scale**

Note: Colour code for load cells used on Siemens weighfeeders may be different than shown. Please refer to the weighfeeder wiring diagram.

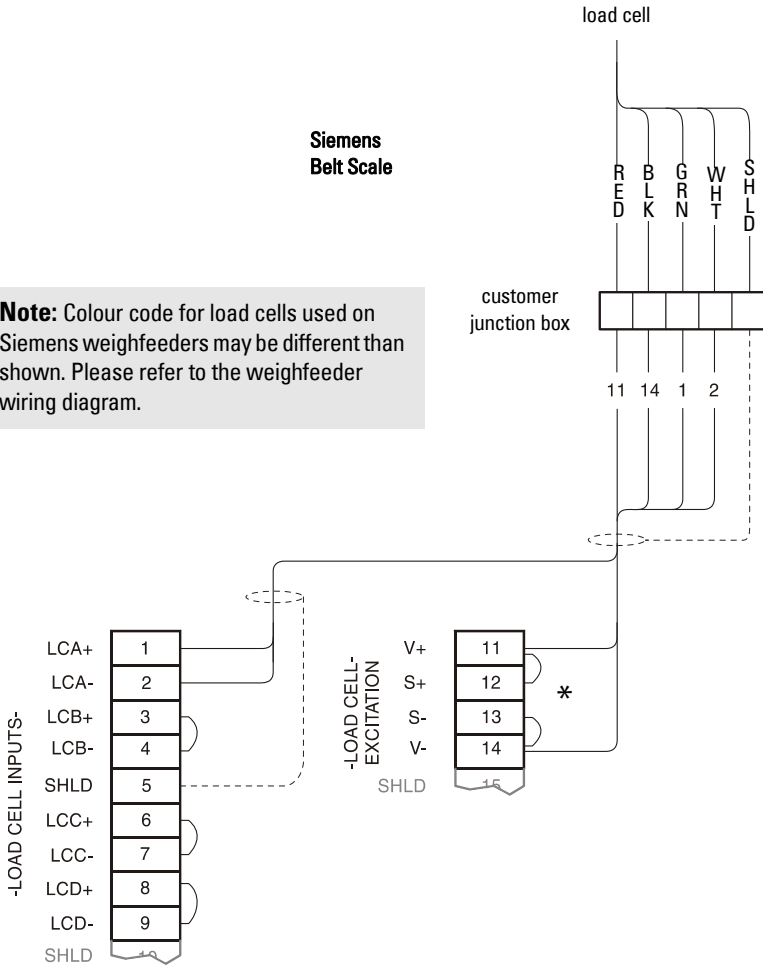

*Where separation between the BW500 and BW500/L and belt scale exceeds 150 m (500 ft.), or legal for trade certification:

1. remove jumpers from BW500 and BW500/L terminal 11/12 and 13/14
2. run additional conductors from:
 BW500 and BW500/L terminal 12 to scale `red`
 BW500 and BW500/L terminal 13 to scale `blk`

If the load cell wiring colours vary from those shown, or if extra wires are provided, consult Siemens.

Scale – Two Load Cells

Siemens Belt Scale

Note: Colour code for load cells used on Siemens weighfeeders may be different than shown. Please refer to the weighfeeder wiring diagram.

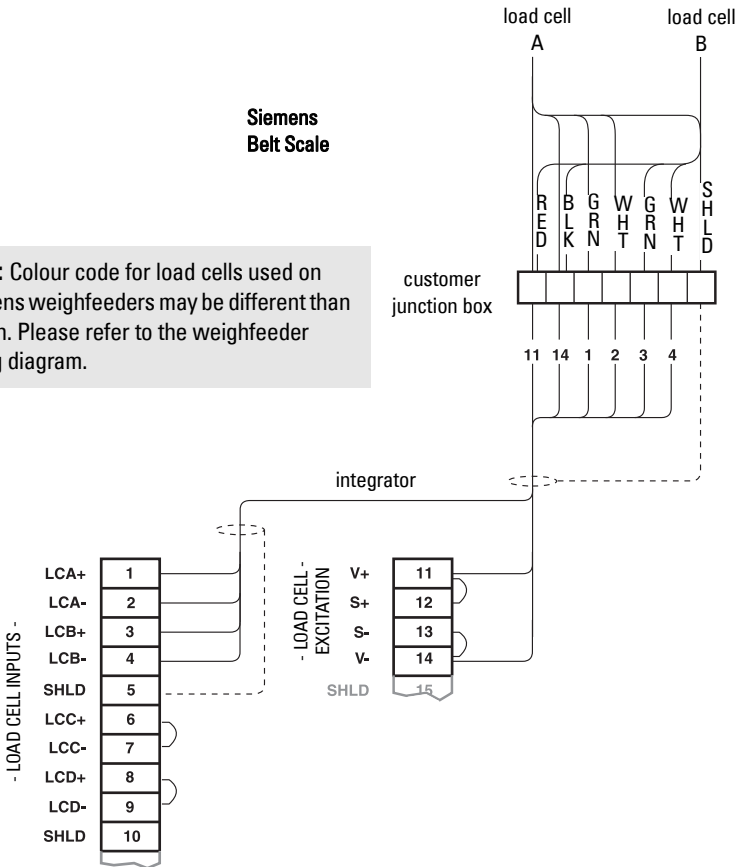

Where separation between the BW500 and BW500/L and belt scale exceeds 150 m (500 ft.), or legal for trade certification:

1. remove jumpers from BW500 and BW500/L terminal 11/12 and 13/14
2. run additional conductors from:
 BW500 and BW500/L terminal 12 to scale `red'
 BW500 and BW500/L terminal 13 to scale `blk'

If the load cell wiring colours vary from those shown, or if extra wires are provided, consult Siemens.

Scale – Four Load Cells¹⁾

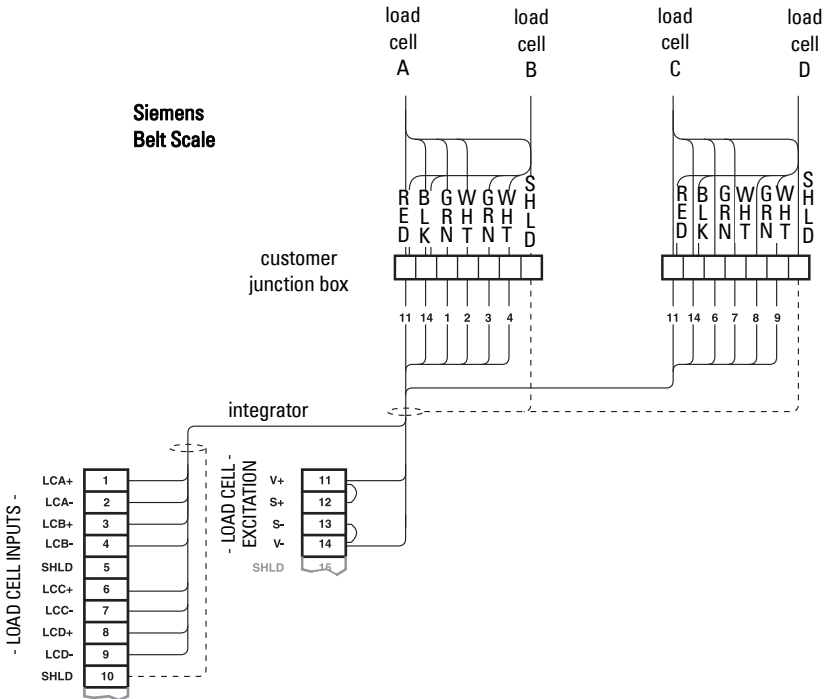

Where separation between the BW500 and belt scale exceeds 150 m (500 ft.), or legal for trade certification:

1. remove jumpers from BW500 terminal 11/12 and 13/14
2. run additional conductors from:
 BW500 terminal 12 to scale `red`
 BW500 terminal 13 to scale `blk`

If the load cell wiring colours vary from those shown, or if extra wires are provided, consult Siemens.

¹⁾ Not available with the BW500/L

Scale – Six Load Cells¹⁾

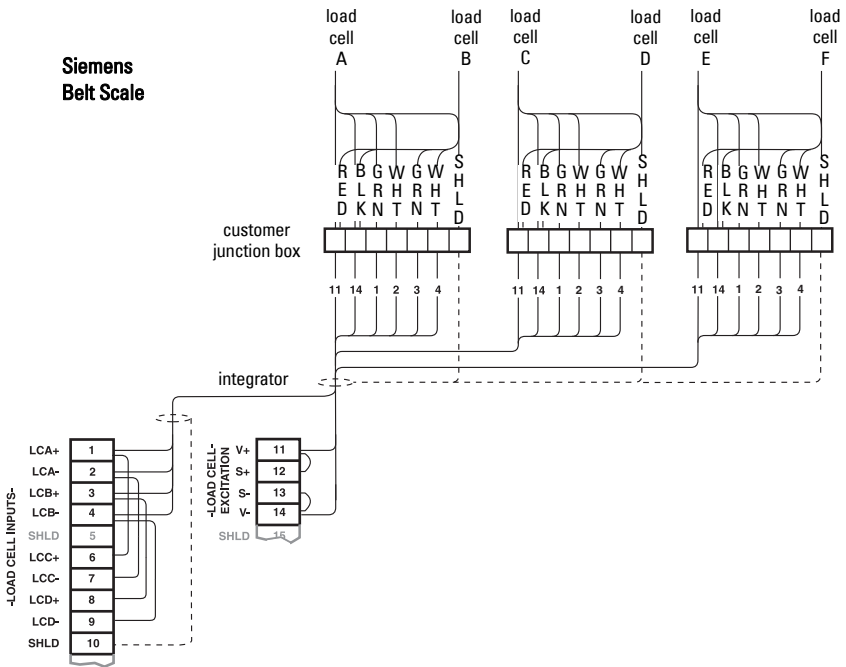

Where separation between the BW500 and belt scale exceeds 150 m (500 ft.), or legal for trade certification:

1. remove jumpers from BW500 terminal 11/12 and 13/14
2. run additional conductors from:
 BW500 terminal 12 to scale `red`
 BW500 terminal 13 to scale `blk`

If the load cell wiring colours vary from those shown, or if extra wires are provided, consult Siemens.

¹⁾ Not applicable for the BW500/L.

Scale – LVDT

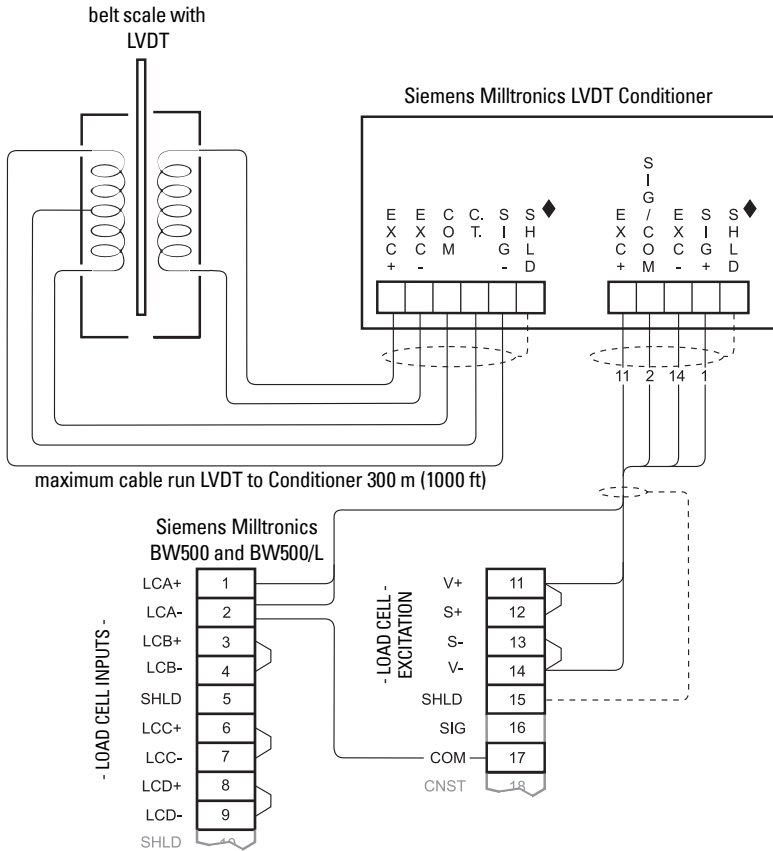

Where separation between the BW500 and BW500/L and LVDT conditioner exceeds 150 m (500 ft):

1. remove jumpers from BW500 and BW500/L terminal 11/12 and 13/14
2. run additional conductors from:
 BW500 terminal 12 to integrator terminal block '+EXC'
 BW500 terminal 13 to integrator terminal block '-EXC'

For further connection information on specific LVDTs consult Siemens.

Speed

Constant Speed (No Sensor)

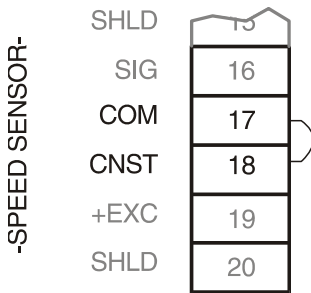

If a speed sensor is not used, a jumper or contact closure must be connected across BW500 and BW500/L terminals 17 / 18 when the conveyor is running. If a speed sensor is used, ensure that the jumper is removed.

Note: With contact closed or jumpered when the conveyor is idle, the integrator will continue totalizing.

Main Speed Sensor

WS300 Example

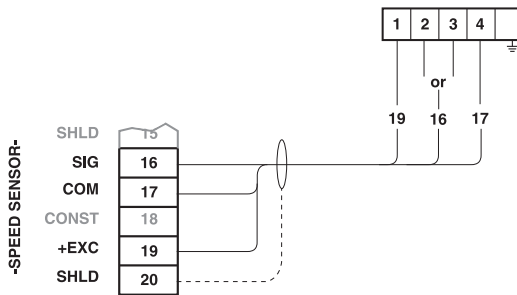

Note: Shields are common, but not grounded to chassis. Run cable shields through SHLD terminals and ground at BW500 and BW500/L only.

Connect BW500 and BW500/L terminal 16 to speed sensor terminal:

- '2' for clockwise speed sensor shaft rotation
- '3' for counter-clockwise speed sensor shaft rotation.

Speed sensor shaft rotation is viewed from the front cover of the speed sensor enclosure.

Input device in the form of open collector transistor or dry contact across BW500 and BW500/L terminals 16 / 17 will also serve as a suitable speed signal.

If a speed sensor other than the models shown is supplied, consult with Siemens for details.

A second speed sensor input can be added using the Auxiliary inputs: the second speed input allows calculation of Differential Speed. For more information, see *Auxiliary Inputs (P270)* on page 122.

Auxiliary Speed Sensor¹⁾

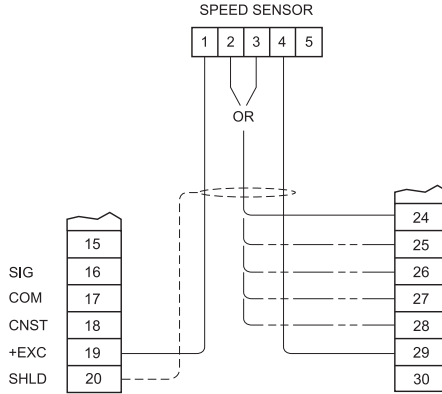

Note: Shields are common, but not grounded to chassis. Run cable shields through SHLD terminals and ground at BW500 only.

Connect BW500 terminal 24-28 to speed sensor terminal:

- '2' for clockwise speed sensor shaft rotation
- '3' for counter-clockwise speed sensor shaft rotation.

Speed sensor shaft rotation is viewed from the front cover of the speed sensor enclosure.

Input device in the form of open collector transistor or dry contact across BW500 terminals 24-28 will also serve as a suitable speed signal.

If a speed sensor other than the models shown is supplied, consult with Siemens.

¹⁾ Not available for BW500/L.

Auxiliary Inputs

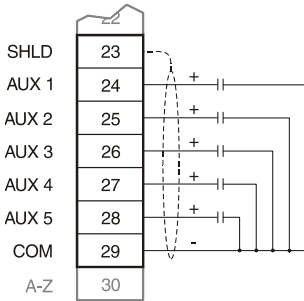

Customer dry contacts, or open collector transistor output supplied as required

Refer to *P270* on page 122 for programming details.

Auto Zero

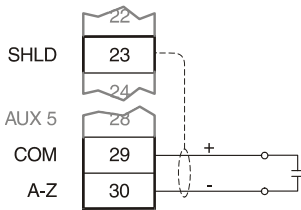

Prefeed activated dry contact

Refer to *Auto Zero* on page 47.

RS-232 Port 1

Printers

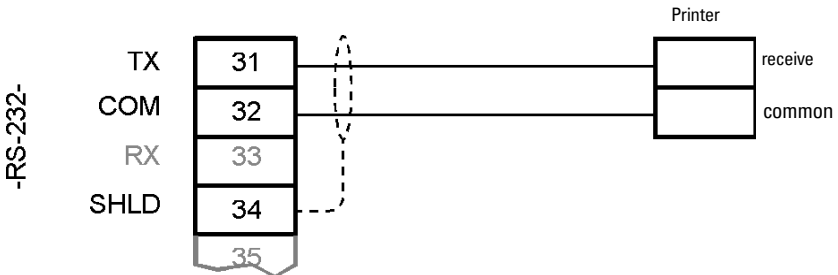

Computers and Modems

For connection to a PC compatible computer or modem, using no flow control, typical configurations are:

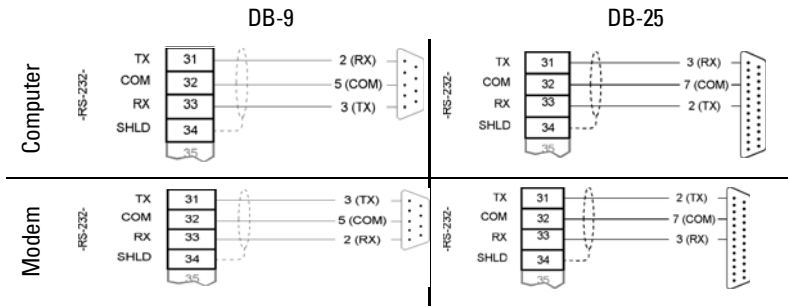

Remote Totalizer

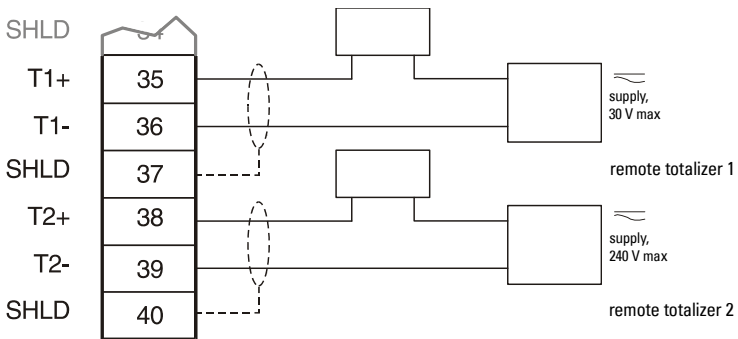

Note: External power supply not required on all totalizer models.

mA Output 1

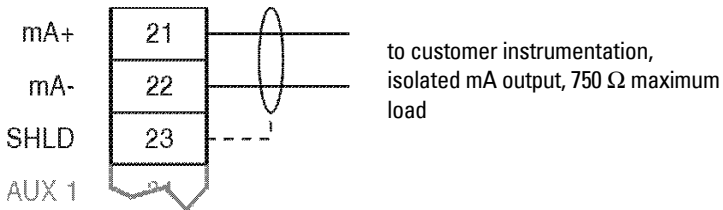

Relay Output¹⁾

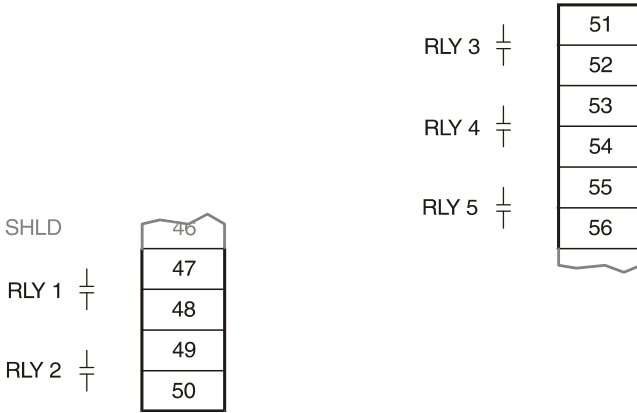

Relays shown in de-energized state, contacts normally open, rated 5 A at 250 V non-inductive.

¹⁾ BW500/L has relay 1 and 2 only

Power Connections

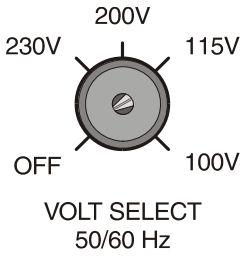

Note:

1. The equipment must be protected by a 15 A fuse or a circuit breaker in the building installation.
2. A circuit breaker or switch in the building installation, marked as the disconnect switch, shall be in close proximity to the equipment and within easy reach of the operator

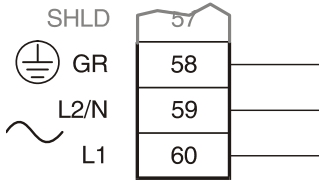

100 / 115 / 200 / 230 V
50 / 60 Hz
select voltage via switch

mA I/O Board connections¹⁾

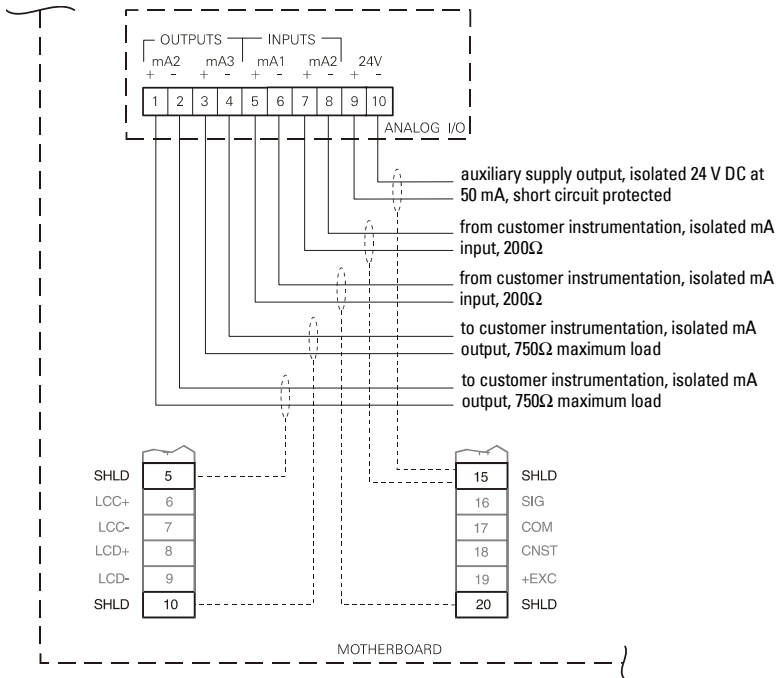

Installing/replacing the back-up battery

The battery (see Specifications, page 5) should be replaced every 5 years to ensure back up during lengthy power outages. An on board capacitor provides 20 minutes of charge to preserve the memory while the battery is being changed.

Note:

- Do not install the memory backup battery until the BW500 and BW500/L is installed, as it begins operation immediately.
- The unit is supplied with one battery (battery P/N PBD-2020035 (BR 2335) or use equivalent 3V Lithium battery). Insert the battery into the holder as shown in the following diagram before using the BW500 and BW500/L.



Disconnect power before installing or replacing the battery.

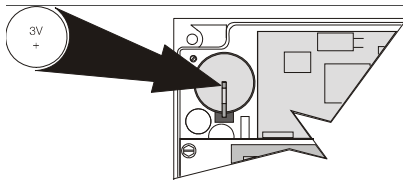

Installation Steps

1. Open the enclosure lid.
2. Slide the battery into the holder. Be sure to align the + and – terminals correctly.
3. Close and secure enclosure lid.

¹⁾ Not available with BW500/L.













Start Up

Note: For successful start up, ensure that all related system components, such as the belt scale and speed sensor, are properly installed and connected.

BW500 and BW500/L operates under two modes: **RUN** and **PROGRAM**. On initial power-up, the unit starts in the **PROGRAM** mode.

Keypad



Key	Function	
	PROGRAM mode	RUN mode
 	In view mode: scrolls through parameter list	changes PID local setpoint values
	decimal key	prints
	minus key	switches PID between auto and manual mode
	opens RUN mode	
	opens parameter direct entry	opens PROGRAM mode
 	initiates calibration	initiates calibration
	clears entry	
	toggles between view and edit modes, confirms parameter values	
	opens RUN mode	changes RUN mode display
		starts totalizer 1 reset sequence

PROGRAM Mode

The **PROGRAM** parameters define the calibration and operation of the BW500 and BW500/L.

In **PROGRAM** mode, the user can view the parameter values or edit them to suit the application.

PROGRAM Mode Display

VIEW

P001 Language	V
1-Eng 2-Fra 3-Deu 4-Esp	1

EDIT

P001 Language	E
1-Eng 2-Fra 3-Deu 4-Esp	1

To enter PROGRAM mode:

Press 

P001 Language	V
1-Eng 2-Fra 3-Deu 4-Esp	1

The default of previous parameter view is displayed

e.g. P001 is the default parameter for initial start up

To select a parameter:

Press  to move up,

P002 Test Reference Selection	V
1-Weight, 2-Chain, 3-Ecal	1

e.g. scrolls up from P001 to P002

Press  to move down.

P001 Language	V
1-Eng 2-FR 3-DEU 4-ESP	1

e.g. scrolls up from P002 to P001

To access a parameter directly:

Press 

View/Edit Parameter
Enter Parameter Number

Press **0** **1** **1** **ENTER** in sequence.

P011 Design Rate:	V
Enter Rate	100.00 kg/h

e.g. access P011, design rate

Or press **9** **↑** **4** **0** **A** **2** **ENTER** For direct access to index parameters

P940-2 Load Cell mV Signal Test	V
mV reading for B	6.78

e.g. access P940-2, load cell B mV signal

To change a parameter value

P011 Design Rate:	V
Enter Rate	100.00 kg/h

from the view mode

Press **ENTER**

P011 Design Rate:	E
Enter Rate	100.00 kg/h

If edit mode is not enabled after pressing ENTER, security is locked. Refer to *Security Lock (P000)* on page 111 for instructions on disabling

Press **2** **0** **0** **ENTER** Enter the new value

P014 Design Speed	V
Enter Speed	0.08 m/S

For P001 to P017, ENTER effects the change and scrolls to the next required parameter.

To reset a parameter value

Press **ENTER**

P011 Design Rate:	E
Enter Rate	100.00 kg/h

From the edit mode

Press **CLEAR** **ENTER**

P011 Design Rate:	V
Enter Rate	0.00 kg/h

Value is reset to factory value.
e.g. 0.00 kg/h

RUN Mode

To operate BW500 and BW500/L in the **RUN** mode, the unit must undergo an initial programming to set up the base operating parameters.

Attempting to enter the **RUN** mode without satisfying the program requirements forces the program routine to the first missing item.

Initial Start Up

Initial start up of BW500 and BW500/L consists of several stages, and assumes that the physical and electrical installation of the belt scale and speed sensor, if used, is complete:

- power up
- programming
- load cell balancing
- zero and span calibration

Power Up

Upon initial power up, BW500 and BW500/L displays:

P001 Language	V
1-Eng 2-Fra 3-Deu 4-Esp	1

The initial display prompts the user to select the preferred language.

Programming

Press 

BW500 and BW500/L then scrolls sequentially through the start up program as parameters P001 through P017 are addressed.

P002 Test Reference Selection	V
Select 1-Weight, 2-Chain, 3-Ecal	1

e.g. Accept 'weight' (supplied with scale) as the test reference.

Press 

P003 Number of Load Cells	V
Enter Number of Load Cells	2

e.g. Accept '2' as the number of load cells.

Press

P004 Rate Measurement System	V
Select 1-Imperial, 2-Metric	2

e.g. Accept '2' for measurements in metric.

Press

P005 Design Rate Units:	V
Select: 1-t/h, 2-kg/h, 3-kg/min	1

e.g. Accept '1' for units in t/h

Note: t/h equals metric tonnes per hour

Press 1)

P008 Date:	V
Enter YYYY-MM-DD	1999-03-19

default date

Press

P008 Date:	E
Enter YYYY-MM-DD	1999-03-19

e.g. enter current date of March 19, 1999

Press

P009 Time:	V
Enter HH-MM-SS	00-00-00

factory set time 24 hour clock

Press

P009 Time:	E
Enter HH-MM-SS	00-00-00

e.g. enter current time of 14:41

Press

P011 Design Rate:	V
Enter Rate	0.00 t/h

factory design rate

Press

P011 Design Rate:	E
Enter Rate	0.00 t/h

e.g. rate of 100 t/h

1) Not applicable for the BW500/L

Press **1** **0** **0** **ENTER**

P014 Design Speed	V	factory design speed
Enter Speed	0.00 m/s	

Press **ENTER**

P014 Design Speed	E	e.g. speed of 0.8 m/s
Enter Speed	0.00 m/s	

Press   **8** **ENTER**

P015-01 Speed Constant	V
Pulses/m	0.0000

If the speed input is configured for constant speed, display value reads 'Jumpered'

press  **4** to advance.

If the speed input is connected to a speed sensor, pressing enter at P015 invokes P690 for data entry.

Press **ENTER**

P690-01 Speed Constant Entry	E
1-Calculated, 2-Sensor Data	1

Select: 1 - Calculated

The program returns to P015. Calculate the value per Parameter P690.

Press **ENTER**

P015-01 Speed Constant	E
Pulses/m	0.0000

Select: 2 - Sensor Data

The program advances through parameters P691 and P692 prompting entry from the sensor name-plate. From this data, the speed constant is calculated and automatically entered into P015.

P691-01 Step 1: Drive Pulley Diameter	V
	0.00 mm

Press

1 **0** **0**  **3** **ENTER**

e.g. speed constant of 100.3 pulses per meter

P692-01 Step 2: Pulses per sensor Rev.	V
Enter Pulses	0.00

P015-01 Speed Constant	V
Pulses/m	0.0000

This value is calculated. For manual or automatic calculation, refer to *P690* on page 140. To program Differential Speed (P015-02), follow steps above for P015-01.

P016 Belt Length	V	factory set length
Enter Length	0.000 m	

Press 

P016 Belt Length	E
Enter Length	0.000 m

e.g. belt length of 25 m

Press   

P017 Test Load: Weight MS 1	V
Enter test load	0.00 kg/m

If P002 Test Load Reference had been set for 2-Chain, the display would read:

P017 Test Load: Chain MS 1	V
Enter test load	0.00 kg/m

or, if 3-ECal refer to ECal parameters (P693 - P699 on page 141)

P017 Test Load: ECal MS 1	V
Enter test load	0.00 kg/m

or, if P002 is set to 1-Weight, pressing enter at P017 invokes P680 for data entry.

Press 

P680 Test Load: Weight MS 1	V
1-Enter Value, 2-Enter Data	0

Select: 1 - Enter Value

The program returns to P017.

Press 

P017 Test Load: Weight MS 1	E
Enter test load	00.00

Press

e.g. test load of 20.5 kg/m

Select: 2 - Enter Data

The program advances through parameters P681 and P682 prompting entry of the total mass of all the test weights used for SPAN calibration and the average measured idler space before and after the scale. From this data the test load is calculated and automatically entered into P017

P681 Step 1: Total Mass of Test Weights	V
	0.00 kg

Units are selected in P004: metric, imperial.

P682 Step 2: Average Idler Space	V
	0.00 m

P017 Test Load: Weight MS 1	V
Enter test load	00.00

This value is calculated. For manual or automatic calculation, refer to P680 on page 139. The test load value should be less than the design load (P952). If not, contact Siemens.

The initial programming requirements are now satisfied. To ensure proper entry of all critical parameter values, return to P002 and review parameters through to P017.

Load Cell Balancing

Note: Load cell balancing is not required if the selected test reference is ECal (P002 = 3). In the case of ECal, the load cells are balanced by the ECal procedure. Note that ECal cannot be used on a six load cell belt scale.

If you are operating a two or four load cell belt scale, it is recommended that the load cells be balanced electronically prior to initial programming and calibration, or after either or both load cells have been reinstalled or replaced.

Unbalanced load cells can adversely affect the performance of your belt conveyor weighing system.

With the conveyor stopped and locked out, lift the belt off the weighing idlers.

Typical two load cell belt scale

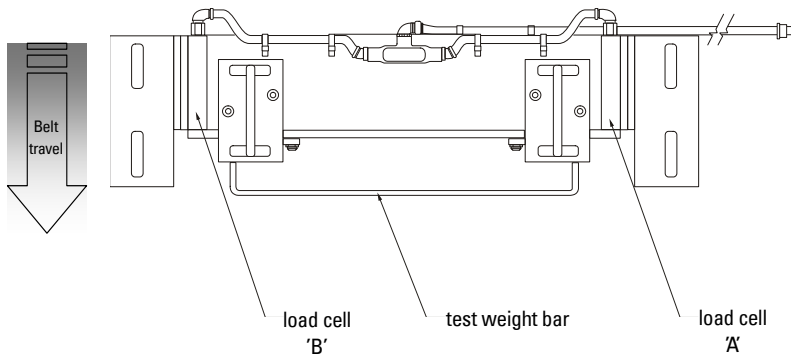

Access P295

P295 Load Cell Balancing:	E
Select: 1-A&B, 2-C&D	0

option '2' enabled only if P003, number of load cells is 4

Press **1** **ENTER**

Load Cell Balancing A & B
Place weight at cell B and press ENTER

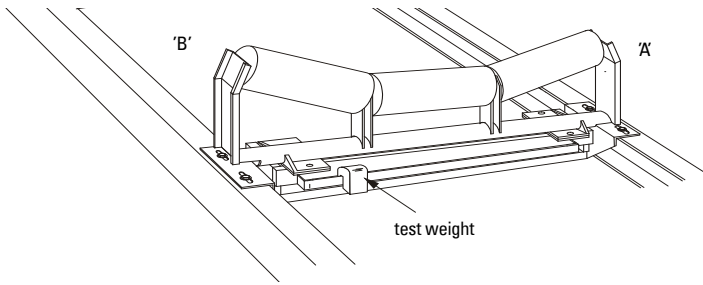

Press **ENTER**

Load Cell Balancing A & B
Place weight at cell A and press ENTER

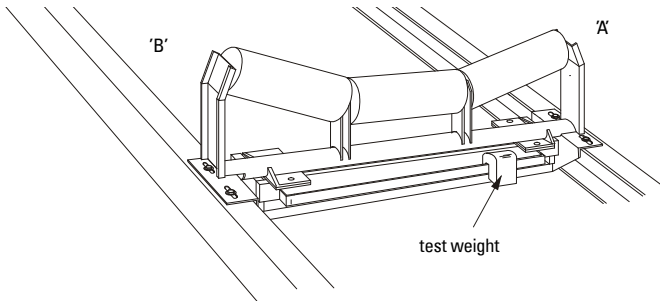

Press **ENTER**

Load Cell Balancing A & B
Load cells are now balanced.

Balancing the load cells requires a subsequent zero and span calibration

if four load cell scale, press **ENTER** to continue

P295 Load Cell Balancing: V
Select: 1-A&B, 2-C&D 1

Press **ENTER**

P295 Load Cell Balancing: E
Select: 1-A&B, 2-C&D 1

Press **2** **ENTER**

Load Cell Balancing C & D
Place weight at cell D and press ENTER.

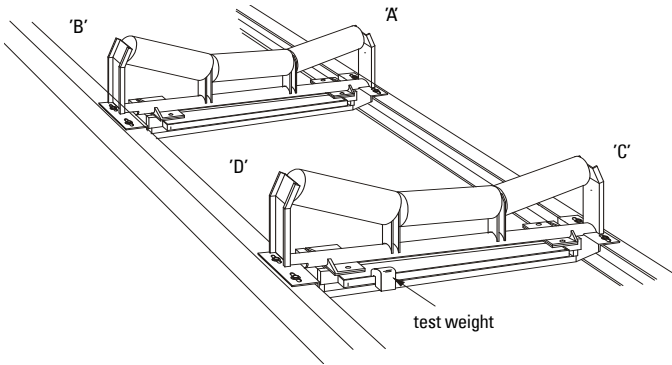

Press 

Load Cell Balancing C & D
Place weight at cell C and press ENTER.

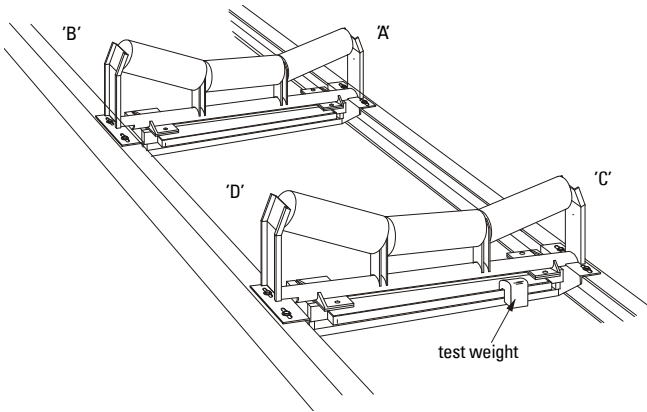

Press 

Load Cell Balancing C & D
Load cells are now balanced.

Balancing the load cells requires a subsequent zero and span recalibration

Balancing six load cell belt scales

For a six load cell belt scale, the six load cells are connected into four inputs. Load cells A, C and E are connected into inputs A and C; load cells B, D and F are connected into inputs B and D.

Balancing load cells is still recommended to optimize system accuracy. The balancing needs to be done twice, once for P295-01 = A and B and then once for P295-02 = C and D.

Three weights that are all very close to the same mass are required.

Balancing for A and B

1. Place one weight at load cell B, one weight at load cell D and one weight at load cell F, all at the same time.
2. Start the balancing procedure for A and B.
3. Press enter for B.
4. Move the 3 weights to A, C and E.
5. Press enter for A.

Balance for A side and B side is complete.

Balancing for C and D

1. Move all the weights back to B, D and F.
2. Set P295 to C and D.
3. Press enter for D (or B, depending on software revision).
4. Move the 3 weights again to A, C and E.
5. Press enter for C (or A, depending on software revision).

Balance for C and D is complete. Remove the weights and perform zero calibrations.

Zero Calibration

Note: To obtain an accurate and successful calibration, ensure that the required criteria are met. Refer to *Calibration Criteria* on page 156.

Press 

Zero Calibration: Current Zero	0	the current zero count
Clear belt. Press ENTER to Start		

Press 

Initial Zero Calibration. In progress	%	the zero count being calculated while calibration is in progress
Current Reading:	#####	

The duration of the Zero calibration is dependent on speed (P014), length (P016), and revolutions (P360) of the belt.

Calibration Complete. Deviation	0.00	the deviation from previous zero. For an initial zero there is no previous zero; hence the deviation is 0.
Press ENTER to accept value:	551205	

Press 

Zero Calibration. Current Zero	551205
Clear belt. Press ENTER to Start	

Accepting the Zero returns to start of Zero. A new Zero can be performed, or continue to Span.

Note: The moisture meter is ignored during calibration. If inclinometer is used, then calibration is adjusted based on incline angle.

Span Calibration

When performing a Span Calibration where the test reference is ECal (P002 = 3), the supplied test weight or test chain must not be applied, and the conveyor must be run empty.

Note: To obtain an accurate and successful calibration, ensure that the required criteria are met. Refer to *Calibration Criteria* on page 156.

With the conveyor stopped and locked out, apply the test weight or chain to the scale as instructed in the associate manuals; then start the conveyor.

Press 

Span Calibration Current Span	0	the current span count
Setup test Press ENTER to Start		

Press 

Initial Span Calibration in progress	%	the span count being calculated while cali-
Current Reading	####	bration is in progress

The duration of the Span calibration is dependent on speed (P014), length (P016), and revolutions (P360) of the belt.

if

Span Count Too Low	signal from load cell too low, ensure proper test weight or chain is applied during calibration
Press CLEAR to continue	

check for proper load cell wiring and ensure shipping brackets have been removed.

the deviation from the previous span.
For an initial span, there is no previous span count; hence the deviation is 0.

Calibration Complete Deviation	0.00
Press ENTER to accept value:	36790

e.g. the new span count, if accepted.

Press 

Span Calibration. Current Span 36790
Setup test. Press ENTER to Start

e.g. the current span count

Accepting the Span returns to start of Span. A new Span can be performed, or enter **RUN** mode. If calibrating with a test weight or test chain, remove it from the scale and store in a secure place before returning to **RUN** mode.

Note: The moisture meter is ignored during calibration. If the Inclinator is used, then calibration is adjusted based on incline angle.

RUN Mode

Proper programming and successful zero and span calibration allow entry into the **RUN** mode. Otherwise, entry is denied and the first missing item of programming or calibration is displayed.

Press 

Rate 0.00 t/h
Total 1 0.00 t

e.g. if there is no material on the belt and the conveyor is running. The current rate is 0 and no material has been totalized.

Once the initial programming is complete and the BW500 and BW500/L is operating in the **RUN** mode, you may now put the belt conveyor into normal service. The BW500 is functioning under its initial program and calibration, reporting rate of material flow and totalizing.

Recalibration

Belt Speed Compensation

To achieve optimum accuracy in the rate computation, the belt speed displayed must equal that of the actual belt speed. As the speeds are likely to differ, a belt speed compensation should be performed.

Run the conveyor with the belt empty.

View the belt speed.

Access P018

P018 Speed Adjust	V	e.g. current speed of 0.6 m/s
Enter New Speed	0.60	

Stop the conveyor and measure a length of the belt; marking the forward end (start time) and the back end (stop time). Use the belt scale as the stationary reference.

Run the belt and measure the time for the belt length to pass over the scale.

$$\text{speed} = \frac{\text{belt length}}{\text{time}} \text{ m/s or ft/min.}$$

Refer to the *Start Up* section on page 28 for instructions on parameter selection and changing values.

Press 

P018 Speed Adjust	E	e.g. current speed of 0.6 m/s
Enter New Speed	0.60	e.g. enter correct speed of 0.63 m/s

Press     

P015 Speed Constant	V	speed sensor constant, adjust for P015
Pulses/m	97.5169	

if

P014 Design Speed	V	for constant speed (jumper), adjusts P014
Enter Speed	0.63 m/s	

The displayed speed (used in the rate computation) now equals the actual speed.

Note: When the speed adjust is entered, the instantaneous speed of the BW500 at that time is used; this may cause an additional error if the speed is not checked again compared to the BW500. Continue checking the speed against the BW500 and adjusting until the speed can be matched exactly to when the input is entered.

Material Tests

Perform material tests to verify the accuracy of the span calibration and compensate for material flow. If the material tests indicate a repeatable deviation exists, perform a manual span adjust (P019). This procedure automatically alters the span calibration and adjusts the test load (P017) value, yielding more accurate span recalibrations.

If the span adjust value is within the accuracy requirements of the weighing system, the material test was successful. Resume normal operation.

If the span adjust value is not acceptable, repeat the material test to verify repeatability. If the result of the second material test differs considerably, consult Siemens or contact your local Siemens representative.

If the span adjust values are significant and repeatable, perform a manual span adjust.

Note: Test weights are NOT used during material tests.

There are two methods of executing the manual span adjust: *% Change* and *Material Test*

- *% Change:* based on the material test, the difference between the actual weight of material and the weight reported by the BW500 and BW500/L is calculated and entered into P019 as % change.
- *Material Test:* based on material test, the actual weight of material is entered into P019

The method of execution is a matter of preference or convenience, and either way yields the same result.

% Change

To run a %Change material test:

1. Run the belt empty
2. Perform a zero calibration
3. Put the BW500 and BW500/L into **RUN** mode
4. Record the BW500 and BW500/L total as the start value _____
5. Run material at a minimum of 50% of design rate over the belt scale for a minimum of 5 minutes
6. Stop the material feed and run the conveyor empty
7. Record the BW500 and BW500/L total as the stop value _____
8. Subtract the start value from the stop value to determine the BW500 and BW500/L total
9. Weigh the material sample if not already known

BW500 and BW500/L total = _____

material sample weight = _____

Calculate the span adjust value:

$$\% \text{ span adjust} = \frac{(\text{BW500} - \text{material sample weight}) \times 100}{\text{material sample weight}}$$

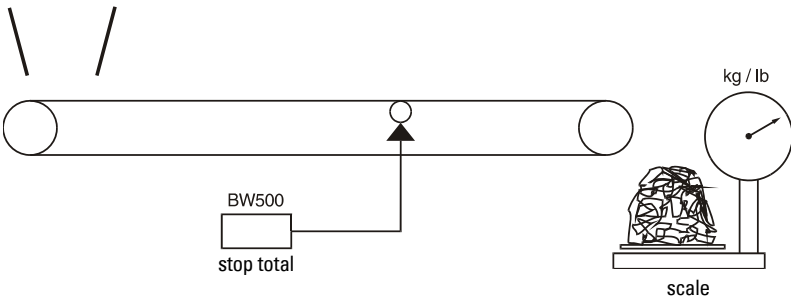
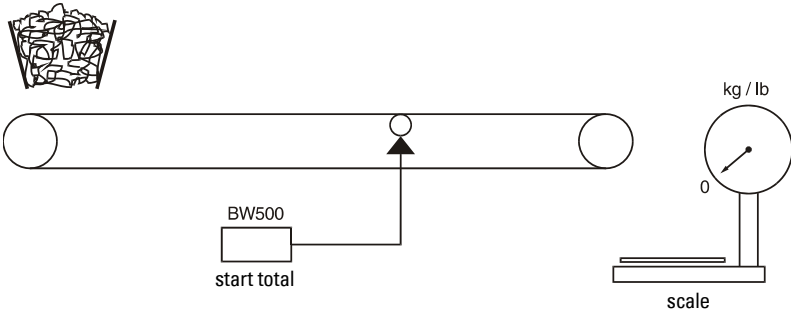

Access P019 and enter EDIT mode

P019 Manual Span Adjust	E
Select 1-% Change 2-Material Test	0

Press **1** **ENTER**

P598 Span Adjust Percentage	V
Enter Calculated +/- error	0.00

Press **ENTER**

P598 Span Adjust Percentage	E
Enter Calculated +/- error	0.00

Press **M** **1** **3** **ENTER**

if % change is negative, remember to enter the minus sign, e.g. -1.3

P017 Test Load Weight: MS1	V
Enter Test Load	56.78

e.g. the new test load value is displayed

Material Test

Access P019 and enter EDIT mode

P019 Manual Span Adjust	E
Select 1-% Change 2-Material Test	0

Press **2** **ENTER**

Material Test
Add to Totalizer 0-No, 1-Yes

if yes, the weight of the material test will be added to the totalizer, if no, material is added to test totalizer (4) only.

e.g. do not add weight of material test to totalizer

Press **0** **ENTER**

Material Test
Press ENTER to start

Press **ENTER**

Material Test	tonnes
Press ENTER key to stop	#.### t

the totalizer reading as the material test is run

Press **ENTER**

Material Test	964.032 t
Enter actual amount	tonnes

e.g. the weight totalized by the belt scale and BW500 and BW500/L

e.g. 975.633 kg is the actual weight of the material test

Press **9** **7** **5** **ENTER** **6** **3** **3** **ENTER**

Material Test Deviation	-1.19
Accept 0-No, 1-Yes	

e.g. the calculated deviation is displayed as a % of the actual weight

Press **1** **ENTER**

P017 Test Load Weight: MS1	V
Enter Test Load	56.78

e.g. the new test load value is displayed.

Verify the results of the span adjust by material test or return to normal operation.

Design Changes

Where parameters have been changed with a resultant impact on the calibration, they do not take effect until a recalibration is done.

If significant changes have been made, an initial zero (P377) and/or initial span (P388) may be required (see page 128).

Recalibration

To maintain the accuracy of the weighing system, periodic zero and span recalibration is required. Recalibration requirements are highly dependent upon the severity of the application. Perform frequent checks initially, then as time and experience dictate, the frequency of these checks may be reduced. Record deviations for reference.

The displayed deviations are referenced to the previous zero or span calibration. Deviations are continuously tallied for successive zero and span calibrations, and when exceed their limit, indicate an error message that the deviation or calibration is out of range.

Routine Zero

Note: To obtain an accurate and successful calibration, ensure that the required criteria are met. Refer to *Calibration Criteria* on page 156.

Press 

Zero Calibration. Current Zero.	551205
Clear belt. Press ENTER to start	

e.g. the current zero count

Press 

Zero Calibration in progress	%
Current Reading:	0.01 kg/m

e.g. the load reported while calibration is in progress

Calibration complete. Deviation	0.02
Press ENTER to accept value	551418

e.g. the calculated deviation in % of full span

e.g. the new zero count, if accepted

if

Calibration is out of range	
Deviation report:	403.37

if unacceptable, press  to restart

This indicates that the mechanical system is errant. P377, initial zero, should be used judiciously and only after a thorough mechanical investigation.

The cause of the increased deviation must be found and rectified. A zero recalibration as previously described can then be retried.

If the operator deems this deviation to be acceptable, set P377 to 1 to invoke an initial zero calibration. Further deviation limits are now based on this new initial zero.

Press 

Zero Calibration. Current Zero	551418
Clear belt. Press ENTER to start	

e.g. zero calibration is accepted and displayed as the current zero

Note: This is the end of zero calibration. Proceed with zero, or span recalibration, or return to **RUN**.

Initial Zero

Perform an initial zero if necessary when **calibration is out of range** message is shown. During this step the progress of the process will be shown on the display with a progress indicator in %.

Access P377 and enter EDIT mode

P377 Initial Zero	E
Enter 1 to start initial Zero	0

Press  

Zero Calibration. Current Zero	530560
Clear belt. Press ENTER to start	

e.g. the current zero

Press 

Initial Zero Calibration in progress	%
Current Reading:	#####

the zero count being calculated while calibration is in progress

Calibration complete. Deviation	0.00
Press ENTER to accept value	551413

e.g. the deviation in % from previous zero

e.g. the new zero count if accepted

if unacceptable, press  to restart

Press 

Zero Calibration. Current Zero	551413
Clear belt. Press ENTER to start	

e.g. the current zero count

Note: This is the end of zero calibration. Proceed with span recalibration or return to **RUN**.

Direct Zero

Use direct zero entry (P367) when replacing software or hardware, if it is not convenient to perform an initial zero. A record of the last valid zero count is required.

Access P367 and enter EDIT mode

P367 Direct Zero Entry	E
Enter Zero Count	0

Press **5** **5** **1** **4** **0** **1** **ENTER**

Zero Calibration. Current Zero	V
Enter Zero Count	551401

e.g. the last valid zero count

Auto Zero

The Auto Zero function is useful in outdoor applications where there are fluctuations in temperature, causing the zero to change throughout the day.

Auto Zero provides automatic zero calibration in the **RUN** mode under the following conditions:

- the auto zero input (terminals 29/30) is in a closed state; jumper or remote contact
- the load on the belt is within the programmed percentage (P371) based on the design load (P952)¹⁾
- the terminal and load status coincide for at least one belt revolution

The rate display is interrupted by the Auto Zero routine.

Rate	0.00 t/h	
Total 1:	0.00 tonnes	AZ

(AZ flashes on and off)

Note: t/h equals metric tonnes per hour

Calibration Complete. Deviation	0.0
Auto-Zero value	551410

e.g. typical zero and deviation values

The duration of the auto zero is one or more belt revolutions (P360). If either condition is interrupted during that period, the auto zero is aborted and the **RUN** display is resumed. After one belt revolution, another auto zero will be attempted if the input and load conditions are met.

¹⁾ Set Parameter P371¹⁾ to a value from 1 to 10%, default is 2%. See “P371 Auto Zero Initiation Upper Limit” on page 128.

If the resulting zero deviation is less than an accumulated 2% from the last operator initiated zero, the auto zero is accepted.

If the deviation is greater than an accumulated 2%, an error message is displayed. The error message is cleared after five seconds, however if a relay is programmed for diagnostics, it remains in alarm so long as the Auto Zero conditions are being met.

If material feed resumes during an auto zero function and is greater than the maximum load on the belt (P371), the totalizing function is maintained.

Routine Span¹⁾

Note: To obtain an accurate and successful calibration, ensure that the required criteria are met. Refer to *Calibration Criteria* on page 156.

Press 

Span Calibration. Current Span	41285	e.g. the current span count
Setup test. Press ENTER to start		

if

Zero should be done prior to Span Setup test. Press ENTER to start.	do a zero calibration or press 
--	--

Press 

Span Calibration in progress	%	the load reported while calibration is in progress.
Current Reading:	55.56 kg/m	

Calibration complete. Deviation	0.03	e.g. the deviation in % from previous span
Press ENTER to accept value	41440	e.g. the new span count, if accepted
if unacceptable, press  to restart		

if

Span Count too Low. Press CLEAR to continue.	signal from load cell too low: ensure shipping brackets are removed and proper test weight or chain is applied during span
---	--

Calibration aborted Belt speed is too low:	e.g. belt speed is <10% of design (P014)
---	--

¹⁾ During this step the progress of the process will be shown on the display with a progress indicator in %

Calibration is out of range	
Deviation Error:	XX.XX

This indicates that the mechanical system is errant. The use of P388, initial span, should be used judiciously and only after a thorough mechanical investigation has been exercised.

Find and rectify the cause of the increased or decreased deviation. Then re-try a span recalibration.

If this deviation is still unacceptable, set P388 to 1 to invoke an initial span calibration. Further deviation limits are now based on this new initial span.

Press 

Span Calibration. Current Span	41440	e.g. span calibration is accepted and displayed as the current value
Setup test. Press ENTER to start		

Initial Span¹⁾

Note: Perform an initial span when a **calibration out of range** message appears.

A zero calibration should be performed prior to performing a span calibration.

Access P388 and enter EDIT mode

P388-01 Initial Span	E
Enter 1 to start Initial Span	0

Press  

Span Calibration. Current Span	41440	e.g. the current span count
Setup test. Press ENTER to start		

If

Zero should be done prior to Span	do a zero calibration or clear
Setup test. Press ENTER to start	

Press 

Initial Span Calibration in progress	the span count being calculated while calibration is in progress
Current Reading:	

¹⁾ During this step the progress of the process will be shown on the display with a progress indicator in %.

Calibration complete. Deviation	0.00
Press ENTER to accept value	41900

the deviation is reset
e.g. the new span value if accepted
if unacceptable, press  to restart

Press 

Span Calibration. Current Span	41900
Setup test. Press ENTER to start	

e.g. the current span count

Note: End of span calibration. Remove the test weight and return to **RUN**.

Direct Span

Direct span entry (P368) is intended for use when replacing software or hardware, and when it is not convenient to perform an initial span. A record of the last valid span count is required.

Access P368 and enter EDIT mode

P368-01 Direct Span Entry	E
Enter Span Count	0

Press       

P368-01 Direct Span Entry	V
Enter Span Count	41900

e.g. the last valid span count

Multispan¹⁾

The BW500 offers a multispan function, which allows the BW500 to be calibrated for up to eight different feed conditions that would produce varying load characteristics. Different feed conditions are typically related to the running of different materials or multiple feed locations. The varying load characteristic often has a bearing on the belt tension, and is observed especially when in close proximity to the scale. To accommodate such scale applications, a span correction can be made by selecting and applying the appropriate span.

Since every material has its own unique physical properties, and may load the belt differently, a span calibration may be required for each material to realize maximum accuracy.

In the case of different feeder locations, a span calibration may be required to match each feedpoint or combination of feedpoints.

¹⁾ Not available with BW500/L.

Each time one of the eight conditions is in effect, the corresponding multispans is selected prior to putting the BW500 into the **RUN** mode. The selection is made by either changing the multispans operation number, accessed via P365, or by external contacts connected to the Auxiliary input, and programmed via P270.

To enable multispans operation, the following must be addressed.

- connections
- programming
- calibration
- operation

Connections

If the span selection is to be done by remote contact, the following connections would apply. Otherwise, no additional connections to the BW500 are required.

Multispans Selection of Spans 1 and 2

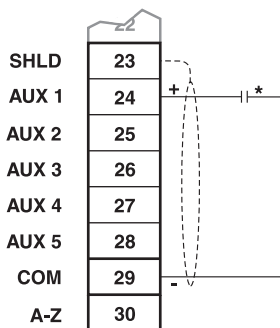

Multispans Selection of Spans 1 to 8

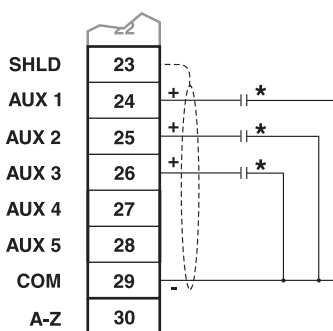

*Remote contact can be from relay, open collector switch, or BCD switch.

Programming

Access P365 and enter EDIT mode

P365 Multispans	E
Select [1-8]	0

Span 1 will have already been set as part of the Start Up and initial calibration. Therefore, select 2.

Access P017 and enter EDIT mode

P017 Test Load: Weight MS2	E
Enter test load	0

Enter the test load value, and press **SPAN** to do a span calibration.

To do a span calibration for another condition, (i.e. span 3 or 4 etc.), access P365 and repeat these steps for each condition. As with any initial span, follow the span calibration for each multispan with a material test and factoring.

To use remote span selection, auxiliary Inputs, 1 and/or 2 or 3, are programmed to read the contact state as the span selection. Remote selection overrides the keypad (or Dolphin Plus) selection. The auxiliary inputs override the keypad selection.

Access P270 and enter EDIT mode

P270-01 Auxiliary Input Function	E
Select Function [0-13]	0

Enter **6**. This programs Auxiliary Input 1 (terminal 24) to read the contact state for span selections: 1 or 2.

If spans 3 and/or 4 are to be used:

Access P270 and enter EDIT mode (when using spans 3 and/or 4)

P270-02 Auxiliary Input Function	E
Select Function [0-13]	0

Enter **6**. This programs Auxiliary Input 2 (terminal 25), in conjunction with Auxiliary input 1 to read the contact state for span selections 3 and 4.

If spans 5, 6, 7, and/or 8 are to be used:

Access P270 and enter EDIT mode (when using spans 5 to 8)

P270-03 Auxiliary Input Function	E
Select Function [0-13]	0

Enter **6**. This programs Auxiliary Input 3 (terminal 26), in conjunction with Auxiliary input 1 and Auxiliary input 2 to read the contact state for span selections 5, 6, 7, and 8.

Remote selection of a span is not enabled until a span calibration has been done. Initial span selection must be done via the Multispan parameter, P365.

Initial multispan calibration or span selection is made via the Multispan parameter (P365).

Operation

When span calibration is done, press **RUN** to revert to the **RUN** mode.

Rate kg/h	0.00 kg/h	MS 2
Total 1:	0.00 kg	

multispan 2

e.g. if there is no material on the belt and the conveyor is running. The current rate is 0 and no material has been totalized.

When the material to be run on the belt changes, the multispan is changed to the corresponding span. This is completed either by changing the span value entered in P365, or by closing the appropriate contacts connected to the programmed Auxiliary inputs.

Span	Auxiliary Input Aux 1	Multispan Selection Aux 2	Multispan Selection Aux 3
1	- -	- -	- -
2	- /	- -	- -
3	- -	- /	- -
4	- /	- /	- -
5	- -	- -	- /
6	- /	- -	- /
7	- -	- /	- /
8	- /	- /	- /

It may be required to reset or note the totalizer value, as the process materials being conveyed change. Refer to *Operation* on page 63.

Linearization applies concurrently to spans.

Online Calibration¹⁾

The Online Calibration feature may be used to routinely check, and if necessary adjust, the Span calibration in **RUN** mode, without interrupting the material flow or process.

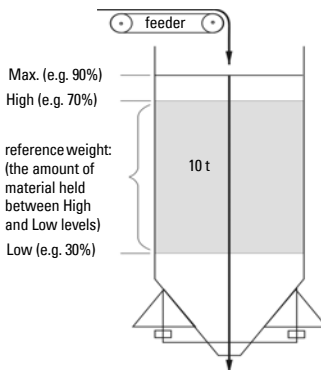

Install a weigh bin, (bin or silo equipped to provide a 4 to 20 mA output proportional to weight), preceding the material infeed.

Connect the weigh bin to one of the mA inputs on the optional mA I/O board of the BW500: either mA input 1, terminals 5 and 6; or mA input 2, terminals 7 and 8.

Install a material feed control device, preceding the weigh bin.

¹⁾ Not available with BW500/L.

Note:

- Press **PAR** twice, to enter a parameter number directly.
- Whenever you wish to change a value, press **ENTER** to enable the EDIT mode.

Press **ENTER**

P355 Online Calibration Feature	E	EDIT mode: value can be changed
Select: 0-Off, 1-On	0	

Select the Online Calibration feature:

Press **1** **ENTER**

Access

P355 Online Calibration Features	V	Value is accepted
Select: 0-Off, 1-On	1	

Enter the weigh bin reference weight, (the amount of material the bin holds between the high and low levels), in units selected in P005.

Press **ENTER** **1** **0** **ENTER**

Access

P356 Online Calibration	V	e.g. reference bin weight
Enter Reference Weight	10.000	

Enter the max., high, and low limit setpoints as a percentage in P357.

Press **ENTER** **9** **0** **ENTER**

Access

P357-01 Online Calibration Limits	V	limit as a percentage
MAX Limit:	90.0	

Press **ENTER** **7** **0** **ENTER**

Access

P357-02 Online Calibration Limits	V
HIGH Limit:	70.0

Press    

Access

P357-03 Online Calibration Limits	V
LOW Limit:	30.0

Calibrate the mA inputs on the BW500 to the 4 and 20 mA levels of the weigh bin. 4 mA is calibrated with the weigh bin empty, using P261-01 or -02. 20 mA is calibrated with the weigh bin full, using P262-01 and P262-02.

Assign one of the mA inputs for the Online Calibration function.

Press   

Access

P255-01 mA Input Function	V
Select 0, 1-PID SP, 2-PID FV, 3-OCAL	3

e.g. mA input 1 set to 3

Assign one of the 5 relays, P100-01 to P100-05, to the Online Calibration function.

Press   

Access

P100-01 Relay Function	V
Select Function [0-9] (see manual)	9

e.g. relay 1 set to 9

Program the assigned relay using P118, relay logic, so that when you connect the assigned relay to the weigh bin material feed control device, the weigh bin material feed stops when the Online relay is energized.

Activate Online Calibration

Press   

Access

P358 Online Calibration Features	V
0-OFF, 1-ACTIVE	

Note: For remote access, Online Calibration can also be activated using one of the Auxiliary inputs (refer to *P270* on page 122).

When the Online Calibration is activated, normal operation continues until the weigh bin fills to the maximum level, (90% in the example shown). During the filling stage, the current level is displayed as a percentage.

Online Calibration -	LOW > 19%	current level displayed as percentage
Wait for LEVEL > MAX	RLY	

When the maximum limit is reached, the relay assigned to the Online Calibration function energizes to stop the weigh bin material feed.

Online Calibration -	94% > MAX
Wait for LEVEL < HIGH	RLY 1

Material continues to be discharged from the weigh bin, and when the level drops to the High limit (70% in the example) the Online totalizer is automatically activated.

Online Calibration -	TOTAL 3.71 tonnes	running total
Calibration in progress	RLY 1	

When the Low limit (30%) is reached, the totalizer is deactivated and the assigned relay is de-energized, which reopens the material feed to the weigh bin.

The BW500 Online material total, the amount of material totalized between the High and Low limits, is compared to the value entered in P356. The deviation percentage between these values and the new Span count value is displayed.

Online Calibration -	Deviation	2.51%	deviation percent
Press ENTER to accept	New span	22280	new Span count value

Press  to accept the results.

Online Calibration Complete			
Press ENTER to accept	New span	22280	

Note:

- Deviation must be no greater than $\pm 12\%$ of the initial span or it will not be accepted.
- For remote access, Online Calibration can be accepted using one of the Auxiliary inputs: refer to *P270* on page 122.

If you want to reject the results and return to **RUN** mode, press .

Rate	0.00 t/h
Total 1:	10.15 t

Note: t/h equals metric tonnes per hour

Note: For remote access, to return to **RUN** mode, program one of the Auxiliary inputs: refer to *P270* on page 122

If you want to reject the results and perform another online calibration, press  to return to P358.

Access

P358 Online Calibration Features	V
0-OFF, 1-ACTIVE	1

Press  

If the deviation is greater than $\pm 12\%$:

Calibration is out of range
Deviation Error:

1. Rerun online calibration to verify the deviation: press  to return to P358.
2. Verify the mechanics of the belt scale: carry out material tests to ensure the readings are correct. (See page 42)
3. If the mechanics are functioning correctly, perform an initial span using P388. (See page 49.)

Factoring

Note: For optimum accuracy in the factoring results, a routine zero calibration is recommended.

To calculate the value of a new or unknown test weight to the current span, the factoring procedure is used.

With the belt empty, the test weight in place, and the conveyor running:

Access P359 in VIEW mode

P359 Factoring	V
Select 1-Weight, 2-Chain	

Press   

Factoring Weight
Place weight and press ENTER.

e.g. factor the test weight

Press 

Factoring Weight	
Factoring in progress	##.## kg/m

the load reported while factoring is in progress

Factoring Weight	
Press ENTER to accept value	45.25

e.g. the new factor, if accepted

Press 

P017 Test Load Weight:	V
Enter Test Load	45.25

e.g. the current test load value

Factoring is complete. Remove test weight and return to RUN mode if desired.

Note: If multispan function is used, the test load value is stored for the current multispan only.

Linearization

Conveyor applications where the ideal belt scale location has been compromised, or where there is a high degree of variation in belt tension, typically cause the belt scale to report load non-linearly. The BW500 and BW500/L provides a linearizing function (P390 - P392) to correct for the deficiency in the weighing system and to provide an accurate report of the actual process.

To verify that the cause of the non-linearity is not mechanical:

- Run the conveyor belt empty and stop it.
- Lift the belt off of the scale and suspend various test weights to the scale. If the load reported by the BW500 and BW500/L is non-linear, a mechanical problem is indicated. Refer to the belt scale manual to resolve the non-linearity by improved installation or repair.

If it is determined that the non-linearity is due to the weighing application, and not the actual belt scale, apply linearization by performing the following:

- zero calibration
- span calibration at 90 to 100% of design rate
- material tests at 90 to 100% of design rate
- manual span adjust if required
- material tests at 1 to 5 intermediary flow rates where compensation is required.

Note: Compensation points must be at least 10% of the design load apart.

- calculate the percentage compensation for each flow rate tested.

$$\% \text{ compensation} = \frac{\text{actual weight} - \text{totalized weight}}{\text{totalized weight}} \times 100$$

where:

actual weight = material test

totalized weight = BW500 and BW500/L total

Note:

- After the compensation has been programmed into the BW500 and BW500/L, a material test should be run to verify the effect of linearization.
- If additional compensation is required, it must be based on new material tests performed with the linearization turned off (P390 = 0).

Example:

A non-linearity with respect to the ideal response exists in a belt scale application with design rate of 200 t/h. It is decided to do material tests at 15, 30, 45, 60 and 75% of the design load. After performing a zero and a span calibration at 100% of the design load, followed by material tests and manual span adjust, five material tests were performed at 30, 60, 90, 120 and 150 t/h, as indicated by the BW500. The following data was tabulated. (This example is exaggerated for emphasis).

The material tests should be run at same belt speed, representative of normal operation; in this case 1.2 m/s. For each rate, record the corresponding load value by scrolling to the BW500 load display during running conditions or by calculation.

$$\text{load} = \frac{\text{rate}}{\text{speed}}$$

BW500 load	material test	BW500 total	compensation^{a)}
kg/m	tonnes	tonnes	%
6.94	2.5	2.8	-10.7
13.89	5.0	4.5	11.1
20.83	7.5	7.9	-5.1
27.78	10.0	9.2	8.7
34.72	12.5	13.3	-6.0

^{a)} calculation example: % compensation = [(2.5 – 2.8) x 100]/2.8

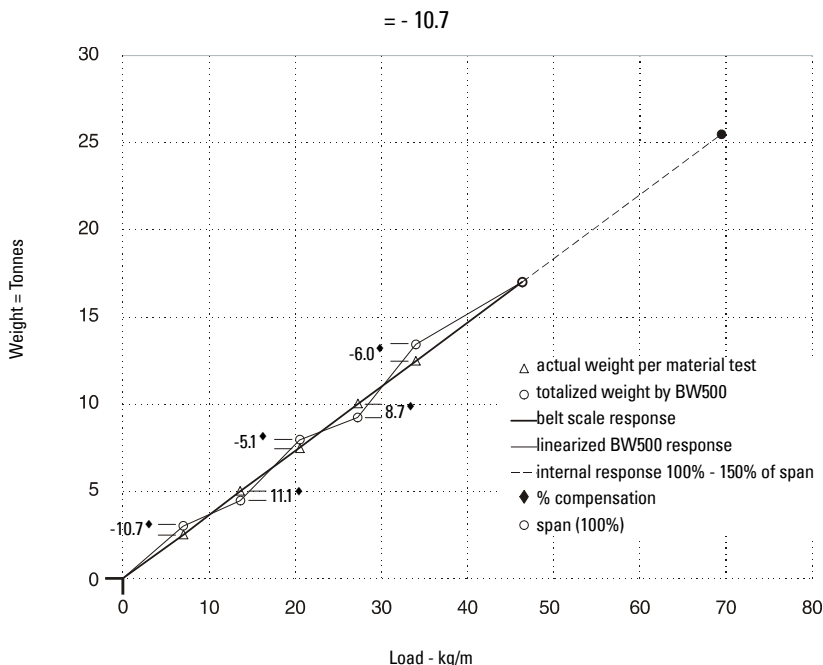

Program the BW500 as follows:

Parameter	Function
P390 = 1	linearization – on
P391-01 = 6.94	point 1, load
P391-02 = 13.89	point 2, load
P391-03 = 20.83	point 3, load
P391-04 = 27.78	point 4, load
P391-05 = 34.72	point 5, load
P392-01 = - 10.7	point 1, compensation
P392-02 = 11.1	point 2, compensation
P392-03 = - 5.1	point 3, compensation
P392-04 = 8.7	point 4, compensation
P392-05 = -6.0	point 5, compensation
Note: Often only one point of compensation is required, usually at a low load value. In the prior example, if compensation was only required at 6.94 kg/m, the programming could be as follows. Compensation is optimized by establishing the next load value that agrees with the material test, hence where compensation is zero and entering it as the next compensation point.	
P390 = 1	linearization on
P391-01 = 6.94	point 1, load
P391-02 = 20.00	point 2, load
P392-01 = - 10.7	point 1, compensation
P392-02 = 0	point 2, compensation

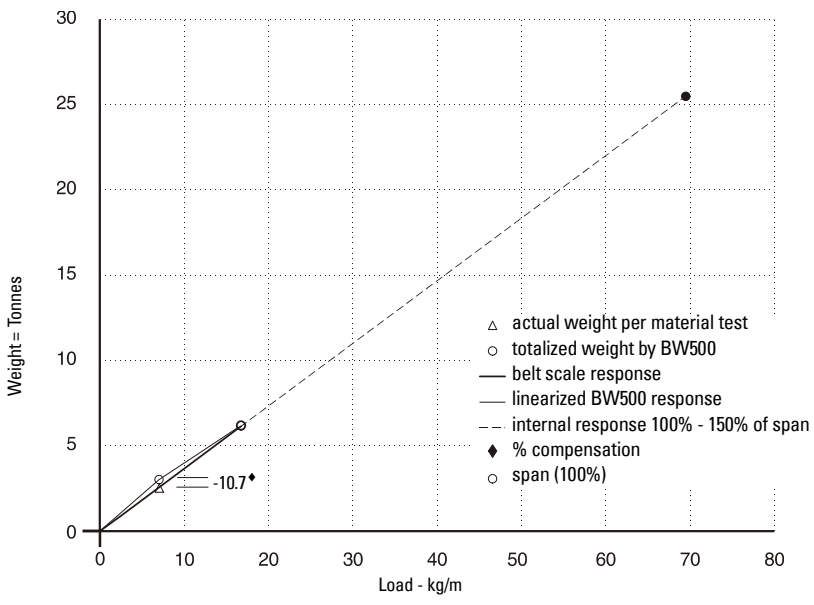

For Parameter reference, go to Parameters on page 111.

Operation

Load Sensing

For the BW500 and BW500/L to calculate rate and totalize material flow along the belt conveyor, a load signal representative of weight of material on the belt is required. The load signal is provided by the belt scale. The BW500 and BW500/L is compatible with belt scales fitted with 1, 2, 4, or 6¹⁾ strain gauge type load cells. To function with LVDT type sensors, an optional LVDT conditioning card is required.

Refer to *Specifications* on page 5, and *Installation* on page 9 for belt scale requirements and connection.

Speed Sensing

For the BW500 and BW500/L to calculate rate and totalize material flow along the belt conveyor, a speed signal representative of belt speed is required. For optimum accuracy of the weighing system, and both constant and variable speed applications, a speed sensor is required. The design speed (P014) and speed constant (P015) need to be programmed.

In constant speed applications (no speed sensor), the BW500 can be programmed to provide an internal speed signal. This is achieved by entering the design speed (P014) and providing a contact closure across speed input terminals (17/18). The speed constant (P015) defaults to 'jumped'. This contact should change to open when the conveyor is idle to prevent errant totalization.

In applications with two speed sensors, the BW500 can be programmed to provide differential speed. % slip can be calculated, using the difference between the two speed signals with reference to the first speed.²⁾

Refer to *Specifications* on page 5 and *Installation* on page 9 for speed sensor requirements and connection.

Differential Speed Detection²⁾

Dual point speed sensing is used for monitoring speed at two points in the system where a difference in speed can be detrimental to the equipment or its operation. The two speed sensors are typically applied on belt conveyors to give an alarm if excessive slip between the head pulley and tail pulley is detected. The secondary speed sensor is especially useful on variable speed conveyors, and may also be used to detect a malfunction in the primary speed sensor.

The BW500 provides a 12 V DC, 150 mA maximum, regulated power supply for both speed sensors. The primary speed sensor is used for all "Run" display integration, and is the reference value for differential speed detection. The primary speed sensor is generally reserved for the driven device (tail pulley). The second speed sensor is

¹⁾ Not available with BW500/L

²⁾ Differential speed detection is not available on the BW500/L

generally reserved for the driving device (head pulley), and is used for comparison to the primary speed sensor, for differential speed detection only.

The second speed signal is compared to the primary speed signal, and will initiate an alarm condition if the second speed signal is outside the programmed high and low alarm setpoints.

Connect the second speed sensor as shown in the Installation section (refer to *Auxiliary Speed Sensor* on page 21), and program the second speed sensor as described in the following steps:

1. Program one of the Auxiliary Inputs as a Speed Sensor input P270-01 to 05 = 16 (Speed Sensor).
2. Program second speed sensors speed constant P015-02 = pulses per meter or foot (Refer to *Start Up* on page 28, for speed sensor programming).
3. Program one of the alarms for Differential Speed Detection alarm P100-01 to 05 = 10 (Speed Differential).
4. Program the High Alarm setpoint P101-01 to 05 = 110% (default).
5. Program the Low Alarm setpoint P102-01 to 05 = 90% (default).

Moisture Compensation¹⁾

Moisture Compensation is used to compensate for the moisture component of the material being weighed. It factors out the moisture component of load, rate and total for all multispans selected. The factored value is meant to report the dry mean values of the material being conveyed.

The BW500 receives the static load cell signal, and adjusts the value of the load being displayed and integrated by the moisture percentage. The mA I/O card is required to accept the mA signal from the Moisture Meter. This mA signal can represent 0 to 100% moisture. The moisture percentage is displayed in P398-01. Using P398-02, the moisture percentage can be represented as a percentage of mass to be deducted from the total mass¹⁾.

¹⁾ The BW500/L allows for a fixed moisture content to be entered. See “P398-01 Moisture Content” on page 129.

Example:

Setting P398-02 = 30% will allow the 4 - 20 mA input to correspond to 0 - 30% moisture.

The Zero and Span calibration is not affected by the presence of a moisture meter. It is understood that the calibrations are performed using dry static weights.

The Moisture Meter must be connected to the appropriate mA input and programmed as described in the following steps:

1. Enable mA input function for moisture compensation P255-01 or 02 = 4 (moisture compensation).
2. Set appropriate mA input range P250-01 or 02 = 2 (default is 4 - 20 mA).
3. Set mA input moisture ratio P398-02 = 100% (default).
4. Observe moisture percentage using P398-01.

Incline Compensation¹⁾

Incline compensation is used to compensate for the varying vertical force component applied to the belt scale due to varying inclination of the conveyor. The BW500 and BW500/L receives the static load cell signal, and adjusts the load displayed and integrated, by a factor of COSINE of the angle of incline.

The Inclinometer should be mounted to the conveyor stringer, parallel to the center of the belt scale. The mA I/O card is required to accept the mA signal from the Inclinometer. This mA signal must represent -30 to 30°. The incline angle is displayed in P399.

The dynamic load cell signal will vary with the incline of the conveyor. The BW500 and BW500/L load display and integration values will remain constant for the given load on the belt scale through the specified range of inclination.

The Zero and Span calibrations of the BW500 and BW500/L will be adjusted based on the angle of incline of the conveyor. The Zero and Span calibration can be performed at any angle. However, if incline compensation will be used, it must be enabled for all Zero and Span calibrations¹⁾.

The Inclinometer must be connected to the appropriate mA input and programmed as described in the following steps:

1. Enable mA input function for incline compensation P255-01 or 02 = 5 (Incline compensation).
2. Set appropriate mA input range P250-01 or 02 = 2 (default is 4 - 20 mA).
3. Observe incline angle using P399.

Modes of Operation

RUN is the normal or reference mode of operation. It continuously processes the load and speed signals from the belt scale to produce internal load, speed and rate signals, which are in turn used as the basis for totalization, mA output, relay control, and communication data. The **RUN** display is programmed (P081) to scroll through rate,

¹⁾ The BW500/L allows for a fixed inclined angle to be entered. See "P399 Incline Sensing" on page 130.

totalization (P647), load and speed; either manually by pressing the enter key, or automatically.

Rate
Total 1

Rate
Total 2

Load
Speed

If the BW500 is programmed for batch control, the batch display is added to the display scroll. Refer to *Batch Control* on page 134 for more information.

From the **RUN** mode, access to the **PROGRAM** mode, and zero and span calibration is made.

The **PROGRAM** mode allows viewing and, with security permission (P000), editing parameter values. During **PROGRAM**, **RUN** mode functions are still active, i.e.: rate, relay, mA output and totalization.

If the **PROGRAM** mode is left idle for a period of ten minutes, it automatically reverts to **RUN** mode.

Zero and span calibrations effectively halt the **RUN** mode while they are in progress. During this time, totalization ceases, and all mA outputs, except for PID, fall to zero.

Damping

Damping (P080) provides control over the speed at which the displayed readings and output functions respond to changes in their respective input function: load, speed and the internal rate signals. Changes in the displayed rate of material flow, material loading and belt speed are controlled by the damping. Relay alarm functions based on input functions of rate, load and speed, respond to the damped value.

Damping consists of a first order filter applied to the signal (reading or output value).

If mA damping (P220) is enabled (value other than 0), then the damping (P080), as it pertains to the mA function, is overridden, and responds independently at the specified mA output damping rate (P220).

Note: Damping (P080 or P220) is not applicable to the mA output when programmed for PID function (P201 = 4).

mA I/O (0/4-20 mA)

Output

The standard BW500 and BW500/L provides one isolated mA output. The output can be assigned (P201) to represent rate, load or speed. The output range can be set to 0 - 20 mA or 4 - 20 mA (P200). The 0 or 4 mA value corresponds to empty or zero condition, whereas the 20 mA value corresponds to the associated design value: rate (P011), load (P952), or speed (P014). The mA output can be limited for over range levels of 0 mA minimum and 22 mA maximum (P212 and P213 respectively). The output 4 and 20 mA levels can also be trimmed (P214 and P215 respectively) to agree with a milliammeter or other external mA device.

The mA output value can be tested to output a prescribed value using parameter P911. Refer to *P911* on page 145.

The optional mA I/O board provides two additional mA outputs¹⁾, programmable as outputs 2 and 3, using the same parameters as the standard output (1). If programmed for PID control, output 2 is assigned to PID control loop 1 and output 3 is assigned to PID control loop 2.

Input¹⁾

The optional mA I/O board provides two mA inputs, programmable as inputs 1 and 2. If programmed for PID control, generally, input 1 is assigned to PID control loop 1 and input 2 is assigned to PID control loop 2.

The input range can be set to 0-20 mA or 4-20 mA (P250), and assigned a function (P255), e.g. PID setpoint. The 4 and 20 mA levels can be trimmed (P261 and P262) to agree with an external device. The external device could be a moisture sensor, or an inclinometer.

Relay Output

The BW500 offers five single pole single throw (SPST) relays that can be assigned (P100) to one of the following alarm functions, the BW500/L offers two relays of the same type:

- rate: relay alarms on high and/or low material flow rate.
- load: relay alarms on high and/or low belt load.
- speed: relay alarms on high and/or low belt speed.
- differential speed¹⁾: relay alarms if second speed signal outside high and/or low alarm setpoints.
- diagnostic^{1) 2)}: relay alarms on any error condition as it is reported. See “Troubleshooting” on page 148.
- PID^{1) 2)}: PID control setpoint deviation
- batch pre-warn¹⁾
- batch setpoint¹⁾

For rate, load, and speed alarm functions, the high and low alarm setpoints (P101 and P102 respectively) are required and must be entered in the appropriate units. The high alarm setpoint acts as the setpoint deviation alarm for relays programmed for PID setpoint deviation.

The on/off actuation at both high and low setpoints is buffered by the damping (P080) and the programmable dead band (P117), to prevent relay chatter due to fluctuations. The relay is normally energized; holding the normally open (n.o.) contact closed (can be programmed for reverse operation, P118). Upon an alarm condition, the relay is de-energized and the relay contact is opened. Once in alarm, the relay remains in alarm state until the alarm condition is removed.

¹⁾ Not available with BW500/L

²⁾ Is offered only if the PID system (P400) is enabled.

Example:

P014 = 2m/s, design speed

P100 = 3, belt speed

P101 = 100% (2 m/s)

P102 = 20% (0.4 m/s)

P117 = 2% (0.04 m/s)

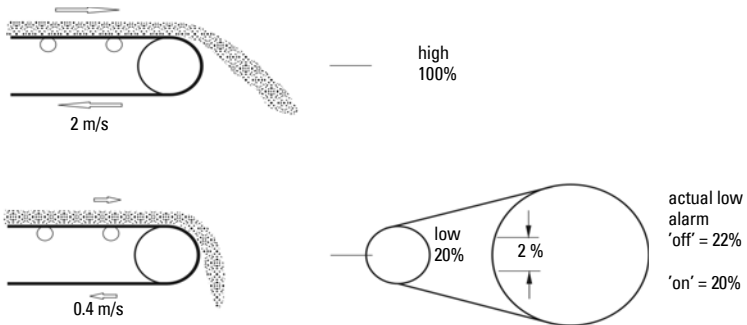

alarm 'on' is with relay de-energized

Totalization

The totalization function is based on the internal rate (mass per unit time) signal proportional to belt speed and load on the associated belt scale. It is not affected by the damping function (P080). The rate signal is sampled several times a second to accurately count the mass of material conveyed. The count is held in the master totalizer used to increment the internal totalizers and to produce a pulse signal for the remote totalizers.

The BW500 provides several separate totalizer functions:

Internal totalizers

- local display (totalizers 1 and 2)
- verification totalizer (totalizer 3)
- material test totalizer (totalizer 4)
- batch total (totalizer 5)

External totalizers

- totalizer outputs (remote totalizers 1 and 2)

To avoid totalizing material at flow rates below the low flow rate limit, the totalizer drop out limit (P619) is set to a percentage of the design load. Below this limit, totalization stops. When material flow returns to a rate above the drop out limit, totalization resumes.

Totalizer resolution or count value is set by the respective internal (P631) and external (P638) totalizer¹⁾ resolution parameters.

¹⁾ If the resolution selected causes the totalizer to lag behind the count rate, the next possible resolution is automatically entered.

Example:

Internal totalizer 1

Given: P005 = 1 (t/h)
P631 = 4

Then: totalizer count increments by 10 for each 10 metric tonnes registered

External totalizer 1

Given: P005 = 1 (t/h)
P638 = 5

Then: contact closure occurs once for every 10 metric tonnes registered

For remote totalization, the contact closure duration (P643) is automatically calculated upon entry of the design rate (P011) and remote totalizer (P638) parameters, so that the duration of contact closure allows the relay response to track the total up to 150% of the design rate. The value can be changed to suit specific contact closure requirements, such as in the case of programmable logic controllers. If the duration selected is inappropriate, the next possible duration is automatically entered.

External Totalizer Calculation Example:

Design Rate = 50 t/h (P011)

External Totalizer Resolution Selected = 0.001 (P638 = 1)

External Totalizer Contact Closure Time selected = 30 msec (P643 = 30)

External Totalizer Cycle Time = 60 msec (External Totalizer Contact Closure Time X 2)

1. Calculate the maximum number of pulses per second for the Contact Closure Time selected (P643).

Maximum Number of pulses per second

$$= 1 / \text{External Totalizer Cycle Time}$$

$$= 1 / 0.060$$

$$= 16.6 \text{ (which is rounded to a whole number of 16 in the BW500)}$$

2. Calculate the pulses per second required for the External Totalizer Resolution selected (P638).



$$\text{Pulses Per Second} = \frac{\text{Design Rate} \times 150\%}{\text{External Totalizer Resolution} \times 3600}$$

$$= \frac{50 \text{ t/h} \times 150\%}{0.001 \times 3600}$$

$$= 20.83$$

Because the required 20.83 pulses per second is greater than the maximum 16 pulses per second, the External Totalizer Resolution of 0.001 will not allow the External Totalizer to track up to 150% of the design rate. The External Totalizer Resolution will have to be increased to 0.01 or the External Totalizer Contact Closure Time will have to be decreased.

The totalizers are reset through the master reset (P999), the totalizer reset (P648), or through the keypad.

- master reset: the reset of all totalizer functions is included in the master reset.
- totalizer reset: totalizer reset can be used to reset internal totalizers 1 and 2, or totalizer 2 independently. Resetting the internal totalizers 1 and 2 resets the internal registers for external totalizers 1 and 2.
- keypad: pressing   while in the **RUN** mode resets internal totalizer 1

Placing the internal totalizers on to the display scroll of the **RUN** mode is controlled by the totalizer display parameter (P647); displaying either one or both totalizers.

PID Control¹⁾

The PID control algorithm in the BW500 is designed specifically to work for feed rate control applications. It is based on motor control type algorithms and includes several anti-wind up provisions.

One way to prevent wind up is to monitor the input speed frequency from the weighfeeder. If the input frequency drops below 5 Hz, the PID control output freezes at its current value. Otherwise, the output winds up to 100% if the feeder is shut off while there is still a set point greater than zero. When the feeder is turned back on, there would be a surge of product flow until the system regains stability. With anti-wind up, the feeder can be stopped and started with minimal disruption to the controlled flow rate.

To operate the BW500 as a controller, address the following:

- hardware
- connections
- setup and tuning
- programming

Hardware

For the BW500 to operate as a controller, install the optional mA I/O board. Refer to *Installation* on page 9.

Connections

Connections to process instruments, in addition to standard operating connections, must be made.

Refer to:

- *Installation* on page 9, specifically:
- *Relay Output* on page 24, for relay connections
- *mA I/O board* on page 12, for mA input and output connections
- *Auxiliary Inputs* on page 22, for optional remote control

Connect the BW500 as either a:

1. setpoint controller – load control
2. setpoint controller – rate control
3. setpoint controller – rate and load control
4. setpoint controller – external process variable with or without rate and load control

PID loop	mA output	terminals (mA I/O)	mA input	terminal (mA I/O)
1	2	1 & 2	1	5 & 6
2	3	3 & 4	2	7 & 8

¹⁾ Not available on the BW500/L.

Setpoint Controller – Rate Control

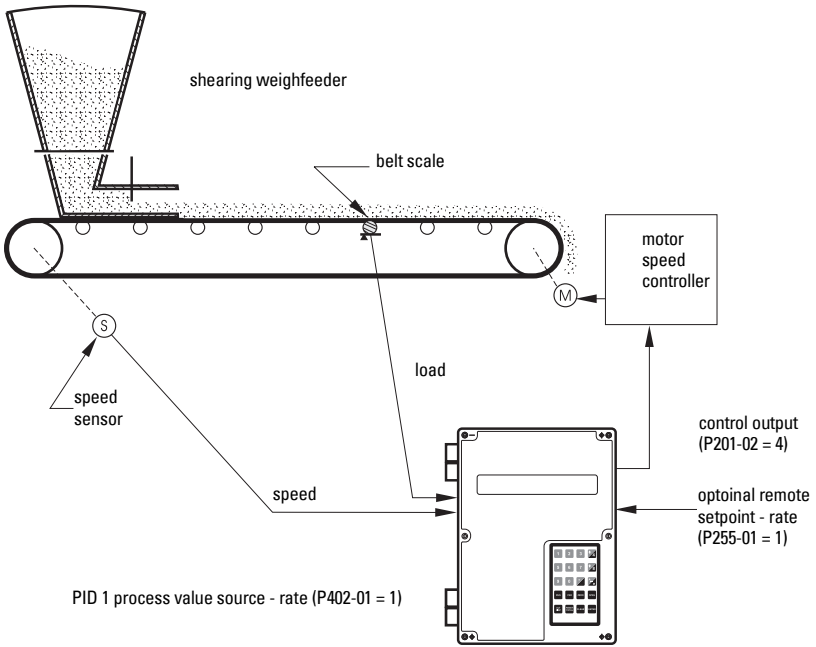

Setpoint Controller – Load Control

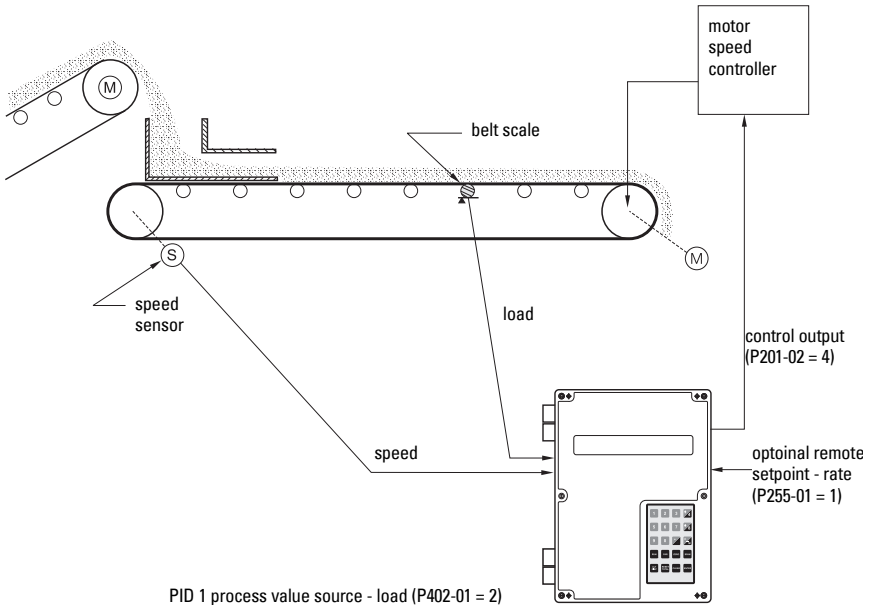

PID Control

Setpoint Controller – Master/Slave Control

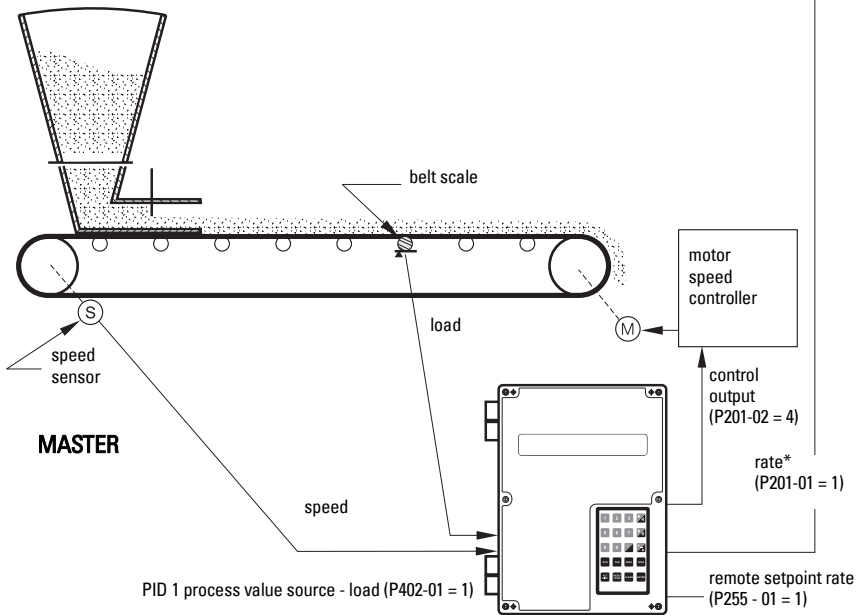
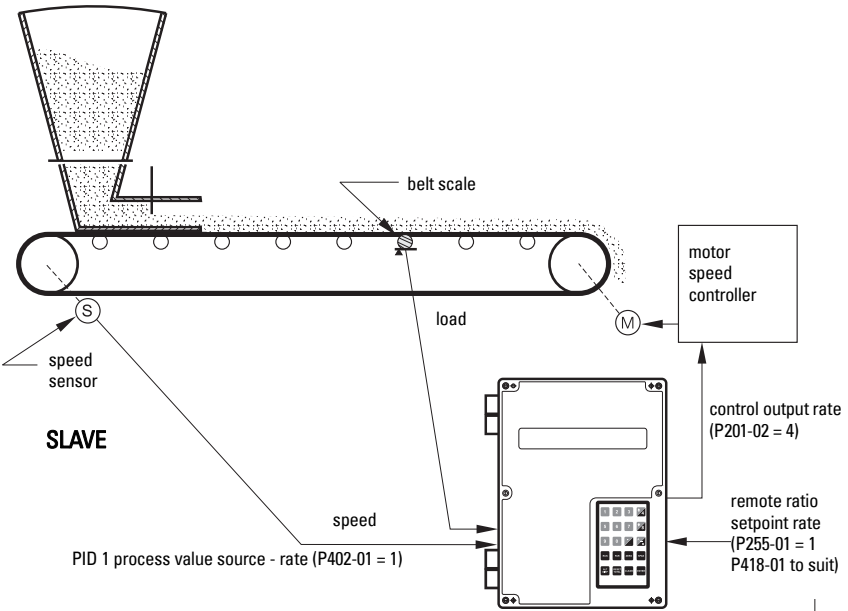

*P201-03 = 1 also applicable

Setpoint Controller – Rate and Load Control

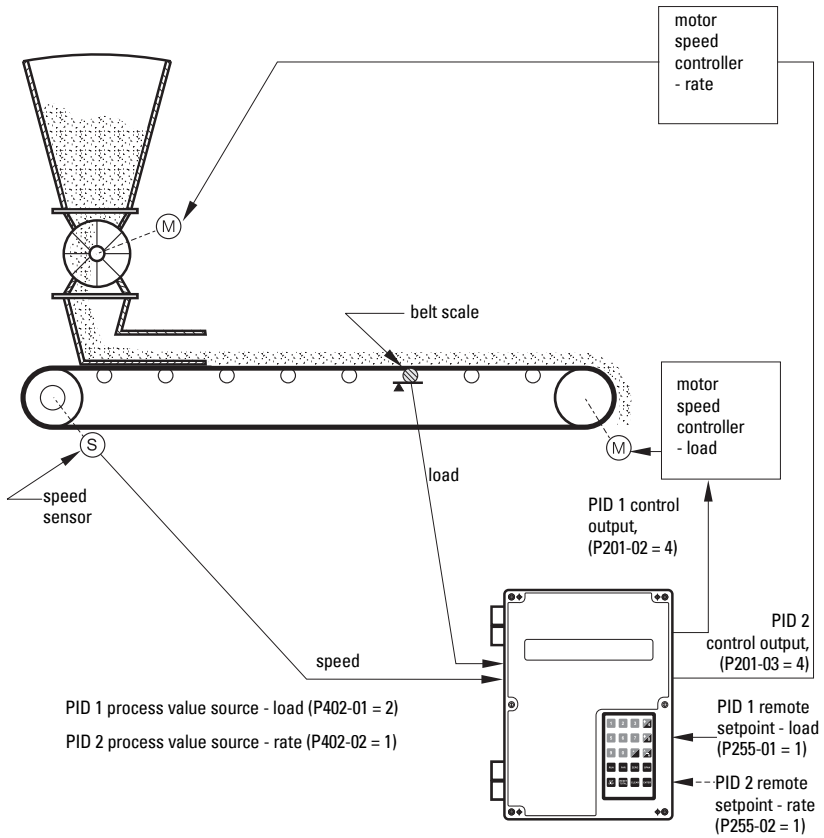

PID Control

Setup and Tuning

Before proceeding, it would be beneficial to qualify and quantify the terms you will encounter in the setup and tuning of the control system.

Proportional Control (Gain), *P*

The *P* term on the BW500 adjusts the control output based on the difference between the set point and the measured flow rate. A higher *P* term makes the BW500 more sensitive and faster to react to changes or disturbances. If set too high, the BW500 becomes less stable, and more susceptible to oscillations in the control output.

- allowable input range: 0.000 to 2.000
- typical operating range: 0.300 to 0.600
- default value: 0.400

The control output cannot reach the setpoint using only the P term. Since the P term acts on the difference between the **setpoint** and **process variable**, a small difference between these two always exist and the difference is never zero. A small P term can get the process very close to set point, but it would take a very long time. At the very least, an I term is required to eliminate the offset created by the P term.

Integral Control (Automatic Reset), I

The I term on the BW500 is used to increase or reduce the amount of control output to eliminate the offset caused by the P term. The I term acts on the *accumulation* of the error over small increments of time. As the process reaches setpoint and the error becomes small, the effect of the I term decreases. A higher I term makes the BW500 faster to react to changes, but can also make it less stable.

- allowable input range: 0.000 to 2.000
- typical operating range: 0.100 to 0.300
- default value: 0.200

The P and I terms together can make a suitable control algorithm and for many applications, they work fine. However, if faster response to changes is desired, it is necessary to use larger P and I terms. Unfortunately, larger terms can make the system unstable. A derivative term is needed to influence the control output as the process variable approaches the set point.

Derivative Control (Pre-Act or Rate), *D*

The *D* term on the BW500 influences the control output based on changes in the magnitude and direction of the change in error. If there is a constant error, the *D* term has no effect. As the error gets larger, the *D* term combines with the *P* term to make the BW500 control output respond faster. When the error is getting smaller, the *D* term acts to reduce the amount of control output to help prevent overshooting the setpoint. In general, a higher *P* term will require a larger *D* term.

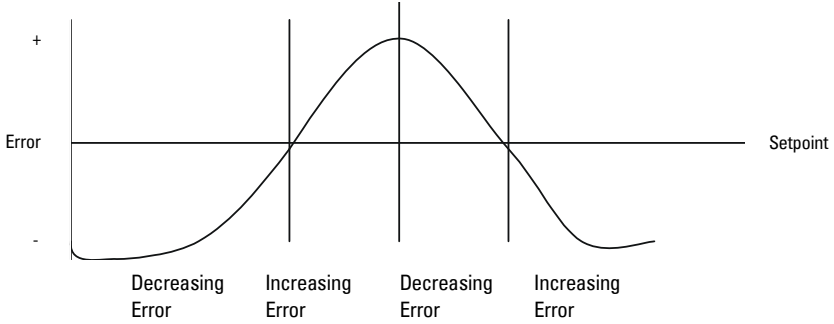

Direction of Proportional Action	↑	↓	↓	↑
Direction of Derivative Action	↓	↓	↑	↑

- allowable input range: 0.000 to 1.000
- typical operating range: 0.010 to 0.100
- default value: 0.050

The result of the derivative action is that it can make a system more responsive and more stable at the same time.

Feed Forward Control, *F*

On the BW500, the *F* term is used to adjust the control output based on a setpoint change. The use of this term can make the system reach the new setpoint faster. If the term is not used, the system responds using the *P*, *I* and *D* terms only. The difference between the new setpoint and the process variable is the error and the control algorithm responds to eliminate this new error.

When the *F* term is used and a new setpoint is entered, a proportion of the difference between the new setpoint and the process variable is automatically added on to the control output. This shifts the process variable closer to the new setpoint faster than using the *P*, *I* and *D* terms alone. This is done on a one time basis.

- allowable input range: 0.000 to 1.000
- typical operating range: 0.250 to 0.550
- default value: 0.300

The PID control function of the BW500 can be configured to operate in several modes.

- controller output: direct acting
- feedback: rate, load, or external
- control: local or remote (ratio) setpoint

PID Setup and Tuning

Proper tuning of the control PID terms is essential to system operation and optimum performance from the feeder. The recommended procedures for tuning the PID control terms at initial start-up are described in this section.

Initial Start-Up

Although the default values of the P, I, D, and F terms will suit the majority of applications, shearing weigh feeders in particular, some tuning will be necessary nonetheless.

There are several techniques and procedures for tuning conventional PID controllers, some work better depending upon the application. We recommend using "closed-loop cycling" for the BW500 integrator/controller for feed rate control. This technique focuses on tuning the P term first while disabling the I and D terms. This is followed by adding and tuning the I term, then the D term. To outline this procedure:

1. With the P term set to its default value of 0.400, disable the I, D, and F terms by setting them to 0.000.
2. Enter a feed rate setpoint that is 30% of the designed maximum flow rate.
3. Having applied the test weights or chain provided, start the feeder and observe the time it takes the feeder to reach setpoint, also observe the oscillation around setpoint.
4. Adjust the P term accordingly for consistent oscillation and error. Progressively decrease the P term value if there is too much oscillation and error. Likewise, increase the value if the error is not consistent and oscillating around the setpoint. Refer to figures 1, 2, and 3 below.

Figure 1

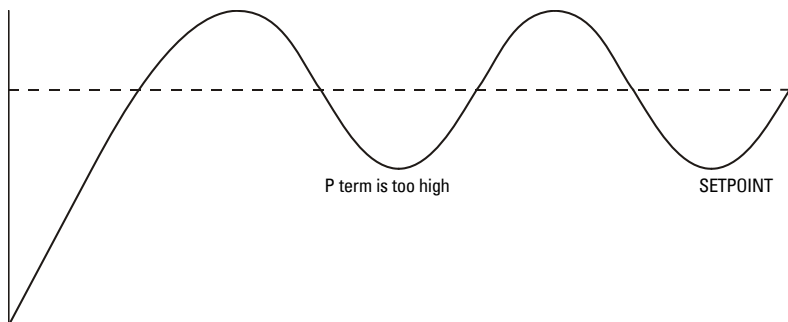

Figure 2

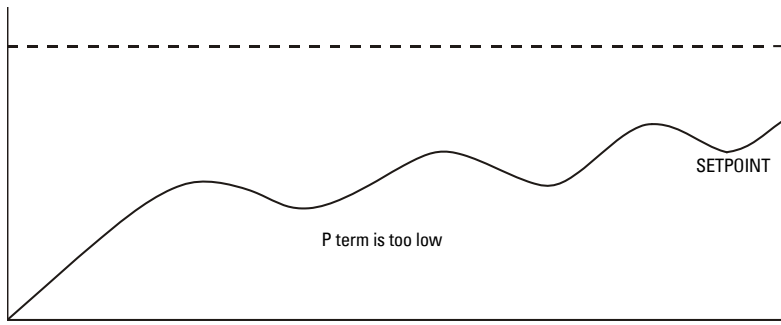
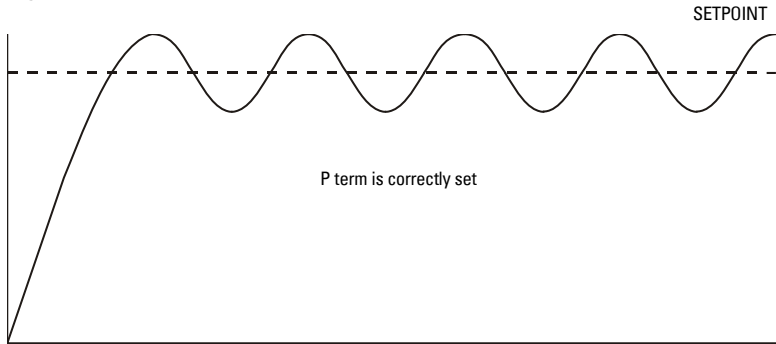

Figure 3



5. Once the P term value is set to give the control output of the BW500 consistent oscillation and the error is at its minimum, turn the feeder off.
6. The I term value can now be set. Begin by entering the default value of 0.2.
7. Restart the feeder (test weights or chains still applied) and feed rate setpoint entered.
8. Again observe the oscillation of the control output. Compare results to the figures 4,5 and 6 below.

Figure 4

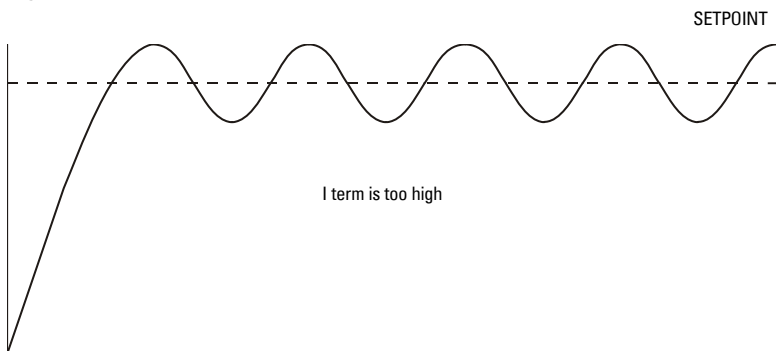

Figure 5

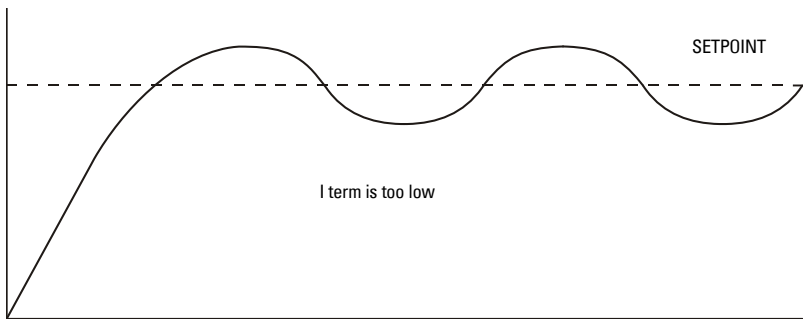
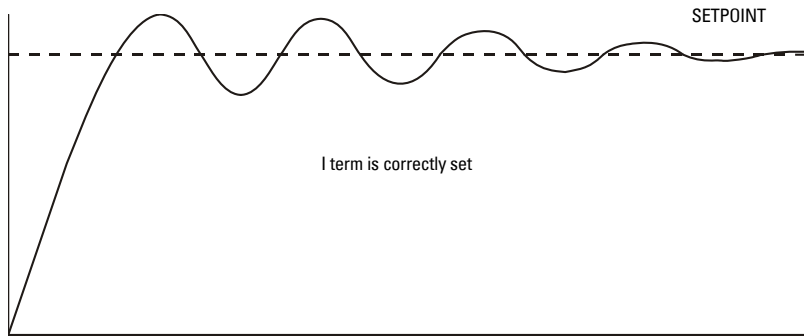

Figure 6



9. The D term is not critical in typical shearing type weigh feeder applications. The purpose of the D term is to anticipate where the process is heading by looking at the time, rate, and direction of change of the process variable. The D term becomes very useful in applications where the material control point is far away from the measuring point. An example of this would be a weigh belt or conveyor with a belt scale (constant speed) being fed from a pre-feeder some distance or more than a few seconds process time from the scale. A properly set D term will make the initial oscillations around the setpoint smaller, as in figure 6. A D term set too high induces high oscillations, as in figure 4. Omission of the D term, or set too low, shows no effect on the system.
10. The above closed loop cycling procedure allows ease in start up, but final adjustments may be necessary in actual process operation.

Programming

The BW500 is software ready, however the controller function must be specifically programmed in addition to programming of parameters P001 through P017.

The BW500 offers programming for two separate PID controls, 1 and 2. The controller being programmed is identified by the suffix to the parameter number. e.g. P400-01 indicates that PID for control system 1 is accessed.

Note: All programming should be done in the PID manual mode.

Access

P400-01 PID System	E	select 1-manual to program PID parameters
Select: 0-Off, 1-Manual, 2-Auto	0	

Off disables the PID parameter set, P401 to P418. They are not accessible.

Manual: the control output is the manual output P410.

Auto: engages the PID controller function. This can also be done using the  key.

Note:

For the mA output:

- mA output 2 (P201-02) is normally reserved for controller 1. The signal is output at terminals 1 and 2 on the mA I/O board.
- mA output 3 (P201-03) is normally reserved for controller 2. The signal is output at terminals 3 and 4 on the mA I/O board.

P201-02 mA Output Function	E	select the PID function
Select: 1-Rate, 2-Load, 3-Speed, 4-PID	1	

Note:

For the mA input:

- mA input 1 is an external signal normally reserved for controller 1. The signal is input at terminals 5 and 6 on the mA I/O board.
- mA input 2 is an external signal normally reserved for controller 2. The signal is input at terminals 7 and 8 on the mA I/O board.

P250-01 mA Input Range Select 1- 0 to 20, 2-4 to 20	E 2	select the appropriate range for the mA input signal
P255-01 mA Input Function Select: 0, 1-PID SP, 2-PID PV	E 0	assign either: 1: PID setpoint, or 2: process variable as the function of the mA input
P401-01 PID Update Time Readings between PID Updates	E 1	enter the value, e.g. nominal value of 1
P402 Process Variable Source 1-Rate, 2-Load, 3-mA In	E	select the source. Rate and load are internal values.
P405-01 Proportional Term Enter	E 0.40	enter the value for the proportional term, e.g. nominal value of 0.4
P406-01 Integral Term Select 1- 0 to 20, 2-4 to 20	E 0.2	enter the value for the integral term, e.g. nominal value of 0.2
P407-01 Derivative Term Enter	E 0.05	enter the value for the derivative term, e.g. nominal value of 0.05
P408-01 Feed Forward Term Enter	E 0.3	enter the value for the feed forward term, e.g. nominal value of 0.3
P410-01 Manual Mode Output Current Output Value	E 0	% value of output during manual operation, P400 = 1
P414-01 Setpoint Configuration 0-Local, 1mA In	E 0	selection of setpoint source: 0 = local (keypad or Dolphin Plus) 1 = mA input

Local: the setpoint is the value entered into P415

mA Input 1: the setpoint is the mA value on input 1, terminals 5 and 6 on the mA I/O board

mA Input 2: the setpoint is the mA value on input 2, terminals 7 and 8 on the mA I/O board

P415-01 Local Setpoint Value Enter Setpoint	E 0	enter the setpoint value in engineering units.
---	----------------------	--

Not applicable if P414 = 1

P416-01 External Setpoint	E	current setpoint value in engineering units, obtained from the mA input
Setpoint	0	

P418-01 Remote Setpoint Ratio	V	increase or decrease to scale input setpoint, if desired.
Enter % of Master Output	100.000	

P250-01 mA Input Range	E	select the appropriate range for the mA input signal
Select 1- 0 to 20, 2-4 to 20	2	

P255-01 mA Input Function	E	assign either: 1: PID setpoint, or 2: process variable as the function of the mA input
Select 0, 1-PID SP, 2-PID PV	0	

Note: The PID setpoint can be modified while in RUN mode using the up/down arrow keys.

Batching¹⁾

The batching process, as it relates to the BW500 operation, can be defined as the transfer of a predetermined quantity of material.

The process supports a count up operation (P560), in that the total (totalizer 5) begins at zero and increments up to the programmed setpoint (P564). A relay (RL1 through 5) programmed as the batch setpoint function (P100 = 8) is actuated when the material total reaches the setpoint. The relay contact acts as an interlock to the material feed to end the batch.

Another relay can be programmed as a pre-warn alarm (P100 = 7), to alert the process that batch end is near. The relay is actuated when the material total reaches the pre-warn setpoint (P567) at some practical value below the batch setpoint. The pre-warn function is enabled/disabled from the batch process through P566.

For batch operations, the following must be addressed:

- connections
- programming
- operation

¹⁾ Not available on the BW500/L

Connections

Typical Ladder Logic

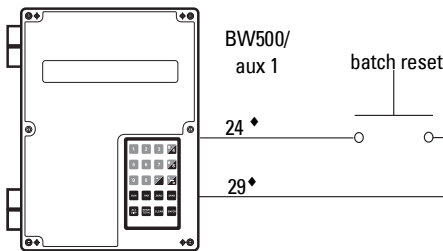
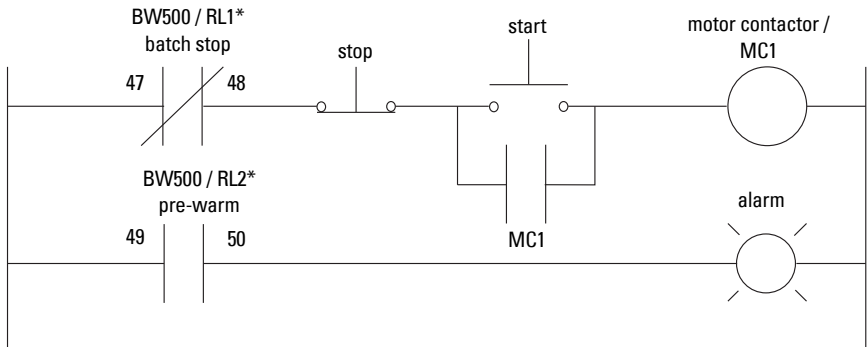

* Typical relay assignment. Relays 1-5 are available for batch setpoint or pre-warm alarm function.

◆ Typical auxiliary input assignment. Inputs 1-5 are available for batch reset.

Programming

The pre-warn function is optional.

The setpoint associated with the pre-warm relay is entered in P564, batch setpoint.

The setpoint associated with the batch relay is entered in P567, batch pre-warn setpoint.

Batch Operation	
access P100, relay function	select relay (1 – 5)
	select function 7, pre-warn
Access P560 Batch Mode Control	select 1, enable batch operation
<i>if batch pre-warn is selected</i> access P567, batch pre-warn setpoint	enter the pre-warn total
Access P568 Batch Pre-act	set to OFF (0) or AUTO (1) or manual (2)
Relays	
Access P100, Relay Function	select relay (1 – 5)
	select function 7, Pre-Warn

Operation

Once the BW500 relays are connected to the process logic, and it is programmed, the BW500 is ready for totalizing the batch and stopping the process when the batch setpoint is reached. The batch operation: start, pause, resume, and cancel are controlled externally by the process control (e.g. PLC)

Place the unit in the **RUN** mode.

Press ALT DISP until the batch screen is displayed.

Rate	0.00 kg/h	SP:	20.000
Batch	0.00 kg		

e.g. relay 1 is programmed for pre-warn, P100-1=7

Start running the batch.

The display will show the rate of material flow and the batch total, as well as the batch setpoint. If pre-warn is used, relay contact is open.



When the batch total reaches the pre-warn setpoint, if programmed, the alarm event is removed and the assigned relay contact is closed.

Rate	123.4 kg/h	SP:	20.000
Batch	17.00 kg		ALM 1

The process continues, and when the batch total reaches the batch setpoint, the alarm event is displayed and the assigned relay is actuated (contact opened). Typically the relay contact would be integrated into the batch control logic to end the process.

Rate	123.4 kg/h		
Batch	20.00 kg		ALM 12

e.g. relay 2 is programmed for batch setpoint, P100-2=8

When the next batch is to be run, pressing  and then  on the local keypad, or providing a momentary contact closure across an auxiliary input (programmed as batch reset, P270 = 8), sets the alarm display and resets the batch total to zero, and the relay contact to its closed state.

Rate	0.00 kg/h	SP:	20.000
Batch	0.00 kg		

Note:

- The batch totalizer can be viewed as a read-only parameter (931-05), using single Parameter access through any programmed communication port.
- The batch setpoint can be modified in RUN mode using the up/down arrow keys.

Pre-act Function

If repetitive batches are being run, the pre-act function (P568) can be enabled to automatically trip the setpoint relay before or after the batch setpoint is reached to assure best batch accuracy.

Communications

The BW500 and BW500/L is an sophisticated belt scale integrator that can communicate status back to a SCADA system using a serial device such as radio modems, leased lines, or dial up modems.

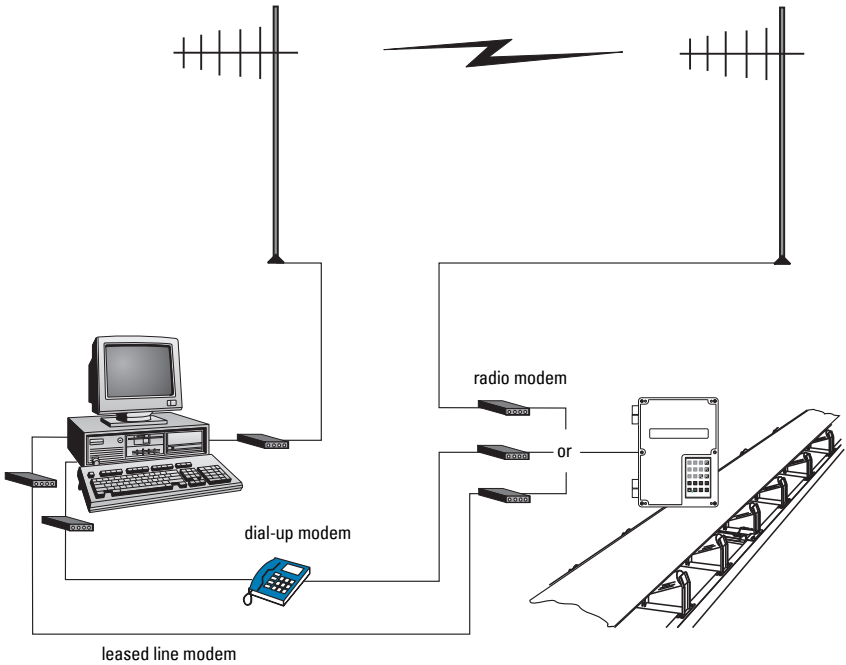

The BW500 and BW500/L supports two protocols: Dolphin and Modbus. Dolphin is a proprietary Siemens Milltronics protocol designed to be used with Dolphin Plus. Modbus is an industry standard protocol used by popular SCADA and HMI systems.

BW500 and BW500/L and SmartLinX®

In addition to three onboard communication ports, the BW500 and BW500/L is compatible with Siemens' SmartLinX® communication modules which provide an interface to popular industrial communication systems.

This section only describes the onboard communications. For more information on SmartLinX®, please consult the appropriate SmartLinX® manual.

Connection



WARNING: When a SmartLinX® card is installed and P799 = 1, the parameters that the SmartLinX® card is writing to the BW500 and BW500/L will be continuously updated. Therefore, if you connect a SmartLinX® card to the BW500, set P799 = 1 and not write anything to the SmartLinX® card, your setpoints will be 0.

There are three serial communication ports on the BW500 and BW500/L:

Port	Description
1	RS-232, Terminals 31 to 34
2	RS-485, terminals 41 to 46
3	RS-232, RJ-11 modular telephone jack

Refer to the *Installation* on page 9 for wiring diagrams specific to each port.

Wiring Guidelines

Improper wiring and choice of cables are the most common sources of communication problems. Listed below are some suggested guidelines:

- 15 meters (50 feet) for RS-232
- 1200 meters (4000 feet) for RS-485
- Ensure that communication cable is run separately from power and control cables (i.e. do not tie wrap your RS-232 cable to the power cable or have them in the same conduit).
- cable is shielded and connected to ground at one end only
- 24 AWG (minimum)
- follow proper grounding guidelines for all devices on the bus
- use good quality communication grade (shielded twisted pairs) cable that is recommended for RS-232.

Configuring Communication Ports

The BW500 and BW500/L communications ports are setup by a series of parameters (P770 – P789) which are indexed by port.

The communication parameters are indexed to the following:

Port	Description
1	RS-232, Terminals 31 to 33
2	RS-485, terminals 41 to 45
3	RS-232, RJ-11 modular telephone

f indicates the factory setting.

Note: Changes to these parameters are not effected until the power to the unit is turned off and then back on.

P770 Serial protocols

The communications protocol used between the BW500 and BW500/L and other devices for the selected port, ports 1 to 3 (P770-01 to –03).

The BW500 and BW500/L supports Siemens Milltronics' proprietary "Dolphin" data format, as well as the internationally recognized Modbus standard in both ASCII and RTU formats. It also supports direct connection of a printer.

The Siemens protocol is compatible with the Dolphin Plus configuration program. See the Siemens web site for information on this PC product (<http://www.siemens.com/processautomation>).

The Modbus protocol is an open standard developed by AEG Schneider Automation Inc. Specifications are available from their web site (<http://www.modicon.com/>).

Other protocols are available with optional SmartLinx[®] cards.

Values

0 ^f (01 and 02)	communications disabled
1 ^f (03)	Siemens Milltronics "Dolphin" protocol
2	Modbus ASCII slave serial protocol
3	Modbus RTU slave serial protocol
4	printer

Note: BW500 and BW500/L must be in **RUN** mode to allow for the print operation.

P771 Protocol address

Note: Applicable only to ports programmed for Modbus RTU or Modbus ASCII (P770).

The unique identifier of the BW500 and BW500/L on the network for the selected port, ports 1 to 3 (P771-01 to -03).

For devices connected with the Siemens Milltronics protocol this parameter is ignored.

For devices connected with a serial Modbus protocol this parameter is a number from 1-247. It is up to the network administrator to ensure that all devices on the network have unique addresses.

Do not use the value "0" for Modbus communications as this is the broadcast address and is inappropriate for a slave device.

Values

0 to 9999 ($f=1$)

P772 Baud Rate

The communication rate with the master device for the selected port, ports 1 to 3 (P772-01 to -03).

The baud rate chosen should reflect the speed of the connected hardware and protocol used.

Values

1^f ($f=01$ and 02)	4800 baud
2	9600 baud
3^f ($f=03$)	19,200 baud

P773 Parity

The serial port parity for the selected port, ports 1 to 3 (P773-01 to -03).

Ensure that the communications parameters are identical between the BW500 and BW500/L and all connected devices.

For example many modems default to N-8-1 which is: No parity, 8 data bits, and 1 stop bit.

Values

0^f	none
1	even
2	odd

P774 Data bits

The number of data bits per character for the selected port, ports 1 to 3 (P774-01 to -03):

Protocol	P744 Value
Modbus RTU	8
Modbus ASCII	7 or 8
Dolphin Plus	7 or 8

Note: If using port 2, 8 data bits must be used.

Values

5 to 8 ($f=8$)

P775 Stop bits

The number of bits between the data bits for the selected port, ports 1 to 3 (P775-01 to -03).

Values

1 or 2 ($f=1$)

P778 Modem attached

Sets port 1 (P778-01) to use an external modem.

Any connected modem must be set up to auto-answer incoming calls. The BW500 and BW500/L does not automatically configure the modem.

Autobaud (enabled by P778=1)

When the BW500 and BW500/L is powered up or the P779 Modem Inactivity Timeout expires three carriage returns are sent to the modem to allow it to set its serial connection to P772 Baud Rate.

If a connection is made with the modem at a different baud rate the BW500 and BW500/L will attempt to use that rate instead of the P772 value. For troubleshooting purposes the baud rate on the modem can be hard-coded to the rate set on the BW500 and BW500/L. See your modem documentation for information on fixing the baud rate.

Values

0^f no modem connected
1 modem connected

P779 Modem idle time

Sets the time in seconds that the BW500 and BW500/L will keep the modem connected even though no activity is happening.

To use this parameter ensure that P778=1.

This parameter allows for reconnection to the BW500 and BW500/L unit after an unexpected disconnect. Ensure that the value is low enough to avoid unnecessary delays when an unexpected disconnect occurs but long enough to avoid timeout while you are still legitimately connected.

Hanging Up

If the line is idle and the P779 Modem Inactivity Timeout expires then the modem is directed to hang up the line. This is done with the Hayes commands:

- two second delay
- +++
- two second delay
- ATH

Ensure that P779 is set longer than the standard polling time of the connected master device.

0 disables the inactivity timer.

Values

0-9999: 0 ($f=1$)

P780 RS-232 Transmission interval

Note: Applicable only to ports programmed for printer communication (P770).

Sets the interval between transmissions to be applied to the selected port, ports 1 to 3 (P780-01 to -03).

Enter the period in minutes ($f=0$)

P781 Data message

Note: Applicable only to ports programmed for printer communication (P770).

Sets the data message to be delivered via the selected port, ports 1 to 3 (P781-01 to -03).

All messages and printouts include time and date²⁾.

Entry:

0^f = no message

1 = rate

2 = total¹⁾

3 = load

4 = speed

5 = rate, total¹⁾, load and speed

6 = rate and total¹⁾

7 = batching²⁾

8 = rate and speed

9 = quick start parameters (P001 – P017)

10 = all parameters

P799 Communications Control

Assigns programming control either locally through the keypad or Dolphin Plus (P770 = 1), or remotely through Modbus protocol (P770 = 2 or 3) or SmartLinX[®].

Entry:

0 = local

1 = remote



WARNING: When a SmartLinX[®] card is installed and P799 = 1, the parameters that the SmartLinX[®] card is writing to the BW500 and BW500/L will be continuously updated. Therefore, if you connect a SmartLinX[®] card to the BW500 and BW500/L, set P799 = 1 and not write anything to the SmartLinX[®] card, your setpoints will be 0.

1) Totalizer 1 and/or 2 as set by P647, Totalizer Display.

2) Not available with BW500/L

Dolphin Protocol

The protocol is available on all communications ports on all units. This protocol is not available for third party use.

The primary use of this protocol is to connect the BW500 and BW500/L to Siemens Milltronics' Dolphin Plus configuration software.

Dolphin Plus Screen Shot

The screenshot shows the 'Milltronics Dolphin Plus - BW500' application window. The title bar includes standard window controls. The menu bar contains: File, Connection, Instrument Data, Options, Quit, Help. The toolbar has icons for file operations and help. The main window has a tabbed interface with the following tabs: Linearization, Totalization, Communication, Test, More Test, Install, Record, Security, Basic Setup, Display, mA O/P, Relay/Alarm, Load Cell Balancing, Calibration. The 'Display' tab is active, showing a list of parameters with their values:

Parameter	Value
Design Rate	4.99
Design Speed	2.07
Speed Constant	1.7300
Belt Length	32.456
Test Load	234

Callout boxes provide the following information:

- tabs show groups of parameters**: Points to the tabbed interface.
- Parameters have roll-overs which show number**: Points to the 'kilograms per hour (kg/h)' dropdown menu.
- Parameters can be tracked while the BW500 and BW500/L is running**: Points to the parameter list.
- The attached device can be programmed, debugged, and monitored from Dolphin Plus**: Points to the overall software interface.
- The status bar informs you of program actions and data transfer status**: Points to the bottom status bar.

The status bar at the bottom shows the time '10:35 AM', a traffic light icon, and a progress indicator.

Modbus RTU/ASCII Protocol

Modbus is an industry standard protocol owned by Schneider Automation Inc.¹⁾ and is used throughout process control industries for communication between devices. Modbus RTU and Modbus ASCII are both master-slave type protocols. BW500 and BW500/Ls Modbus is a slave unit.

BW500 and BW500/L supports both the RTU and ASCII version of Modbus and attempts to automatically detect the type when a connection is made.

Note:

- host should wait at least 500 ms between a message polls to the BW500 and BW500/L
- for Modbus RTU, the host should wait at least 1000 ms for a response from the BW500 and BW500/L. In Modbus ASCII mode the suggested timeout is 1500 ms.

A brief description of Modbus RTU and Modbus ASCII is given in this manual. For a full description of the Modbus protocol, contact your local Schneider representative. Also you may try their web site at:

<http://www.modicon.com>

At the time of publication of this manual, the Modbus Protocol was located under products / technical publications / communications products / Modbus protocol.

Note: Siemens does not own the Modbus RTU protocol. All information regarding that protocol is subject to change without notice.

How Modbus Works

As mentioned above, Modbus is a master-slave type protocol. This can also be referred to as a query-response protocol. What both of these terms mean is that on the network, there is one master which requests information from multiple slave devices. The slave devices are not permitted to talk unless they have been asked for information. When responding, the slaves will either give the information that the master has requested or give an error code consisting of why it can not give the information or that it did not understand the request. Refer to *Error Handling* on page 109.

All BW500 and BW500/L information is mapped into the Modbus holding registers so that Modbus function code 03 can read from them and Modbus function code 06 and 16 can write to them.

¹⁾ Modicon is a registered trademark of Groupe Schneider.

Modbus RTU vs. ASCII

There are two main differences between Modbus RTU and Modbus ASCII. The first is that Modbus RTU encodes the message in 8-bit binary, while ASCII encodes the message in ASCII characters. Therefore, one byte of information would be encoded into 8 bits for RTU and into two ASCII characters for ASCII (which would be two 7-bit units). The second difference is that the error checking method is different (see below).

Modbus RTU has the advantage that it has a much greater data throughput than ASCII. Modbus ASCII has the advantage that it allows time intervals of up to one second to occur between characters without causing an error. Either protocol works with the BW500 and BW500/L.

Modbus Format

Note: When using a commercial Modbus driver all of the message details are handled for you.

To give you a better idea of how a Modbus message works, a master on network would send a message in a format similar to this:



Where:

Station address	the network address of the slave being accessed
Function Code	number that represent a Modbus command, either: 03 read function 06, 16 write functions
Information	depends on function code
Error Check	Cyclical Redundancy Check (CRC) for RTU and Longitudinal Redundancy Check (LRC) for ASCII

There is more to the frame than is described above, this is shown to give the user a general idea of what is going on. For a full description, refer to the Modbus specifications.

Modbus Register Map

The memory map of the BW500 and BW500/L occupies the Modbus holding registers (R40,001 and up).

The BW500 and BW500/L was designed to make it easy for users to get useful information via Modbus. The following chart gives an overview of the different sections.

Register Map for BW500 and BW500/L:

Map Legend	Description
Type:	Arbitrary classification of registers.
Description:	Brief description or title of associated register.
Start:	Provides the starting address for the register(s) where the parameter values are to be read from or written to.
Number R:	The number of registers required to read or write the complete parameter value. Where the number of registers (6) are addressed in incrementing sequence from the start register.
Parameter Values:	Refer to <i>Parameter Values</i> , page 105.
Read:	Identifies the read / write capability for the register being addressed.
Reference:	Provides reference documentation for the register being addressed.

Type	Description	Start	# R	Parameter Values	Read	Reference
Format	Format Word for 32 bit variables	40,062	1	0 - 1	r/w	see page 98
ID	Device Identifier	40,064	1	2	r	see page 98
Handshaking Area (Parameter Access)	Parameter	40,090	1	0-999	r/w	see page 98
	Primary Index	40,091	1	0 - 9	r/w	
	Secondary Index	40,092	1	0 - 9	r/w	
	Format Word	40,093	1	bit mapped	r/w	
	Read Value (word 1)	40,094	2	32 bits	r	
	Write Value (word 1)	40,096	2	32 bits	r/w	
Date and Time ^{a)}	YYYY	41,000	1	1996-2069	r/w	see P008 page 113 and page 100
	MM	41,001	1	1 - 12	r/w	
	DD	41,002	1	1 - 31	r/w	see P009 page 113 and page 100
	hh	41,003	1	00 - 23	r/w	
	mm	41,004	1	00 - 59	r/w	
	ss	41,005	1	00 - 59	r/w	
	Time Zone	41,006	1	-12 - 12	r/w	see P739 page 143

Type	Description	Start	# R	Parameter Values	Read	Reference
Process Values	Rate	41,010	2	32 bits	r	see page 101
	Load	41,012		32 bits	r	
	Speed	41,014	2	32 bits	r	
	Total 1	41,016	2	32 bits	r	
	Total 2	41,018	2	32 bits	r	
	Device State	41,020	1	bit mapped	r	see page 101
	Command Control	41,022	1	bit mapped	r/w	see page 102
	Multi-Span Selection	41,024	1	1 - 8	r/w	see page 50 and P365 on page 127
	Total 1 decimal places	41,025	1	1 - 3	r/w	see page 103
	Total 2 decimal places	41,026	1	1 - 3	r/w	see page 103
	PID 1 Setpoint ^{a)}	41,040	2	32 bits	r/w	see P415 page 130
	PID 2 Setpoint ^{a)}	41,042	2	32 bits	r/w	
	Batch Setpoint ^{a)}	41,044	2	32 bits	r/w	see P564 page 134
	Batch Prewarn Setpoint ^{a)}	41,046	2	32 bits	r/w	see P567 page 134
I/O	Discrete Input	41,070	1	bit mapped	r	see page 104
	Relay Outputs	41,080	1	bit mapped		
	mA Inputs ^{a)}	41,090	2	0000 - 20,000	r	
	mA Outputs	41,110	3 ^{b)}	0000 - 20,000	r	
Diagnostic	Diagnostic State	41,200	1	number code	r	see page 148
	P940, load cell A, index 1	41,201	2	32 bits	r	see page 146
	P940, load cell B, index 2	41,203	2	32 bits	r	see page 146
	P940, load cell C, index 3 ^{a)}	41,205	2	32 bits	r	see page 146
	P940, load cell D, index 4 ^{a)}	41,207	2	32 bits	r	see page 146
	P943, index 1	41,209	2	32 bits	r	see page 146
	P943, index 2 ^{a)}	41,211	2	32 bits	r	see page 146
	P943, index 3 ^{a)}	41,213	2	32 bits	r	see page 146
	P943, index 4	41,215	2	32 bits	r	see page 146
	P943, index 5	41,217	2	32 bits	r	see page 146
	P943, index 6 ^{a)}	41,219	2	32 bits	r	see page 146
P943, index 7 ^{a)}	41,221	2	32 bits	r	see page 146	
PID Tuning ^{a)}	PID 1 Proportional Term	41,400	2	32 bits	r/w	see P405 page 132
	PID 2 Proportional Term	41,402	2	32 bits	r/w	
	PID 1 Integral Term	41,404	2	32 bits	r/w	see P406 page 132
	PID 2 Integral Term	41,406	2	32 bits	r/w	
	PID 1 Derivative Term	41,408	2	32 bits	r/w	see P407 page 132
	PID 2 Derivative Term	41,410	2	32 bits	r/w	
	PID 1 Feed Forward Term	41,412	2	32 bits	r/w	see P408 page 132
	PID 2 Feed Forward Term	41,414	2	32 bits	r/w	
	PID 1 Remote Setpoint Ratio	41,416	2	32 bits	r/w	see P418 page 133
PID 2 Remote Setpoint Ratio	41,418	2	32 bits	r/w		

a) Not available with BW500/L

b) BW500/L has 1 output only

Modbus Register Map (cont'd)

Format (R40,062)

This value determines the format of all unsigned, double-register integers (UINT32), *except for those in the direct parameter access.*

0 indicates that the most significant byte (MSB) is given first

1 indicates that the least significant byte (LSB) is given first

For more information on this data format see page 105 and also *P742 Word Order Parameter* on page 143.

Device Identifier (R40,064)

This value identifies the Siemens Milltronics device type and is "2" for the BW500 and BW500/L.

Handshaking Area (Parameter Access)

Built into BW500 and BW500/L is an advanced handshaking area that can be used to read and write 32 bit parameters.

Mapping

Parameter Read and Write (40,090 – 40,095) is a series of six registers that are used for reading and writing parameter values to and from the BW500 and BW500/L. The first three registers are always unsigned integers representing parameters and index values. The second three registers are the format and value(s) of the parameter.

All parameters normally accessed through the hand-held programmer are available through these registers.:

Address	Description
40,090	Parameter (integer)
40,091	Primary Index (integer)
40,092	Secondary Index (integer)
40,093	Format word (bit mapped)
40,094	Read value, word 1
40,095	Read value, word 2
40,096	Write value, word 1
40,097	Write value, word 2

Reading Parameters

To read parameters through Modbus follow these steps:

1. Send the parameter, its primary index, and its secondary index (usually 0) and format to registers 40,090, to 40,093.
2. Wait until you can read the above values from the registers (40,090 to 40,093).
3. Read the value from registers 40,094 and 40,095.

Writing Parameters

To set parameters through Modbus follow these steps:

1. Send the parameter, its primary index, and its secondary index (usually 0) to registers 40,090, 40,091, and 40,092.
2. Write the value to registers 40,096 and 40,097
3. Write the desired format word to register 40,093 to enable the BW500 and BW500/L to interpret the value correctly.

Format Register:

Bits	Values	Description
1 - 8	0 - 2	Error Code
9 - 11	0 - 7	decimal offset
12	0/1	decimal shift, Right (0) or Left (1)
13	0/1	Numeric format: Fixed (0) or FLoat (1)
14	0/1	Read or Write of data, Read (0), Write (1)
15	0/1	Word order: Most Significant word first (0), Least Significant Word first (1)
16		Reserved

The bits listed above are in order from least to most significant:

16	15	14	13	12	11	10	9	8	7	6	5	4	3	2	1
----	----	----	----	----	----	----	---	---	---	---	---	---	---	---	---

e.g. to format the output value so that it is shown with two decimal places shifted to the left the format bits would look like this:

16	15	14	13	12	11	10	9	8	7	6	5	4	3	2	1
0	0	0	1	0	0	1	0	0	0	0	0	0	0	0	0



The value sent to the BW500 and BW500/L is 0001001000000000 binary or 4608 decimal. The value **4608** is sent as an integer to register 40,093 to format the output words 40,094 and 40,095 accordingly.

If the numeric data type is set for integer and the value contains decimal places they are ignored. In this situation use the decimal offset to ensure that you have an integer value and then write your code to recognize and handle the decimal offset. Bits 9 to 11 indicate the number of places by which the decimal is to be shifted. Bit 12 indicates the direction by which the decimal point is shifted, left or right. For example, if the decimal offset (value of bits 9 to 11) is '2' and the shift (value of bit 12 is) '0', then the decimal point is shifted two places to the right.

Error Codes

The error codes returned in the format area are 8-bit integers found in the lowest 8 bits of the format word. This allows for 256 potential error codes.

Currently the BW500 and BW500/L has two error codes available:

Values	Description
0	No error
1	Data not available as percent (available as units)
2-255	Reserved

Date and Time (R41,000 – 41,006)¹⁾

The date and time can be read or written in registers 41,000 to 41,006 as defined in the table above.

Example: If you are located in Toronto, Canada and would like to set the date and time to February 14, 1999, 1:30 p.m. and 42 seconds, you would write the following:

Bits	Values
R41,000	1999
R41,001	2
R41,002	14
R41,003	13
R41,004	30
R41,005	42
R41,006	-5

Note: The time zone register is used only as a reference and does not affect the operation of the BW500.

¹⁾ Not available with BW500/L.

Process Values (R41,010 – R41,048)

Rate, Load, Speed, and Total (R41,010 – R41,019)

The associated registers provide the readings of rate, load, and speed. Totalizer 1 and Totalizer 2 in engineering units as displayed in the local BW500 and BW500/L display.

Device State (41,020 – 41,020)

The Device State word is used to feed back the current operating state of the product. Each bit gives the state of different parts of the product, some mutually exclusive, others are not. The state should be checked to verify any device commands.

Bit #	Description	Bit Clear	Bit Set (1)
1	PID 1 Mode ^{a)}	Manual	Auto
2	PID 1 Freeze ^{a)}	No	Yes
3	PID 1 Setpoint Source ^{a)}	Local	Remote
4	PID 2 Mode ^{a)}	Manual	Auto
5	PID 2 Freeze ^{a)}	No	Yes
6	PID 2 Setpoint Source ^{a)}	Local	Remote
7	Zero	No	In progress
8	Span	No	In progress
9	-	-	-
10	-	-	-
11	-	-	-
12	-	-	-
13	Write Privileges	No	Yes
14	System Configured	Not Configured	Yes
15	Mode	Calibration Mode	RUN Mode
16	Totalizing	Not Totalizing	Totalizing

a) Not available with BW500/L.

Command Controls (41,022)

The command control word is used to control the unit. Each bit gives access to a command or state as if the operator was using the keypad.

Bits initiating a command (7-12) must change state to cause the command to begin. For example, to reset totalizer 1, Bit 9 must be set to 0, then changed to 1. It can stay set or clear for any period:

Bit #	Description	Bit Clear	Bit Set (1)
1	PID 1 Mode ^{a)}	Manual	Auto
2	PID 1 Freeze ^{a)}	No	Yes
3	PID 1 Setpoint Source ^{a)}	Local	Remote
4	PID 2 Mode ^{a)}	Manual	Auto
5	PID 2 Freeze ^{a)}	No	Yes
6	PID 2 Setpoint Source ^{a)}	Local	Remote
7	Zero	No change	Start
8	Span	No change	Start
9	Reset Totalizer 1	No change	Reset
10	Reset Totalizer 2	No change	Reset
11	Reset Batch Totalizer ^{a)}	No change	Reset
12	Print	-	Print
13	-	-	-
14	-	-	-
15	-	-	-
16	-	-	-

a) Not available with BW500/L.



WARNING: Before the BW500 and BW500/L can be commanded remotely, parameter P799 must be set for remote control.

Read/Write (R41,025 – R41,026) Total Decimal Places

Sets the number of decimal places (0-3) being read for Total 1, (words 41,016 and 41,017) and Total 2, (words 41,018 and 41,019).

With 3 decimal places, the largest value that can be read is 2,147,483.648.

With 2 decimal places, the largest value that can be read is 21,474,836.48.

With 1 or 0 decimal places, the largest value that can be read is 100,000,000.

Although the word registers are limited to reading a maximum value as indicated above for the defined number of decimal places, the overflow bits of Instrument_Status2 (Word 31) will only reflect an overflow condition (Bits 1 and 2 set to 1) when the decimal place is set to 2 or 3.

When set to 2 or 3, the word registers will stop accumulating at the indicated values however, the LUI will continue to totalize to a value of 100,000,000. Should this condition exist, prior to resetting the totalizer registers, be sure to observe and record the totalized value as displayed on the LUI. Not doing this could cause a reporting discrepancy in expected material totals within the process.

Once the internal totalizer registers realize a value of 100,000,000, the internal registers will perform a rollover, causing the display of the LUI to start from a value of 0. This will also cause the Instrument_Status2 word bits to reset to 0.

Example: R41,025

Bits 0 and 1 are used to indicate the number of decimal places being read in Total 1: words 7 and 8.

Bit 15 is used to indicate if the decimal place is too large to read the total value correctly.

If three decimal places are being read in Total 1:

Bits	15	14	13	12	11	10	9	8	7	6	5	4	3	2	1	0
	0	0	1	0	0	1	0	0	0	0	0	0	0	0	1	1

If three decimal places are being read in Total 1, and the value is too large to be read with three decimal places:

Bits	15	14	13	12	11	10	9	8	7	6	5	4	3	2	1	0
	1	0	1	0	0	1	0	0	0	0	0	0	0	0	1	1

I/O (R41,070 – 41,116)

The BW500 provides I/O in the form of:

- discrete inputs
- relay outputs
- mA inputs¹⁾
- mA outputs¹⁾

For the I/O, the assigned registers represent the logic status (e.g. open or closed) of the I/O as configured. Discrete inputs are configured via P270, auxiliary input function; while relay outputs are configured via P100, relay function.

The I/O are mapped into the respective input and output registers, R41,070 and R41,080, as follows:

R41,070		R41,080	
Input	Bit	Output	Bit
1	1	1	1
2	2	2	2
3	3	3	3
4	4	4	4
5	5	5	5

For the mA I/O, the assigned registers represent the mA level (e.g. 0 to 20 mA) of the I/O as registered in P911 and P914, mA output test (output value) and mA input value.

The mA I/O are mapped into the respective input and output registers:

Input	Register	Output	Register
1	R41,090	1	R41,110
2	R41,091	2	R41,111
		3	R41,112

For 0 to 20 mA I/O, the register value ranges from 0 to 20,000. For 4 to 20 mA I/O, the register value ranges from 4,000 to 20,000. If the 4 or 20 mA values have been trimmed, then the register value is adjusted accordingly; e.g. an I/O value of 22 mA would be registered as 22,000.

Diagnostic (R41,200)

Refer to *Troubleshooting* on page 148.

¹⁾ The standard BW500 provides only one mA output (0/4 – 20 mA). The inclusion of an optional mA I/O card provides two mA inputs (0/4 – 20 mA) and two additional mA outputs. The optional mA I/O card is not available with BW500/L

PID Tuning (R41,400 – 41,419)¹⁾

For BW500 set up for PID control, several registers have been provided for tuning. Refer to *PID Control* on page 71 and the associated parameters as listed in the register map.

Note: Before you can change any of the setpoints, P799 must be set for remote control.

Parameter Values

Bit Mapped

Bits are packed into registers in groups of 16 bits (1 word). In this manual we number the bits from 1 to 16, with bit 1 being the least significant bit and bit 16 referring to the most significant bit.

16	15	14	13	12	11	10	9	8	7	6	5	4	3	2	1
MSB								LSB							

32 Bit

Large numbers are put into unsigned 32 bit integers with a fixed decimal place of three. For example, a value of '7345' represents a value in the BW500 '7.345'. The default word order is that the first word is the most significant word (MSW) and the second word (register) is the least significant word (LSW).

For example, if we read R41,431 as a 32-bit, the 32 bits would look like the following:

R41,431			R41,432		
16	MSB	1	16	LSB	1
32	32-bit integer value (UNINT32)				1

The whole is read as a 32-bit integer.

The most significant byte (MSB) and least significant byte (LSB) can be reversed to accommodate some Modbus drivers. See Format Word for BW500 on page 98 for details.

¹⁾ Not available with BW500/L.

Text Messages

If a Siemens Milltronics device parameter returns a text message, that message is converted to a number and provided in the register. The numbers are shown in the table below:

Number	Text Message as Displayed on LCD
22222	invalid value
30000	off
30001	on
30002	====
30003	[] (parameter does not exist)
30004	err
30005	err1
30006	open
30007	shrt
30008	pass
30009	fail
30010	hold
30012	hi
30013	de
30014	en
-32768	value is less than -20,000
32767	value is greater than 20,000

Modems

The BW500 and BW500/L has been successfully connected to several different modems. In general, the Modbus protocol is a very modem friendly protocol. This section gives some general guidelines on modems and their connection. For detailed information, see the modem documentation.

Picking Modems

There are several different types of modems; dial-up, leased line, radio-link, fiber-optic, to name the most common.

Dial-up

uses a standard analog phone line and dials the number of the receiving modem.

Lease line

come in either 2 or 4 wire types and use special phone lines that are 'leased' from your phone company (or you) and do not require any dialing.

Radio-link

come in many different types, but all use radio frequencies for transmitting the information.

Fiber-optic

uses a fiber-optic line to connect the two modems.

Each type of modem and each model have various characteristics. Before purchasing the modem contact the modem manufacturer and ask if they have had experience using the modems with Modbus protocol with no flow control. If they have, ask them what settings were required.

Setting up the Modems

Modems can be configured using software, dip switches, jumpers, or a combination.

Dip switches are normally located at the back of the modem, jumpers are normally located on the motherboard and require that you remove the cover. Software normally requires you to use a standard terminal program and to connect to the RS-232 port on the modem and send special commands. The most popular command set is called the AT, or Hayes, command set.

Your modem manual should give details on how to configure it.

Example Setup

For a typical dial-up modem, try the following setup as a first attempt:

Master

Modem

- auto answer off (dip switch?)
- load factory default (dip switch?)
- no flow control (dip switch?)
- baud rate = 9600
- 10 data bits (probably the default)

Modbus RTU Software

- baud rate = 9600
- 8 bit
- no parity
- 1 stop bit
- dial prefix: ATDT
- Initialization command: ATE0Q0V1X05=0512=100
- Reset command: ATZ
- Hang-up command: ATH0
- Command response delay: 5 seconds
- Answer Delay: 30 seconds
- Inter-character delay: 55 ms

Slave

Modem

- auto answer on (dip switch?)
- load factory default (dip switch?)
- no flow control (dip switch?)
- baud rate = 9600
- 10 data bits (probably the default)

BW500 and BW500/L

- set P770, port 1, to the value 3 (Modbus RTU)
- set P771, port 1, to the value 1 (Network ID 1)
- set P772, port 1, to the value 3 (Baud rate of 9600)
- set P773, port 1, to the value 0 (No Parity)
- set P774, port 1, to the value 8 (8 Data Bits)
- set P775, port 1, to the value 1 (1 Stop Bit)
- set P778, port 1, to the value 1 (Communications through Modem)
- set P779, port 1, to the value 300 (Modem Inactivity of 300 seconds)

Note: Parameters are defined the in the Installation section (page 9).

Error Handling

Modbus Responses

When polled by a Modbus Master, a slave device will do one of the following:

1. **Not reply**
means something went wrong with the transmission of the message
2. **Echo back the command with the correct response**
is the normal response, (see the Modbus specifications for more details)
3. **Return an Exception Code**
reflects an error in the message

BW500 and BW500/L uses the following exception codes:

Code	Name	Meaning
01	Illegal Function	The function code received in the query is not an allowable action for the slave.
02	Illegal Data Address	The data address received in the query is not an allowable address for the slave.
03	Illegal Data Value	A value contained in the query data filed is not an allowable value of the slave.
04	Slave Device Failure	An unrecoverable error occurred while the slave was attempting to perform the requested action.
05	Acknowledge	The slave has accepted a request and is processing it, but a long duration of time is required.
06	Slave Device Busy	The slave is processing a long-duration program command.
08	Memory Parity Error	The slave attempted to read extended memory, but detected a parity error in the memory. Service may be required on the slave.

Error Handling

Errors can be divided up into two general sources:

1. an error in transmission
2. user tries to do something that is not a valid action

In the first case, the BW500 and BW500/L will not respond and let the master wait for a 'response time out' error, which will cause the master to re-send the message.

In the second case, it depends on what the user tries to do. Listed below are various actions and what the expected outcome is. In general, BW500 and BW500/L will not give an error to the user request.

- If the user reads an invalid parameter, the user will get a number back.
- If the user writes an invalid parameter (a non-existing parameter or a read only parameter), the value will be ignored and no error response will be made. However, the current value will not reflect the desired new value.
- If the user writes a read only register, then the value will be ignored and no error response will be made. However, the current value will not reflect the desired new value.
- If the user attempts to write one or more registers that are out of range, an exception response code 2 will be generated.
- If using an unsupported function code, undocumented results may occur. The user is encouraged not to do this.

Parameters

f indicates factory set value

P000 Security Lock

Locks out the program editor so that parameter values for P001 through P999 cannot be changed. This however, does not prevent the access to the parameters for viewing.

Programming is locked out if the value of P000 is other than 1954.

Entry:

1954 = unlocked^f

~~1954~~ = locked

Start Up (P001 to P017)

This is the minimum parameter programming required before attempting a calibration and successful entry into the **RUN** mode.

P001 Language

Selects the language for communication with the BW500 and BW500/L

Entry:

1 = English^f

2 = French

3 = German

4 = Spanish

5 = Italian

6 = Portuguese

7 = Russian

P002 Test Reference Selection

Selects the type of test reference used to represent a material load: weight, chain, or electronic.

weight: the weight that is supplied specific to the scale

chain: optional, sized specific to scale and conveyor

electronic: calibration based on automatic calculation of the mV span from the load cells

Entry:

1 = weight^f

2 = chain

3 = ECal

P008 Date¹⁾

Enter the current date in *yyyy-mm-dd* format:

yyyy = year

mm=month, 01 – 12

dd=day, 01 – 31

e.g. 1999-03-19 (March 19, 1999)

P009 Time¹⁾

Enter the current time in *hh-mm-ss* 24 hour format.

Where:

hh=hour

mm=minute

ss=second

P011 Design Rate

Specifies the design rate of material flow for the belt scale ($f= 0.00$).

Enter the design rate in the units selected (P005).

P014 Design Speed

Specifies the design speed for the conveyor belt ($f= 0.00$)

Speed units are:

feet/min if the imperial system of measurement has been selected, P004 = 1

metres/s if the metric system of measurement has been selected, P004 = 2

P015 Speed Constant

Set the speed constant for the speed sensor selected (P015-01 or 02)²⁾.

The value in P015-01 is used with the speed sensor frequency, to calculate the actual belt speed ($f= 0.000$).

The value in P015-02 is used for differential speed detection¹⁾.

Entry: If speed input is wired for constant speed (terminals 17/18 jumpered), value defaults to **jumpered**, and the second speed sensor is ignored.

If the speed input is connected to a speed sensor, press . P015 automatically jumps to P690. Refer to *P690* on page 139 for speed constant entry.

¹⁾ Not available with BW500/L.

²⁾ Index 02 is not available with BW500/L.

P016 Belt Length

The length of the conveyor belt (one belt revolution) ($f=0.000$)

Length units are:

feet: if the imperial system of measurement has been selected, P004 = 1

metres: if the metric system of measurement has been selected, P004 = 2

Enter the belt length.

P017 Test Load

The load to be referenced when performing a span ($f=0.00$).

Load units are:

lb/ft: if the imperial system of measurement has been selected, P004 = 1

kg/m: if the metric system of measurement has been selected, P004 = 2

The display indicates the test reference as selected by P002: 'weight', 'chain', or 'ECal' and the multispans number MS, 1-8¹⁾.

Enter the test load value.

In the case of weight, pressing enter at P017 invokes P680 for data entry.

In the case of ECal, pressing enter at P017 invokes P693 for data entry. ECal sets the value for P017 at 100% of design load (P952).

In the case of chain, pressing enter at P017 allows direct entry of the load value stamped on the chain's name plate.

If P002 is set to 'weight' the test load parameter presents two options:

1) enter the load in weight/unit length

Set *P680 Test Load: Weight (Options)* on page 139 to '1-Enter Value', and then enter the desired value for P017

or

2) the mass and the weigh length.

Set *P680 Test Load: Weight (Options)* on page 139 to '2-Enter Data' and then enter the 'Total Mass of Test Weights' in P681, and the 'Average Idler Space' in P682.

Example:

3 standard MSI test weights, 1.2 meter idler spacing

Test Load = $\frac{24.6 \text{ kg (3x8.2 kg)}}{1.2 \text{ m}} = 20.5 \text{ kg/m}$

1) Multispans function is not available with BW500/L.

P018 Speed Adjust

This parameter allows adjustment to the speed constant for both speed sensors (P015-01 or P015-02)¹⁾. Initially, this parameter displays the dynamic speed of the belt. If the displayed speed is not equal to the actual speed, enter the actual belt speed ($f=0.00$).

For speed sensor applications, the value of P015 is automatically adjusted.

For constant speed (terminals 17/18 jumpered) the value of P014 is automatically adjusted.

P019 Manual Span Adjust

Provides a means for adjustment to the span calibration ($f=0$)

The adjustment value is determined by performing material tests and is subsequently entered either as a calculation of % change into P598, or as the weight of the material test.

Entry:

1 = % change

2 = material test

Refer to *Recalibration* on page 41.

P022 Minimum Speed Frequency

Sets the minimum frequency that the speed sensor can reliably read. Signals at low frequencies are erratic, adversely affecting the performance of the weighing system.

Entry:

1 = 1 Hz (at 1 Hz, it takes 1 s before defaulting to 0 speed)

2 = 2 Hz¹⁾ (at 2 Hz, it takes 0.5 s before defaulting to 0 speed)

¹⁾ Not available with BW500/L

P080 Display Damping

P080-01	Rate
P080-02	Load
P080-03	Speed

Sets the speed of response to which the displayed readings (rate, load, and speed), and outputs (alarm and mA¹) react to change.

Refer to *Operation* on page 63.

Note: Effect of damping (P080-01) on mA output can be overridden by mA output damping (P220).

The higher the damping value, the slower the response.

Enter damping value, range 0.000^f– 999

P081 Display Scroll Mode

The **RUN** displays are scrolled either manually by pressing ALT DISP if the scroll mode is set to off, or automatically if the mode is set to on.

Entry:

0^f = OFF

1 = ON

Relay/Alarm Function (P100 - P117)

Note: BW500 has 5 programmable relays and BW500/L has 2

These parameters are specific to the use of the relay/alarm function. Refer to *Operation* on page 63.

¹) Damping is not applicable to the mA output if programmed for PID function (P201 = 4).

P100 Relay Function

Sets the relay function for the relay selected; BW500: relays 1 to 5 (P100 -01 to -05), BW500/L: relays 1 and 2 (P100 - 01, 02)

Note:

- To reset the Diagnostics relay, the BW500 and BW500/L must be cycled between **PROGRAM** and **RUN** mode
- To reset the Batch relays, the Batch totalizer must be reset.

Entry:

0 = OFF ^f

1 = rate

2 = load

3 = speed

4 = diagnostic¹⁾

5 = PID-01 setpoint deviation^{1) 2)}

6 = PID-02 setpoint deviation^{1) 2)}

7 = pre-warm^{1) 3)}

8 = setpoint^{1) 3)}

9 = online calibration^{1) 4)}

10 = differential speed detection^{1) 5)}

11 = certification rate alarm (high alarm preset to 100%, low alarm preset to 20 %)⁶⁾

P101 High Alarm / Deviation Alarm

High Alarm (f = 100)

For relay functions, P100 = 1, 2, and 3, this parameter sets the high alarm setpoint for the relay selected; BW500: relays 1 to 5 (P100 -01 to -05); BW500/L: relays 1 and 2 (P100 -01 to -02).

Enter the value in % of full scale.

Deviation Alarm (f = 10)¹⁾

For relay functions, P100 = 5 and 6, this parameter sets the deviation setpoint for the relay selected; relays 1 to 5 (P100 -01 to -05).

Enter the value in % of setpoint.

¹⁾ Not available with BW500/L

²⁾ Valid only if PID system (P400) is enabled

³⁾ Valid only if batch function (P560) is enabled

⁴⁾ Valid only if online calibration (P355) is enabled

⁵⁾ Valid only if Aux. input (P270) = 16 (differential speed detection)

⁶⁾ When selected parameters P101 and P102 are locked

Differential Speed (f = 110)¹⁾

For differential speed functions, P100 = 10, this parameter sets the high alarm setpoint for the relay selected; relays 1 to 5 (P100 -01 to -05).

P102 Low Alarm

Sets the low alarm setpoint for relay selected, BW500: relays 1 to 5 (P100 – 01 to – 05), BW500/L: relays 1 and 2 (P100 – 01 to – 02) (f=20).

Enter the value in % of full scale

Note: Not applicable if P100 = 4, 5, 6, 7, or 8.

Differential Speed (f = 90)¹⁾

For differential speed functions, P100 = 10, this parameter sets the low alarm setpoint for the relay selected; BW500: relays 1 to 5 (P100 -01 to -05).

P107 Relay Alarms

Sets the alarm mode for the relay selected; BW500: relays 1 to 5 (P100 -01 to -05); BW500/L: relays 1 and 2 (P100 -01 to -02).

Entry:

- 1 = high and low ^f
- 2 = high only
- 3 = low only

Note: Not applicable if P100 = 4, 5, 6, 7, or 8.

P117 Relay Dead Band

Sets the dead band for the relay selected; BW500: relays 1 to 5 (P100 -01 to -05); BW500/L: relays 1 and 2 (P100 -01 to -02). The dead band prevents relay chatter due to fluctuations at the high or low setpoint (f= 3.0).

Enter the value in % of full scale, or for deviation alarm enter % of setpoint, range is 1 to 10 %.

Note: Not applicable if P100 = 4, 7, or 8.

¹⁾ Not available with the BW500/L.

P118 Relay Logic

Sets the logic applied to relays to determine their open or closed state.

Power Failure

The relays on the BW500 default to normally open under power loss.

Normal Operation

In software, all relays are programmed the same way; with **ON** setpoints always indicating relay action. This parameter allows the reversal of the operation. Normally, P118 = 2 for each relay.

Reverse Operation

When P118 = 3, the operation of the indexed relay is reverse from normal.

Values

P118	Logic	Relay
2	positive logic	normally closed ^f
3	negative logic	normally open

P119 Override

This function allows the user to simulate an alarm condition: ON or OFF, which will override normal operation until P119 setting is returned to normal.

Values

P119	Condition	Display (alarm field)
0	normal	normal
1	alarm on	ALM #
2	alarm off	blank

mA I/O Parameters (P200 - P220)

These parameters are specific to the use of the mA output. Refer to *mA Output* on page 66 for details.

- mA output 1 is physically located at terminals 21/22 on the main board
- mA outputs 2 and 3, and inputs 1 and 2 are physically located on the optional mA I/O board which is mounted onto the main board.¹⁾

In the case of assigning mA input and output functions to PID control¹⁾, the following correlation exist:

	mA input	mA output
PID control 1	1	2
PID control 2	2	3

¹⁾ Not available with the BW500/L.

P200 mA Output Range

Sets the mA range for the output selected, outputs 1 to 3 (P200 - 01 to - 03)¹⁾.

Entry:

1 = 0 - 20 mA

2 = 4 - 20 mA^f

P201 mA Output Function

Assigns the mA output function for the output selected, outputs 1 to 3 (P201 - 01 to - 03)¹⁾

Entry:

1 = rate^f

2 = load

3 = speed

4 = PID control output^{2) 3)}

P204 mA Output Average

Sets the averaging period, in seconds, for the rate output for output 1 only.

The instantaneous mA values are averaged for the set period, and then the average value is output during the next period while a new average is being calculated.

Entry:

0 = OFF^f

1 – 999 = averaging period

P212 mA Output Minimum

Sets the minimum mA limit for the output selected, outputs 1 to 3 (P212 - 01 to - 03)¹⁾. The limit sets the lower mA range (0 or 4 mA) to a minimum output value ($f = 3.80$).

Enter limit value, range 0 - 22

P213 mA Output Maximum

Sets the maximum mA limit for the output selected, outputs 1 to 3 (P213 - 01 to - 03)¹⁾. The limit sets the upper mA range (20 mA) to a maximum output value ($f = 22.00$).

Enter limit value, range 0 - 22

1) BW500/L has one output, parameters will not present multiple indexes.

2) Not available with BW500/L.

3) Valid for outputs 2 and 3, only if PID system (P400) is enabled.

P214 4 mA Output Trim

Trims the 4 mA output level for the output selected, outputs 1 to 3 (P214 - 01 to - 03)¹⁾. The trim adjust the output to agree with a milliammeter or other external mA input device.

Scroll the trim value up or down

P215 20 mA Output Trim

Trims the 20 mA output level for the output selected, outputs 1 to 3 (P215 - 01 to - 03)¹⁾. The trim adjust the output to agree with a milliammeter or other external mA input device.

Scroll the trim value up or down

P220 mA Output Damping

Sets the damping for the output selected, outputs 1 to 3 (P220 - 01 to - 03)¹⁾. Damping sets the speed at which the mA output reacts to change. The greater the damping value, the slower the response. If the value is 0, the mA output assumes the damping set in P080 ($f = 0.00$).

Enter the damping value, range 0.001 – 999

P250 mA input range²⁾

Sets the mA range for the input selected, inputs 1 to 2 (P250 - 01 to - 02).

Entry:

1 = 0 - 20 mA

2 = 4 - 20 mA ^f

P255 mA Input Function²⁾

Assigns the mA input function for the input selected, inputs 1 to 2 (P255 - 01 to - 02)

Entry:

0 = OFF^f

1 = PID setpoint

2 = PID process variable

3 = Online calibration³⁾

4 = Moisture compensation

5 = Incline compensation

1) BW500/L has one output, parameters will not present multiple indexes.

2) Not available with BW500/L.

3) Valid only if Online Calibration is turned on, (P355 = 1).

P261 4 mA Input Trim¹⁾

Trims the 4 mA input level for the input selected, inputs 1 to 2 (P250 - 01 to - 02). The trim adjusts the input to agree with an external 4 mA source.

Follow the BW500 online instructions to trim the input

P262 20 mA Input Trim¹⁾

Trims the 20 mA input level for the input selected, inputs 1 to 2 (P250 - 01 to - 02). The trim adjusts the input to agree with an external 20 mA source.





Follow the BW500 online instructions to trim the input.

P270 Auxiliary Input Function

Selects the auxiliary input function for the input selected; inputs 1 to 5 (P270 - 01 to - 05).

Value	Function	Symbol	Description
0	off		
1	alternate display:		momentary closure of the input contact causes the RUN display to scroll to the next display.
2	reset totalizer 1:		momentary closure of the input contact resets the totalizer.
3	zero:		momentary closure of the input contact initiates a zero calibration.
4	span:		momentary closure of the input contact initiates a span calibration.
5	print:		momentary closure of the input contact sends a print request.
6 ^{a)}	multispan selection:		maintained closure state of the input contact(s) (up to 3) selects the multispan (P365).
8 ^{a)}	reset batch:		momentary closure of the input contact resets the batch totalizer to zero.
9 ^{a)}	PID freeze:		<u>off</u> closure suspends PID function in the auto mode <u>freeze</u> function in the auto mode and holds output at last value
10 ^{a)}	PID setpoint source:		remote local

¹⁾ Not available with BW500/L.

Value	Function	Symbol	Description
11 ^{a)}	PID mode:		auto manual
12	external alarm:		the input contacts status is sensed off
13	remote communication write:		keypad / Dolphin Plus write (program) enabled SmartLinx® / remote device write (program) enabled
14 ^{a)}	initiate online calibration:		momentary closure of the input contact initiates online calibration
15 ^{a)}	accept new online calibration span:		momentary closure of the input contact accepts the online calibration deviation
16 ^{a)}	auxiliary speed sensor		for differential speed detection

a) Not available with BW500/L.

Note: Before you can use Online Calibration, P100, P255, P355, P356, and P357 must be set up.

Entry:0 = OFF^f

1 = alternate display

2 = reset totalizer 1

3 = zero

4 = span

5 = print

6 = multispans selection^{1) 2)}7 = reserved²⁾8 = reset batch²⁾9 = PID freeze²⁾10 = PID setpoint source²⁾11 = PID mode²⁾

12 = external alarm

13 = remote communication write

14 = Initiate Online Calibration²⁾15 = Accept new online calibration span^{2) 3)}16 = Auxiliary speed sensor²⁾

multispans selection	Auxiliary Input	auxiliary input 2	auxiliary input 3
1	— —	— —	— —
2	— /—	— —	— —
3	— —	— /—	— —
4	— /—	— /—	— —
5	— —	— —	— /—
6	— /—	— —	— /—
7	— —	— /—	— /—
8	— /—	— /—	— /—

1) If the BW500 is programmed for multispans operation, the auxiliary input contact state determines the multispans number (equivalent to P365). Input 1 is reserved for multispans 1 and 2 selection. Input 2 is reserved for multispans 3 and 4 selection. Input 3 is reserved for multispans 5 to 8 selection.

2) Not available with BW500/L

3) Enter 1 (existing – ALT_DSP) to reject the new online calibration span.

If an attempt is made to select a multispan that has not been zero and span calibrated, the selection request is ignored.

Note:

- When performing a remote span, it will first perform a zero, then it will ask you to set up span test. Once loading is within $\pm 2\%$ of the design test weight, it will perform the span.
- For the print command to work, the BW500 and BW500/L must be in **RUN** mode.

Calibration Parameters (P295 – P360)

P295 Load Cell Balancing

Initiates an electronic balancing of the load cell input signals. Balancing is required for belt scale models of two, four, or six load cell design.

Refer to *Start Up* on page 28 for requirements and execution.

P341 Days Of Service

The cumulative days that the application device has been in service. The time is recorded once daily in a non-resettable counter. Periods of less than 24 hours. are not recorded, nor accumulated ($f=0$).

P350 Calibration Security

Provides additional security to the global lock (P000).

		zero	span	'Reset T'
entry:	0 = no additional security. ^f	Yes	Yes	Yes
	1 = in addition to P000 lock; no span.	Yes	No	Yes
	2 = in addition to P000; no zero, no span.	No	No	Yes
	3 = in addition to P000; no zero, no span, no totalizer 1 (T1) reset.	No	No	No

Online Calibration Options (P355 to P358)¹⁾

Note: Online calibration options must be enabled (P355 = 1) before they become available.

P355 Online Calibration Feature

Enables Online Calibration.

Entry:

0 = OFF^f

1 = ON

P356 Online Calibration Reference Weight

Enter the weigh bin reference weight, (in units selected in P005), range 0.000 to 99999 ($f=0.000$).

P357 Online Calibration Limits

Use to enter the weigh bin limit settings.

P357.1 MAX LIMIT, range 0.0 to 100.0 ($f=0\%$)

P357.2 HIGH LIMIT, range 0.0 to 100.0 ($f=0\%$)

P357.3 LOW LIMIT, range 0.0 to 100.0 ($f=0\%$)

P358 Online Calibration Activation

Initiates online calibration.

Entry:

0 = OFF^f

1 = ON

¹⁾ Not available with BW500/L.

P359 Factoring

Factoring is used as a method of calculating the value of the test load (P017) to a new test reference; either: weight, or chain. The task is performed only for the weight or chain relevant for the multispan selected, if applicable.

Entry:

1 = weight ($f=1$)

2 = chain

Refer to *Recalibration* on page 41 for execution of the factoring procedure.

Note: Totalization is halted during the factoring procedure, and resumed only upon return to the **RUN** mode.

P360 Calibration Duration

Sets the number of whole belt revolutions to be used during a zero or span calibration.

Enter number of belt revolutions, range 1 to 99. For belt scale applications 1 belt revolution or 2 minutes, whichever is longer; for weighfeeder applications 3 belt revolutions or 5 minutes, whichever is longer.

P365 Multispan¹⁾

Select the span reference to be applied for determination of rate and totalization.

Entry:

1 = multispan 1 (MS1), for product or condition A^f

2 = multispan 2 (MS2), for product or condition B

3 = multispan 3 (MS3), for product or condition C

4 = multispan 4 (MS4), for product or condition D

5 = multispan 5 (MS5), for product or condition E

6 = multispan 6 (MS6), for product or condition F

7 = multispan 7 (MS7), for product or condition G

8 = multispan 8 (MS8), for product or condition H

Refer to *Multispan* on page 50 and P270, Auxiliary Input Function (6) on page 122.

P367 Direct Zero Entry

Directly enters the zero reference count.

Direct entry is intended for use when replacing software or hardware and it is not convenient to perform an initial zero at that time ($f=0$).

Refer to *Recalibration* on page 41 for execution.

¹⁾ Not available with BW500/L.

P368 Direct Span Entry

Directly enters the span reference count for the span selected, span 1 to 8 (P368-01 to -08)¹⁾.

Direct entry is intended for use when replacing software or hardware and it is not convenient to perform an initial span at that time ($f=0$).

Refer to *Recalibration* on page 41 for execution.

P370 Zero Limit Deviation %

Sets the zero calibration deviation limit (\pm) from the last initial zero. If the accumulated deviation of successive zero calibrations exceeds the limit, the zero calibration is aborted ($f=12.5$).

Note: If the **legal for trade** certification switch has been set, the zero limit is $\pm 2\%$.

Enter the maximum allowable % deviation, range is 1 to 12.5 %.

P371 Auto Zero Initiation Upper Limit

This parameter sets maximum load on the belt as a percentage of design load at which the device will allow 'auto-zero' to run, min. 1.0%, max. 10.0%, default 2.0%.

When the certification switch is set this parameter will assume the default value (2.0%).

Note: material will not be totalized during auto zero calibrations.

P377 Initial Zero

Resets the initial zero.

The initial zero is the reference zero to which all subsequent operator initiated zero calibrations are compared in determining whether they have deviated beyond the zero limit (P370) ($f=1$).

Note: Refer to *Initial Zero* on page 46 for execution.

P388 Initial Span

Resets the initial span for the span selected, multispan 1 to 8 (P388-01 to -08)¹⁾.

¹⁾ BW500/L has one span entry possible, no indices will be presented.

The initial span is the reference to which all subsequent span calibrations are compared in determining whether they have deviated beyond an accumulated $\pm 12.5\%$ of the initial span ($f= 1$).

Note: Refer to *Initial Span* on page 49 for execution.

Linearization Parameters (P390 - P392)

These parameters are used to compensate for non-linear response of the weighing system to the BW500 and BW500/L. Refer to *Linearization* on page 59 for execution, and example on the use of these parameters.

Note: In the case of multispan operation, the linearizer is applied to all spans.

P390 Linearizer

Enables or disables the linearization function.

Entry:

0 = OFF^f

1 = ON

P391 Linearizer Load Points

Enters the load values, in units of P017, for the point selected, points 1 to 5 (P391-01 to -05) ($f= 0.00$, 150 % max.)

P392 Linearizer Compensation %

Enters the compensation value, in percent, for the point selected, point 1 to 5 (P392-01 to -05) ($f= 0.00$), range is -150 to 150 %.

P398-01 Moisture Content

Factors out moisture component of load, rate and total for all multispan selected. The factored values are meant to report the dry mean values of the material being conveyed ($f= 0.00$)

Enter the moisture content in % weight or mA Input Value¹⁾.

¹⁾ BW500/L will allow manual entry of a moisture content.

P398-02 Moisture Content¹⁾

Allows moisture content P398-01 to be scaled to maximum value.

Enter the moisture content in % weight (maximum value 20 mA).

P399 Incline Sensing

Factors out the varying vertical force components applied to the belt scale for all multispanns selected ($f=0.00$). The value is presented in degree angle ($0.0^\circ = \text{horizontal}$), with a range from -30 to 30° .

P399 can also be used for a constant angle if a mA input is not configured. Otherwise, P399 will contain the current value corresponding to the mA input.²⁾

Proportional Integral Derivative (PID) Control Parameters (P400 – P419)³⁾

Note:

- Changes to P401, P402, and P414 are not immediately effected while in auto mode. Change should be made in the manual mode and are effected upon return to the auto mode.
- The PID function does not control during any of the calibration functions (e.g. zero, span, factor, material test).

P400 PID System

Enables the selected PID system, systems 1 or 2 (P400 – 01 or – 02).

Entry:

0 = OFF^f
 1 = manual
 2 = auto

P401 PID Update Time

Sets the update time (P401 – 01 or -02) for the corresponding PID system (1 or 2).

Normally the controller is updated each time the process value is updated (every 300 ms). However in unstable or slow reacting systems the controller update can be programmed

¹⁾ Not available with BW500/L.

²⁾ BW500/L does not have mA inputs, only a fixed incline compensation value can be entered.

³⁾ Not available with BW500/L.

to update on a multiple of the process value update. A high value can introduce instability ($f=1$).

Entry:

1 = 300 ms

2 = 600 ms

3 = 900 ms, etc.

P402 PID Process Value Source

Determines the source of the process value (P402 – 01 or – 02) for the corresponding PID system (1 or 2)

The process value is the value that the controller is trying to match with the setpoint ($f= 1$)

Enter:

1 = rate^f

2 = load

3 = mA input 1

4 = mA input 2

P405 Proportional Term

Sets the proportional term (P405-01 or -02) for the corresponding PID system (1 or 2) ($f= 0.400$)

The proportional term is the proportional gain. A gain of 1 is equivalent to a proportional band of 100%.

The proportional band is the range of deviation from the setpoint that corresponds to the full range or the control output.

Enter the proportional term 0.000 to 2.000.

P406 Integral Term

Sets the integral term (P406-01 or -02) for the corresponding PID system (1 or 2) ($f= 0.200$)

Enter the integral term 0.000 to 2.000.

P407 Derivative Term

Sets the derivative term (P407-01 or -02) for the corresponding PID system (1 or 2) ($f = 0.050$)

Enter the derivative term 0.000 to 1.000.

P408 Feed Forward Term

Sets the feed forward term (P408-01 or -02) for the corresponding PID system (1 or 2) ($f= 0.300$)

Enter the feed forward term 0.000 to 1.000.

P410 Manual Mode Output

Displays the percentage output value (P410-01 or -02) for the corresponding PID system (1 or 2).

When the PID system is in manual, this is the value output, providing bumpless transfer when switching from manual to auto. When switching from auto to manual, this parameter is loaded with the current controlled value.

P414 Setpoint Configuration

Configures the setpoint (P414-01 or -02) for the corresponding PID system (1 or 2).

Determines the source for the PID's setpoint. If local, the setpoint value is entered into P415. The setpoint can be set from the mA input 1 or 2. The mA value is scaled to the full scale value of the process value (P402).

Entry:

0 = local^f

1 = mA input 1¹⁾

2 = mA input 2¹⁾

3 = % rate²⁾

4 = % load²⁾

P415 Local Set point Value

Sets the local set point (P415-01 / 02), in engineering units, for the corresponding PID system (1 or 2) when in auto mode. For the external process variable, the set point is shown in % ($f=0.000$).

Note: The PID setpoint can be modified while in RUN mode using the up/down arrow keys.

P416 External Setpoint

Displays the external setpoint (P416-01 / 02), in engineering units, for the corresponding PID system (1 or 2). For the external process variable, the setpoint is shown is %.

If the setpoint is external (P414 = 1 or 2), then this parameter displays the setpoint value that is being input, either mA input 1 or 2.

P418 Remote Setpoint Ratio

Sets the remote setpoint ratio (P418 -01/02) for the corresponding PID system (1 or 2) when P414 = 1 or 2 ($f=100$).

The remote setpoint ratio scales remote setpoint input by the set percentage. A value of 100 means that the setpoint is 100% of the mA input.

- 1) For PID-01, the setpoint source is mA input 1; for PID-02, the setpoint source is mA input 2.
- 2) Options 3 and 4 are only available if P402 has been set for an external process value source. For option 3, the setpoint will be the current rate value displayed as a percentage; for option 4 it will be the current load value displayed as a percentage.

P419 PID Freeze Option

Note: If the input speed frequency drops below 5 Hz, the PID control output freezes at its current value.

Enables or disables the PID freeze option described in the note above.

Entry:

0 = OFF

1 = ON^f

Batch Control (P560 – P568)¹⁾

The following parameters are specific to the use of the BW500 as a batch controller. P564-P568 is accessible only when Count Up (1) is selected.

P560 Batch Mode Control

Enables the batch control function. Batch control is count up.

Entry:

0 = OFF^f

1 = count up

P564 Batch Setpoint

Sets the batch total. When the amount of material delivered reaches this point, the batch relay contact opens (P100) to signal the end of the batch. ($f=0.000$)

Enter the setpoint of the units of weight selected (P005).

Note: The batch setpoint can be modified while in RUN mode using the up/down arrow keys.

P566 Batch Pre-Warn

Enables or disables the pre-warn function associated with batch control, warning that the batch is nearing completion.

Entry:

0 = OFF^f

1 = ON

P567 Batch Pre-Warn Setpoint

Sets the setpoint for the pre-warn function (P566). When the batch reaches the setpoint, the relay contact associated with the pre-warn function (P100) closes ($f=0.000$).

Enter setpoint in units of weight selected (P005).

¹⁾ Not available with the BW500/L

P568 Batch Pre-Act

Acts on the batch operation such that when the batch totalizer is reset, the batch total is compared to the setpoint (P564). The difference is then applied to pre-act on the setpoint for the next batch to improve the accuracy of the batch. The activity is internally limited to $\pm 10\%$ of the batch setpoint.

Entry:

0 = OFF^f

1 = Auto

2 = Manual

e.g. For Auto Batch Pre-Act

	1 st batch	2 nd batch	3 rd batch
setpoint	1000	1000	1000
pre-act	1000	950	960
total	1050	990	1000

P569 Manual Batch Pre-Act Amount

Enter a value to make the setpoint relay change state at a known value lower than the setpoint (P564). This allows the feeding system to empty with each batch. The value of the manual pre-Act entry is generally reflective of the material that is left in the feeding system.

Example:

Setpoint = 1000

Manual Pre-Act = 50

The setpoint relay will activate when the batch totalizer reaches 950.

P598 Span Adjust Percentage

Accessible only through manual span adjust (P019), when percent change (1) is selected.

Refer to *% Change* on page 42.

Totalization (P619 - P648)

The following parameters are specific to the use of the BW500 and BW500/L totalizers. See "Totalization" on page 68.

P619 Totaling Dropout

Sets the limit, in percent of design load, below which material rates are not totalized ($f=3.0$).

The value of **0** is reserved to allow both negative and positive totalization. Enter drop out value in % of design load, range is 0 to 25 %.

P620 Display Zero Dropout

Activates the limit as defined in P619 'Totalling Dropout', below which, the rate and/or load are set to 0.0.

- 01 = Rate
- 02 = Load

P621 mA Zero Dropout

Activates the limit as defined in P619 'Totalling Dropout', below which, the analog output, with respect to rate and load only, is set to 0.0.

Note:

- Valid only if P201 = 1 or 2
- BW500 has three mA outputs, BW500/L has one

P631 Totalizer Resolution

This parameter sets the resolution of the totalizer selected.

Totalizers are:

- 01 = totalizer 1
- 02 = totalizer 2
- 03 = verification totalizer
- 04 = material test totalizer
- 05 = batch totalizer¹⁾

Entry:

- 1 = 0.001 (one thousandth)
- 2 = 0.01 (one hundredth)
- 3 = 0.1 (one tenth)
- 4 = 1 (unit)^f
- 5 = 10 (x ten)
- 6 = 100 (x hundred)
- 7 = 1000 (x thousand)

¹⁾ Not available with the BW500/L

P634 Communication Totalizer Resolution

Used to set the number of fixed decimal places for Total 1 and Total 2 for SmartLinx or Modbus communication.

Entry:

P634 Index	Description	Value	# of decimal places
Primary Index 1	Total 1 for SmartLinx communication	3 ^f	3
		2	2
		1	1
		0	0
Primary Index 2	Total 2 for SmartLinx communication	3 ^f	3
		2	2
		1	1
		0	0

With 3 decimal places set, the largest readable value is 2, 147, 483.638. With 2 decimal places set, the largest readable value is 21, 474, 836.38. With 1 or 0 decimal places set, the largest readable value is 100, 000, 000.

Note: This parameter is only relevant if viewing the totalizer value using remote communications, such as SmartLinx or Modbus.

P635 Verification Totalizer

Enables a dedicated internal totalizer that totals the amount of material conveyed during a zero or span verification. It is used to verify the accuracy of the scale.

If a printer is connected to a port and the required programming is in order, a printout of the activity is automatically done on completion of the verification process.¹⁾

```

YYYY-MM-DD HH:MM:SS
Instrument ID#:
Start Total (T1):
End Total (T1):
Net Total (T1):
  
```

Entry:

0 = off, verification totalizer disabled^f

1 = do not total, verification totalizer is enabled, but main totalizers²⁾ are disabled

2 = add total, verification totalizer is enabled as well as main totalizers²⁾

¹⁾ Date and time are not available with the BW500/L

²⁾ Main totalizers consist of internal totalizers 1 and 2, and external totalizers 1 and 2.

P638 External Totalizer Resolution

Note:

- If the resolution selected would cause the totalizer to lag behind the count at 100% of design rate, the next possible resolution is automatically entered.
- External Totalizer output frequency must not exceed 13.33 Hz at 150% of design rate.

This parameter sets the resolution of the selected external totalizer.

Totalizers are:

P638-01, external totalizer 1 (T1), terminals 35/36

P638-02, external totalizer 2 (T2), terminals 38/39

Entry:

1 = 0.001 (one thousandth)

2 = 0.01 (one hundredth)

3 = 0.1 (one tenth)

4 = 1 (unit)^f

5 = 10 (x ten)

6 = 100 (x hundred)

7 = 1000 (x thousand)

P643 External Contact Closure

Sets the duration of the contact closure, in ms, for the external totalizer selected, totalizers 1 and 2 (P643-01 or -02) ($f=30$)

Permissible values are in 10 ms increments from 0. The value is automatically calculated upon entry of P1 (design rate) and P638 (totalizer 1 resolution, external) so that the duration of contact closure allows the transistor switch response to track the total, up to 150% of the design rate. The value can be changed to suit specific contact closure requirements, such as in the case of programmable logic controllers.

Note:

- If the duration selected causes the totalizer to lag behind the count rate, the next possible duration is automatically entered.
- External Totalizer output frequency must not exceed 13.33 Hz at 150% of design rate.

P647 Totalizer Display

Selects the totalizer combination to be displayed, either manually through the scroll display key or automatically by control of the display mode (P081).

Entry:

- 1 = totalizer 1^f
- 2 = totalizer 2
- 3 = totalizer 1 and 2

P648 Totalizer Reset, Internal

Manual reset of the selected internal totalizer when the entry is made ($f=0$).

Entry:

- 0 = no reset
- 1 = reset totalizer 2
- 2 = reset totalizers 1 and 2

Resetting the internal totalizers 1 and 2 resets the internal registers for external totalizers 1 and 2.

P680 Test Load: Weight (Options)

Selects the method by which the test load is entered into P017.

1 = enter value: returns to P017 for entry of the test load value. This value is calculated by the formula: Total Mass of the test weights/average idler spacing

Example:

3 test weights each weighing 8.2 kg, idler spacing before the scale is 1225 mm, the idler spacing after the scale is 1175 mm.

The average idler spacing is $1225 + 1175 / 2 = 1200$ mm or 1.2 m

Total mass of test weights/average idler spacing = $3 \times 8.2 \text{ kg} / 1.2 \text{ m} = 24.6 / 1.2 = 20.5 \text{ kg/m}$

2 = enter data: advances to P681 and P682 for entry of required data to automatically calculate and enter the test load into P017.

P681 Total Mass of Test Weights

For test load data entry (P680=2) this parameter is enabled for entry of the total mass of all of the test weights used for span calibration. The mass units are determined in P004 (imperial=1, metric=2).

P682 Average Idler Spacing

For test load data entry (P680=2) this parameter is enabled for entry of the average idler space before and after the scale. The length units are determined in P004 (imperial=1, metric=2).

P690 Speed Constant Entry

Selects the method by which the speed constant is entered, for both speed sensors (P690-01 or 02)¹⁾.

1 = calculated, this selection returns the program to appropriate P015 for entry of speed constant:

$$\frac{\text{speed sensor pulses per revolution}}{\text{pulley circumference (m or ft) / revolution}}$$

e.g:

MD-256 mounted on 6" Bend Pulley

$$\frac{256 \text{ pulses per revolution}}{0.478 \text{ meters per revolution}} = 534.694 \text{ pulses per meter or } 162.975 \text{ pulses per foot}$$

OR

2 = sensor data, the selection forwards the program to P691 and P692 for entry of the required sensor data for automatic calculation. The calculated value is automatically entered into P015-01 or 02.

P691 Drive Pulley Diameter

For speed constant entry (P690 =2), this parameter is enabled for entry of the drive pulley diameter (P691-01 or 02)¹⁾.

Enter the pulley diameter (units determined in P004).

P692 Pulses Per Sensor Revolution

For speed constant entry (P690 = 2), this parameter is enabled for entry of the pulses per revolution that the speed sensor delivers (P692-01 or 02)¹⁾.

Enter the pulses per revolution from the speed sensor nameplate.

¹⁾ BW500/L has only one speed input

ECal Parameters (P693 – P698)

Accessible only through P017 for ECal test reference. After Ecal completion, only a zero calibration is necessary to allow access to the **RUN** mode.

Note: ECal is not available on six load cell belt scales.

P693 Load Cell Capacity Units

Determines the units used for entering eCal data:

- 1 = kg
- 2 = lb
- 3 = Other (mV Span)¹⁾

P694 ECal Load Cell Capacity

Enters the load cell's weighing capacity for the selected cell ($f= 1.0$).

- 01 = load cell A
- 02 = load cell B
- 03 = load cell C²⁾
- 04 = load cell D²⁾

Enter the value in the units corresponding to the scale selection, e.g. in kg if P693 = 1, or lb. if P693 = 2 or 3.

P695 ECal Load Cell Sensitivity

Enters the load cell's sensitivity for the selected cell ($f= 1.0$).

- 01 = load cell A
- 02 = load cell B
- 03 = load cell C²⁾
- 04 = load cell D²⁾

Enter the value in mV/V obtained from load cell nameplate.

P696 ECal Load Cell Excitation

Determines the excitation applied to the load cells.

Nominally this value is 10 V. However, a measurement of the voltage at the load cell provides the most accurate entry.

Enter the load cell excitation in V DC.

- 1) In the case of other, software jumps to P699 since data entry P694 through P698 are not applicable if P693=4.
- 2) Not available with BW500/L

P697 ECal Idler Spacing

Enters the measured distance between the weighing idlers. Refer to the associated belt scale instruction manual ($f= 1.0$).

Distance units are:

feet: if the imperial system of measurement has been selected, P004 = 1

metres: if the metric system of measurement has been selected, P004 = 2

Enter the distance to three decimal points.

P698 ECal Conveyor Inclination

Enters the inclination or declination angle of the conveyor at the point where the belt scale is installed ($f= 0.0000$).

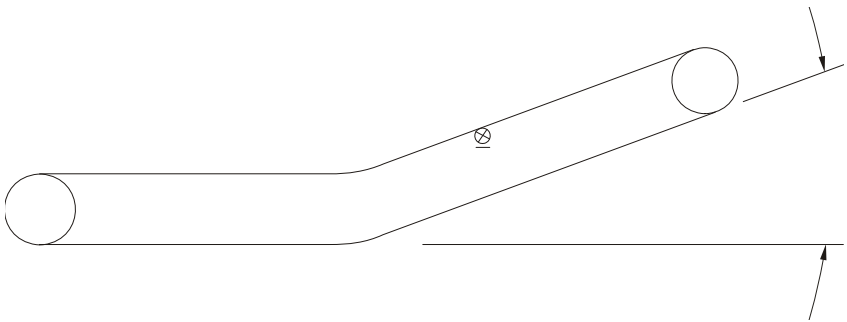

Enter the inclination in degrees.

Upon entry, display jumps to P017 to display the design load value as the test load.

P699 ECal mV Span

Enter the mV span corresponding to 0 to 100% full scale load.

Upon entry, display jumps to P017 to display the design load value as the test load.

P735 Back Light

Sets the intensity of the back light for the LCD ($f= 10$).

Entry:

0 = off

1 to 10 = low to high

P739 Time Zone

The offset from Greenwich mean time (GMT) of local time.

This parameter does not affect any timed events because all times are local. It can be accessed by a remote computer for synchronization purposes.

Enter local time zone –12 to 12

Communication (P740 - P799)

Note: Changes to these parameters are not effected until the power to the unit is turned off and then back on.

These parameters cover the various communications formats supported by the BW500 and BW500/L: serial printer, Dolphin Plus, SmartLinx[®], and Modbus.

P742 Word Order Parameter

Note: This parameter affects SmartLinx and Modbus communications

This value determines the format of all unsigned, double-register integers (UIN32), *except for those in the direct parameter access.*

Values	Description
0	^f most significant byte (MSB) is given first
1	least significant byte (LSB) is given first

P750 – P769 SmartLinx[®] Module Specific Parameters

These parameters are specific to the SmartLinx[®] module installed. Refer to the module documentation for a list and description of the specific parameter requirements.

P770 – P789 Local Port Parameters

These parameters are specific to programming of the BW500 and BW500/L communication ports. Refer to *Communications* on page 86 for a listing and description of these parameters.

SmartLinx Hardware Testing

These parameters are used to test and debug a SmartLinx card (if installed).

P790 Hardware Error

The results of ongoing hardware tests in the communications circuitry.

Values	Description
PASS	^f No errors
FAIL	Error occurred communicating with card; device will try to reinitialize communications with card. If message continues, record values in P791 and P792 and contact your local Siemens representative.
ERR1	No module installed, or module not supported; SmartLinX communications have been disabled

If **FAIL** or **ERR1** is displayed in P790 (Hardware Error), go to P791 (Hardware Error Code) and P792 (Hardware Error Count) for information about the error.

P791 Hardware Error Code

*Indicates the precise cause of **Fail** or **ERR1** condition from P790.*

Values	Description
0	^f No errors
Any other value	Error code; provide this code to your Siemens representative for troubleshooting

P792 Hardware Error Count

*A count that increments by 1 each time **Fail** is reported in P790 (Hardware Error).*

Values	Description
Range: 0 to 9999	Error count; provide this number to your Siemens representative for troubleshooting.

P794 SmartLinX Module Type

This parameter is used to identify the module type when SmartLinX is used. If you are not using SmartLinX, this parameter is not functional. Please see the associated SmartLinX instruction manual for a full description of this parameter.

P795 SmartLinX Protocol

This parameter is used to identify the protocol when SmartLinX is used. If you are not using SmartLinX, this parameter is not functional. Please see the associated SmartLinX instruction manual for a full description of this parameter.

If a SmartLinX module is not configured, P795 will have a value of either 255 or 0.

P799 Communications Control

Assigns programming control through the local keypad (or Dolphin Plus, P770 = 1), or through a Modbus protocol (P770 = 2 or 3)

Entry:

0 = local
1 = modbus

Test and Diagnostic (P900 - P951)

Note: These parameters are used for test and diagnostic purposes.

P900 Software Revision

Displays the EPROM (Flash ROM) software revision level.

P901 Memory Test

Tests the memory. Test is initiated by scrolling to the parameter or repeated by 'pressing enter'

Display:

PASS = normal
FAIL = consult Siemens.

P911 mA Output Test

Tests the mA output value for the output selected, outputs 1 to 3 (P911 -01 to -03)¹⁾

Displays the value from the previous measurement. A test value can be entered and the displayed value is transmitted to the output. Upon returning to the **RUN** mode, the parameter assumes the actual mA output level ($f=0$).

Use the  and  to scroll the value

P914 mA Input Value²⁾

Displays the current mA input value for the input selected, inputs 1 to 2 (P914 – 01 to -02).

Note: Not applicable if mA I/O board is not connected.

P918 Speed Input Frequency

Displays the frequency of the speed input signal in Hertz.

- 1) BW500/L has one output only
- 2) Not available for BW500/L

P931 Running Totalizer

- 1 = Total 1
- 2 = Total 2
- 3 = Verification Total
- 4 = Material Test Load
- 5 = Batch Total
- 6 = NTEP Total
- 7 = OCal Start Total
- 8 = OCal End Total

P940 Load Cell mV Signal Test

Displays the raw (unbalanced) mV signal input for the selected load cell, load cells A to D¹⁾ (P940 – 01 to – 04)

Range 0.00 - 60.00 mV.

P943 Load Cell A/D Reference

Displays the A/D reference value for the selected load cells. These values are affected by load cell balancing (P295).

Load cells are:

- 01 = A and B
- 02 = C and D²⁾
- 03 = A and B plus C and D²⁾
- 04 = A
- 05 = B
- 06 = C²⁾
- 07 = D²⁾

P948 Error Log

Displays a log of the last 25 error or alarm events (P948 – 01 to – 25) that have occurred. Event 01 is the current error.

Display:

0 = no error

= error code; refer to *Troubleshooting* on page 148

P950 Zero Register

Registers the number of zero calibrations that have been done since the last master reset ($f=0$).

- 1) Depending on the number of load cells selected by P003, not all load cells may be in use.
- 2) Not available for BW500/L

P951 Span Register

Registers the number of span calibrations for the span selected, span 1 to 8 (P951 - 01 to - 08), that have been done since the last master reset ($f= 0$).

P952 Design Load

Displays the value of the design load, which corresponds to the full scale value for alarm and mA output functions. The design load is calculated, based on the design rate and design speed ($f= 0.00$).

P999 Master Reset

Resets parameters and totalizers to their factory setting ($f= 0$).

Enter **9** to execute the reset.

Troubleshooting

Generally

1. First check to see that:
 - There is power at the unit
 - The LCD is showing something
 - The device can be programmed using the fixed keypad.
2. Then, check the wiring pin outs and verify that the connection is correct.
3. Next, go over the setup parameter P770 to P779 and verify that these values match the settings in the computer that you are using to communicate with it.
4. Finally, if you should check that the port you are using on the computer. Sometimes trying a different Modbus driver will solve the problem. An easy stand-alone driver called ModScan32, is available from Win-Tech at www.win-tech.com. We have found that this driver has been very useful to test communications.

Specifically

Q1: I tried to set a Siemens Milltronics device parameter, but the parameter remains unchanged.

- A1:**
- a. Try setting the parameter from the keypad. If it can't be set using the keypad, check the lock parameter (P000) and
 - b. Check to ensure that the SW1 (certification switch) is not in the certification position.

Error Codes

Error Code	Code Name	Message/Action
201	Error - Load Cell A & B	Reading between A & B > 15000, or no signal. Check wiring.
202	Error - Load Cell C & D	Reading between C & D > 15000, or no signal. Check wiring.
203	Err: 203	Memory failure test. Consult Siemens.
210	Remote Totalizer 1 exceeded	Increase resolution.
211	Remote Totalizer 2 exceeded	Increase resolution.
212	Maximum speed exceeded	Speed is > twice the design speed. Check design belt speed, actual belt speed, speed constant. Perform speed constant adjust (P018) if necessary.
213	Maximum rate exceeded	Rate is > three times the design rate. If no mechanical cause, check to see if re-rating the design rate is required.
220	Span too low	The span is based on the Design Load (P952). Ensure that the mV value representing the design load is greater than 1 mV. Typically the Test Load (P017) value is less than the value in P952; if it is greater than P952 check that the values entered in START UP parameters (P001 to P017) are entered correctly. Ensure proper test weight or chain is applied during span calibration.
221	Span out of range	Span deviation > 12.5%. Consider an initial span (P388). Refer to <i>Initial Span</i> on page 49.
222	Zero out of range	Zero deviation > minimum limit. Consider an initial zero (P377). Refer to <i>Initial Zero</i> on page 46.
223	Security Violation	An attempt to run command / calibration that is not allowed under current security level.
225	BF	Flashes in the bottom right corner of display when battery charge is too low.
227	Err: 227	No process data available. Consult Siemens.
228	Batch pre-act adjustment > 10%	Pre-act adjustment is ignored. Tune process to limit batch error.
240	Integrator not configured	P002-P017 must be programmed
241	No PID mA Input	PID Process Value Source (P402) or PID Setpoint (P414) has been programmed for a mA Input, however mA Input Function (P255) has not been programmed properly.

Error Code	Code Name	Message/Action
242	No PID mA Output	PID System (P400) has been turned on, but mA Output (P201) has not been programmed properly.
243	No batch setpoint relay	Batch has been set up, but no relay has been configured for a setpoint.
PF	Power Failure	Displayed at the bottom right corner of the display if power is interrupted after the integrator has been calibrated.

Certification¹⁾

For installations requiring trade certification, the BW500 and BW500/L provides a certification compliance switch. Refer to the layout diagram on page 11.

After certification of the installation has been obtained, the switch is set. The switch must be positioned to the left to enable trade certification compliance.

When the switch is set for certification, editing most parameter values, span calibrations, and main totalizer reset are denied. The maximum acceptable deviation from one zero calibration to another is limited to an accumulated $\pm 2\%$ of the zero value, and the totalizer dropout (P619) is limited to 3% or less, when the certification switch is set.

To set the certification switch, disconnect power before opening the enclosure lid.

- slide switch to the left position
- close the lid
- reconnect the power

Parameters unlocked when certification switch is set:

P000	Security Lock
P009	Time
P100 series	Relay Function (if P100 is set to '11 - Certification Rate alarm', P100 will be locked)
P560 - P569	Batch Control Functions
P648	Totalizer Reset. Unlock entry #1
P080	Damping Display
P081	Display scroll mode
P400 - P419	PID
P631	Lock index '01', unlock remaining index '02 - 05'
P634	Unlock
P635	Unlock
P647	Unlock

¹⁾ Not available with BW500/L

Certification Printing

Certification printing is allowed if the following conditions are met:

- certification switch is set
- rate is below 2 %
- a communications port has been programmed for a printer

The printout must consist of the following:

Date:	YYYY-MM-DD
Time:	HH:MM:SS
Instrument ID#:	Belt Scale serial number
Units:	Units set in P005
Start Total:	End total of previous print
End Total:	Accumulated totalizer including Start Total
Net Total:	End total minus Start Total

If a power failure occurs during totalization, power failure indicator "PF" will be printed in the middle of a new line, even if it has been cleared from the screen. "PF" will be cleared from the screen after printing.

Glossary

Auto Zero

Allows a zero calibration to be performed automatically in **RUN** mode when the load drops below the preset amount (P371) of design for 1 complete calibration period (P360).

Auxiliary Inputs

Can be programmed to allow the use of an external contact to provide the following functions, display scroll, totalizer 1 reset, Zero, Span, Multispan, Print, Batch reset, or PID functions.

Batching

The accumulation of a predetermined quantity of material.

Contacts

A junction of electrical conductors in open (not connected) or closed (connected) states.

Damping

Provides control over the speed at which the displayed rate, load, speed readings, and output functions are updated in response to changes in the internal rate signals.

Design Rate

This is the maximum material flow rate for this particular application (100% full scale).

Direct Span

If replacing software or hardware, this allows the entry of the previously recorded span value.

Differential Speed

Difference in speed at two points in a mechanical system.

Direct Zero

If replacing software or hardware, this allows the entry of the previously recorded zero value.

Factoring

Used to calculate the test load value of a new or unknown test weight using the current span as reference.

Inclinometer

Accepts incline information about conveyor or scale.

Initial Span

Usually the first span performed, it is used as reference for all other spans to determine whether they have deviated beyond the accumulated +/- 12.5%.

Initial Zero

Usually the first zero performed, it is used as reference for all other zeros to determine whether they have deviated beyond the Zero Limit (P370).

Input/Output Trim

Allows the 4 and 20 mA values to be adjusted and verified with an external source (meter).

Linearization

Compensates for non-linear output of the belt scale caused by varying load rates.

Load Cell

Strain Gauge type transducer that produces an electrical output proportional to force (load) applied.

LVDT

An electromechanical transducer that produces an electrical output proportional to the displacement of a separate movable core.

mA

A unit of measure for current flow, milliamperes.

Material Test

Material samples used to verify the accuracy of the span calibration.

Modbus

An industry standard protocol used by popular SCADA and HMI systems.

Moisture sensor

A mA input function to incorporate moisture reading from an external moisture sensor

Multispan

Since every material has its own unique physical properties, and may impact differently, a span calibration is required for each material to realize maximum accuracy.

PID

Proportional Integral Derivative control is used to control the feed rate to a setpoint, either internal to the BW500 or external.

RAM

Random Access Memory.

Random Access Memory

Memory that has both read and write capabilities.

Relay

An electromechanical device with contacts that can be closed or opened by energizing a coil.

Routine Span

Any operator initiated span calibration.

Routine Zero

Any operator initiated zero calibration.

Setpoint

A value that the integrator is trying to match.

SmartLinx

An interface to popular industrial communication systems.

SPA

Single Parameter Access, used to view or edit parameters through the available communication ports.

Span

This is a count value representing the mV signal provided by either the LVDT or Load Cell at 100% design load.

Span Register

This is the number of span calibrations that have been performed since the last master reset.

Test Weight

A calibrated weight which will represent a certain load on the scale.

Totalizer

An incremental counter that records the total of material that has been monitored.

Zero Register

Shows the number of zero calibrations that have been performed since the last master reset.

Appendix I

Memory Backup

The BW500 and BW500/L requires no maintenance or cleaning, other than a periodic replacement of the memory backup battery. Refer to *Installing/replacing the back-up battery* on page 27.

Software Updates

Software updates require Siemens Dolphin Plus software, contact your local Siemens representative.

It is recommended that the old software and parameters be saved to your PC before downloading the new software.

Once installed, a master reset (P999) must be done.

The parameters can then be reloaded, either manually or downloaded from the previously saved file. If downloading parameters via Dolphin Plus, confirm that BW500 and BW500/L is in **PROGRAM** mode. The zero and span values are included in the parameter file, However, new zero and span calibrations should be done regardless, and as soon as possible to ensure operating accuracy.

Calibration Criteria

Zero

- belt must be empty. Run the conveyor for several minutes to limber the belt and ensure that it is empty.
- test weights or chain are not used during a zero calibration
- conveyor running at normal speed
- moisture input not used during a zero calibration
- inclination will be used if feature is activated

Span

- a zero must be done prior
- belt must be empty
- test weight or chain must be applied
- conveyor running at normal speed test reference (chain or weight applied)
- moisture input not used
- inclination will be used if feature is activated

PID Systems

- zero and span criteria must be met
- set controller (P400) to manual and adjust the output for 100% belt speed (using the 4 and 8 keys).
If the PID is not set to manual, the speed output will be the last value prior to starting the zero or span calibration
- shut off the prefeed to conveyor
In process where a prefeed device is included, it must be turned off to ensure that no material is fed onto the belt.

Appendix II: Software Revision History

Software Revision	Date	Changes
2.00	April 30, 1999	<ul style="list-style-type: none"> • Original software release
2.01	July 20, 1999	<ul style="list-style-type: none"> • French language added • 38400 baud rate option removed • Span updated to reference current zero value • NTEP printout added • Totalizer rollover updated to 1,000,000 for all resolutions • Added units to verification totalizer printout • Error display updated to toggle between error and run mode
2.02	October 08, 1999	<ul style="list-style-type: none"> • Limited external contact closure to 300 msec • Added software filter to speed signal • Factoring now based on current zero value • Individual damping added for Rate, Load and Speed display • Parameters saved permanently in Flash • German added • Devicenet added • Display only the load cells selected
2.03	May 16, 2000	<ul style="list-style-type: none"> • Allow proper startup if no RAM battery installed
2.04	June 30, 2000	<ul style="list-style-type: none"> • Larger flash added
2.05	February 07, 2001	<ul style="list-style-type: none"> • SmartLinx update time increased to 250 msec. • Batch totalizer was made accessible using Modbus • New real time clock added • BW500 calibrations no longer affected by time out • Auto Zero alarm relay will now reset toggling from program to run mode
2.06	February 17, 2001	<ul style="list-style-type: none"> • Updated calibration error so that it will not display a negative 0 error, -0.00%

Software Revision	Date	Changes
3.00	April 27, 2001	<ul style="list-style-type: none"> • Added flowmeter option • Parameters are no longer changeable with remote communications when certification switch set
3.01	July 17, 2001	<ul style="list-style-type: none"> • Increased maximum idle time for SmartLinX to 9999 seconds • Fixed totalizer error when load is negative and totalizer drop out is 0.00 • Allowed access to P635 in certification mode • Setting of certification switch changes totalizer dropout to 0.00
3.02	August 07, 2001	<ul style="list-style-type: none"> • Fixed bug in totalizer P619 totalizer dropout
3.03	February 20, 2002	<ul style="list-style-type: none"> • Fixed timing issue with interval printing • Added % rate and % load to PID setpoint configuration, P414 • Updated Auto Zero to allow run display to be seen, AZ now flashes in bottom right hand corner of display • Updated span adjust calculation • Increased totalizer resolution to 100,000,000 • Improved error interruption on display • Fixed zero and span calibration using remote communications
3.04	May 09, 2002	<ul style="list-style-type: none"> • Fixed SmartLinX error checking • Fixed error with discrete inputs • Added P419 PID freeze enable/disable • Updated zero calibration when certification switch set, now references last operator initiated zero prior certification switch set • Added power failure indicator on display, "PF" • Added online calibration
3.05	November 11, 2002	<ul style="list-style-type: none"> • SmartLinX memory map increased • Improve external totalizer contact closure duration

Software Revision	Date	Changes
3.06	July 23, 2003	<ul style="list-style-type: none"> • Updated PID control between remote/local setpoint • Improve Dolphin Plus communications • Batch setpoint now adjustable in "RUN" mode • Slowed down the display when scroll key is held
3.08	March 1, 2006	<ul style="list-style-type: none"> • Remote zero and span calibrations fixed • Differential speed detection added • Moisture meter added • Inclinator feature added
3.09	August 8, 2006	<ul style="list-style-type: none"> • Remote totalizer exceeded error fixed • Totalizer dropout (P619) now limited to 3% or less when certification switch enabled
3.11	March 31, 2009	<ul style="list-style-type: none"> • Second speed sensor accuracy at frequencies below 10 Hz fixed • Parameter download using Dolphin Plus fixed (Dolphin Plus patch required) • Electronic load cell balancing of C&D fixed • Word order format with remote communication fixed • Integrator serial number added to printout • Power failure message added to printout
3.12	August 2009	<ul style="list-style-type: none"> • Fixed word order for SmartLinx

Software Revision	Date	Changes
3.13	December 2010	<ul style="list-style-type: none">• BW500/L option added• Updated eCal and test load parameters• Added option 11 to P100• Zero and Span show progress in %• Added display and mA drop-out• Totalizer dropout (P619) now limited to 25%• Improve Modbus communication• Improve Diagnostic parameter• Remote span does not require zero prior to running• Online calibration now adjusts P017 value• New language options for print strings• Added load cell values to Modbus map• 3 decimal place resolution on batch totalizer added• Updated Display options for remote parameters changes

Index

A

alarm

- condition 67, 119
- display 85
- event 85
- function 116
- high 67
- mode 118

autobaud 90

auxiliary

- input 52

B

balancing 35

baud rate 89, 108

belt

- speed compensation 41

bit values 105

C

calibration

- eCal 35, 39, 111, 114, 141, 142
- initial 35, 38, 39, 45, 46, 47, 49, 51, 52, 57, 128, 153
- online 8, 53, 54, 55, 57, 126, 160

communication

- configuring ports 88
- ports 87
- protocol 88

communications 86

- configuring ports 88
- ports 88
- protocol 88

communicatons

- ports 4

configuring communication ports 88

control

- feed forward 76
- integral 75
- output 74
- PID 77, 119
- proportional 74
- rate 71
- system 74

controller

- function 80
- logic 69, 138
- PID 77, 80

setpoint 71

D

data

- advanced access 98
- bits 90
- types 105

date and time 100

deviation

- alarm 67

discrete

- input 6, 104

Dolphin 4

- Plus 5, 86, 88, 93
- protocol 86, 93

E

ECal 141

error

- check 95
- codes 100

errors

- handling 109, 110
- messages 106

example modem setup 108

F

factoring 52, 58

format register 99, 101

function

- alarm 66
- output 66
- pre-act 85

I

initial startup 77

L

linearization 59

load cell 5, 35

LVDT 5

M

mA 6, 122

- analog 3
- I/O board 71, 80
- input 67, 80, 104, 121
- output 6, 66, 80, 104, 120
- output test 145

maximum separation 87

Modbus 98

- protocol 86, 94

- modbus
 - how modbus works 94
 - responses 109
 - RTU/ASCII protocol 94
- modem 86
- modems 107
 - available 90
 - example setup 108
 - hanging up 91
 - inactivity timeout 91
 - picking 107
 - setting up 107
 - setup 107
- modes
 - run mode 42
- mounting
 - wall mount 10
- multispan 58
- N**
- network address 89, 91, 92, 95
- P**
- P770 (IP) protocol 88
- P771 (IP) network address 89, 91, 92
- P772 (IP) baud rate 89
- P773 (IP) parity 89
- P774 (IP) data bits 90
- P775 (IP) stop bits 90
- P778 (IP) modem available 90
- P779 (G) modem inactivity timeout 91
- parameter
 - P000 security lock 111, 125
 - P001 language 111
 - P002 test reference selection 111
 - P003 number of load cells 112
 - P004 rate measurement system 112
 - P005 design rate units 112
 - P008 date 113
 - P009 time 113
 - P011 design rate 66, 69, 113
 - P014 design speed 113
 - P015 speed constant 113
 - P016 belt length 114
 - P017 test rate 114, 127
 - P019 manual span adjust 42, 115
 - P022 minimum speed frequency 115
 - P080 damping display 66, 116
 - P081 display scroll mode 139
 - P100 relay function 117, 118
 - P101 high alarm/deviation alarm 67
 - P102 low alarm 67, 118
 - P107 relay alarms 118
 - P117 relay dead band 67, 118
 - P118 relay logic 67, 119
 - P119 relay override 119
 - P200 mA output range 66, 120
 - P201 mA output function 66, 80, 120
 - P204 mA output average 120
 - P212 mA output minimum 66, 120
 - P213 mA output maximum 66, 120
 - P214 mA output trim 66, 121
 - P215 20 mA output trim 121
 - P220 mA damping 66, 121
 - P250 mA input range 67, 121
 - P255 mA input function 67, 121
 - P261 4 mA input trim 67, 122
 - P262 20 mA input trim 67, 122
 - P270 auxilliary input function 122
 - P341 days of service 125
 - P350 calibration security 125
 - P355 online calibration feature 126
 - P357 online calibration limits 126
 - P358 online calibration activation 126
 - P359 factoring 127
 - P360 calibration duration 127
 - P365 multispan 52, 127
 - P367 direct zero entry 47, 127
 - P368 direct span entry 50, 128
 - P370 zero limit deviation 128
 - P370 zero limit deviation % 128
 - P377 initial zero 128
 - P388 initial span 49, 128
 - P390 linearizer 59, 129
 - P391 linearizer load points 129
 - P392 linearizer compensation % 59, 129
 - P398 moisture content 129
 - P400 PID system 130
 - P401 PID update time 80, 130
 - P402 PID process variable source 130, 132
 - P405 proportional term 132
 - P406 integral term 132
 - P407 derivative term 132
 - P408 feed forward term 132
 - P410 manual mode 80
 - P410 manual mode output 132
 - P414 setpoint configuration 130, 133
 - P415 local setpoint value 81, 133
 - P416 external setpoint 133
 - P418 remote setpoint ratio 130, 133
 - P419 PID freeze optoin 134
 - P560 batch mode control 83, 84, 134

- P564 batch setpoint 84, 134, 135
- P566 batch pre-warn 83, 134
- P567 batch pre-warn setpoint 83, 84, 134
- P568 batch pre-act 85, 135, 137
- P569 manual batch pre-act amount 135
- P598 span adjust percentage 115, 135
- P619 totalling dropout 68, 136
- P631 totalizer resolution 136
- P635 verification totalizer 137
- P638 external totalizer resolution 68, 69, 138
- P643 external contact closure 69, 138
- P647 totalizer display 70, 139
- P648 totalizer reset, internal 70
- P648 totalizer reset, internal 139
- P690 speed constant entry 139, 140
- P691 drive pulley diameter 140
- P693 belt scale model 141
- P694 ecal load cell capacity 141
- P695 ecal load cell sensitivity 141
- P697 ecal idler spacing 142
- P698 ecal conveyor inclination 142
- P699 ecal mV span 142
- P735 back light 142, 143
- P750-P769 SmartLinx module-specific parameters 143
- P770-P789 local port parameters 88, 143
- P771 (IP) network address 89
- P773 parity 89
- P775 stop bits 90
- P778 modem attached 90
- P781 data message 92
- P792 SmartLinx error count 143
- P799 communications control 92, 145
- P900 software revision 145
- P901 memory test 145
- P911 mA output test 104, 145
- P914 mA input value 145
- P918 speed input frequency 145
- P940 load cell LVDT interface mV signal test 146
- P943 load cell A/D reference 146
- P948 error log 146
- P999 master reset 70, 147
- parameters
 - read and write 98
 - reading 98
 - SmartLinx hardware testing 143
 - values 105
 - writing 99
- parity 89
- PID 67, 77, 105
 - control 105
 - function 6, 66
 - manual mode 80
 - setpoint 67, 121
 - setup and tuning 74, 77
- product ID 98
- protocol 88
- R**
- RAM 6
- rate
 - control 71, 77
- register map 95, 98
- relay 71, 83, 84, 85, 118
 - alarm 67
 - batch 134
 - contacts 7
 - functions 117
 - setpoint 135
- remote
 - setpoint 133
- reset
 - master 70, 146
- RS-232 25
- S**
- s 143
- SCADA 86
- setpoint 134
 - batch 85
 - local 133
 - PID 121
 - rate 77
 - relay 135
 - remote 133
- SmartLinx 87, 88
- span 50, 128
 - adjust 42, 45
 - calibration 42, 45, 50, 51, 52, 59
 - correction 50
 - direct 50
 - initial 49, 50, 52
 - manual 42, 135
 - multispan 50, 52
 - mV 142
 - recalibration 46, 47, 49
 - remote 52
 - routine 48
 - verification 137
- stop bits 90

T

term

- derivative 75, 132
- forward 132
- integral 132
- proportional 132

test

- load 42, 58, 127, 142
- material 42, 61, 130
- value 145

text messages 106

totalizer 70, 139

- functions 68
- internal 137
- master 68

troubleshooting 148

U

UDINT 105

UINT32 order 98

unsigned double precision integer 105

W

web site 94

wiring

- 9-pin to RJ-11 25, 27
- guidelines 87

Z

zero 6

- auto 47
- calibration 38, 45, 58
- direct 47
- initial 45, 46, 47
- recalibration 46, 47
- verification 137

For more information

www.siemens.com/level

www.siemens.com/weighing

Siemens AG
Industry Sector
1954 Technology Drive
P.O. Box 4225
Peterborough, ON
Canada K9J 7B1

email: techpubs.smpi@siemens.com

www.siemens.com/processautomation

Subject to change without prior notice
7ML19985DK05 Rev. 5.1

© Siemens AG 2012



7 M L 1 9 9 8 5 D K 0 5
Printed in Canada