

Operating and Service Manual

Mini 11-101F
Field Mount Integrator

Thermo Ramsey

REC 3968 Rev. G
Part No. 051033

Operating and Service Manual

Mini 11-101F Field Mount Integrator

This document is confidential and is the property of Thermo Ramsey ("Ramsey"). It may not be copied or reproduced in any way without the express written consent of Ramsey. This document also is an unpublished work of Ramsey. Ramsey intends to and is maintaining the work as confidential information. Ramsey also may seek to protect this work as an unpublished copyright. In the event of either inadvertent or deliberate publication, Ramsey intends to enforce its rights to this work under the copyright laws as a published work. Those having access to this work may not copy, use, or disclose the information in this work unless expressly authorized by Ramsey.

All registered and unregistered trademarks are the property of their respective owners.

Thermo Ramsey
501 90th Avenue N.W.
Minneapolis, MN 55433 U.S.A.
Tel (763) 783-2500
Fax (763) 783-2525
<http://www.ThermoRamsey.com>
© 2000 Thermo Ramsey
Printed in the U.S.A.

Thermo Ramsey

REVISION HISTORY

Revision A	August 1996
Revision B	March 1997
Revision C	September 1997
Revision D	October 1997
Revision E	March 1998
Revision F	February 1999
Revision G	December 2000

Contents

About this Manual

Who Should Use this Manual?	xiii
Organization of the Manual	xiii
Documentation Conventions	xiv
Safety Messages.....	xiv
General Precautions	xv
Occupational Safety and Health Act (OSHA)	xvi
Thermo Ramsey Warranty	xvi
Disclaimer	xvii

Chapter 1: Introduction to the Mini 11-101F Field Mount Inte- grator

1.1 Overview.....	1-1
1.2 Belt Scale System Description.....	1-1
1.3 Mini 11-101F Integrator Description	1-2
1.3.1 Standard Configuration	1-3
1.3.2 Measuring Functions	1-3
1.3.2.1 Instantaneous Flow Rate Calculation	1-3
1.3.2.2 Flow Totalization	1-4
1.3.2.3 Automatic Zero and Span Calibrations.....	1-4
1.3.2.4 Auto Zero Tracking.....	1-4
1.3.2.5 Setting the Auto Zero Track Range (AZT Range)	1-5
1.3.2.6 Dead Band.....	1-5
1.3.2.7 Current Output Signals.....	1-5
1.3.3 Monitoring Functions.....	1-6
1.3.3.1 Status Indications	1-6
1.3.3.2 Process Alarms	1-6
1.3.3.3 Programming Errors	1-7
1.3.3.4 Equipment Failures.....	1-7
1.3.4 Print Functions	1-8
1.3.5 Operator Interface.....	1-8
1.3.5.1 Front Panel	1-8
1.3.5.2 Display	1-9
1.3.5.3 LED Indicators	1-9
1.3.5.4 Keypad	1-9
1.4 Menu Structure	1-10
1.5 Data Entry.....	1-10
1.5.1 Navigating the Menus	1-10

**Chapter 2:
Installing and Setting Up
the Mini 11-101F Integra-
tor**

1.5.2	Entering Numbers.	1-11
1.5.3	Selecting Default Values or Changing a Value Selection.	1-11
1.6	Technical Specifications.	1-11
2.1	Overview.	2-1
2.2	Installation Considerations	2-1
2.2.1	Equipment Location	2-2
2.2.2	Environmental Factors	2-2
2.2.3	Input Power Requirements	2-2
2.2.4	Safety Precautions	2-2
2.3	Equipment Handling.	2-3
2.4	Storing the Mini 11-101F.	2-4
2.5	Inspection and Unpacking	2-4
2.6	Installing the Mini 11-101F	2-4
2.6.1	Site Selection	2-4
2.6.2	Mounting the Control Unit.	2-5
2.6.3	Wiring the Mini 11-101F Integrator.	2-6
2.6.3.1	Critical Wiring Conditions	2-6
2.6.3.2	Field Wiring Procedure.	2-7
2.6.3.3	Connecting Power to the Unit.	2-7
2.7	Configuring the Mini 11-101F Integrator.	2-9
2.8	Input Power Selection Switches	2-9
2.8.1	Load Cell Sense	2-11
2.8.2	General Purpose Digital Input Configuration	2-11
2.8.3	General Purpose Digital Output Configuration	2-12
2.8.4	Analog Output Configuration.	2-12
2.8.5	Optional Print Configuration	2-12
2.9	Powering Up the Mini 11-101F Integrator.	2-14
2.10	Initial Set Up and Programming	2-14
2.10.1	Selecting the Language	2-14
2.10.2	Recording Installation Parameters	2-15
2.10.3	Specifying Scale Data During Set-Up	2-17
2.10.3.1	Scale Units	2-18
2.10.3.2	Decimal Place	2-19
2.10.3.3	Scale Capacity.	2-20
2.10.3.4	Load Cell Capacity	2-20
2.10.3.5	Number of Load Cells (Cells Number)	2-21
2.10.4	Specifying Calibration Data During Set-Up	2-21
2.10.4.1	Selecting the Calibration Method	2-21
2.10.4.2	Defining Electronic Res (R-Cal) Parameters	2-22
	R-Cal Mode	2-22

Load Cell Sensitivity 2-23
 Cell Resistance 2-23
 Calibration Resistance 2-24
 Lever Ratio 2-24
 Idler Spacing 2-25
 Idlers Number 2-25
 Conveyor Angle 2-25
 2.10.5 Acquiring the Test Duration 2-26
 2.10.6 Introduction to Calibration 2-29

**Chapter 3:
 Operating the Mini
 11-101F Integrator**

3.1 Overview 3-1
 3.2 Run Menu Procedures 3-1
 3.3 Handling Pending Alarms 3-2
 3.4 Calibrating the Mini 11-101F Integrator 3-4
 3.4.1 Zero Calibration 3-4
 3.4.1.1 Auto Zero 3-4
 3.4.1.2 Manual Zero 3-5
 3.4.2 Span Calibration 3-5
 3.4.2.1 Auto Span Calibration Using R-Cal Input ... 3-6
 3.4.2.2 Auto Span Calibration Using Test Weights or
 Chains 3-7
 3.4.2.3 Auto Span Calibration Using Material 3-8
 Material Post Span Procedures 3-9
 3.4.2.4 Factoring R-Cal After Span Calibration With
 Weights or Material 3-10
 3.4.2.5 Factoring Test Weights/Chains Calcon After Span
 Calibration With Material 3-11
 3.4.2.6 Manual Span Calibration 3-12
 3.4.3 Routine Calibration 3-12
 3.4.3.1 Routine Zero Calibration 3-13
 3.4.3.2 Routine Span Calibration Using Electronic Cali-
 bration 3-13
 3.4.3.3 Routine Span Calibration Using Weight or Calibra-
 tion Chains 3-14
 3.4.4 Keeping a Calibration Record 3-15
 3.5 Setting Up Protection Level 3-16
 3.5.1 Defining a Password 3-16
 3.5.2 Activating a Password 3-16

**Chapter 4:
Maintaining and Troubleshooting the Mini
11-101F Integrator**

4.1 Overview. 4-1

4.2 Safety Precautions 4-2

4.3 Routine Maintenance 4-3

 4.3.1 Cleaning Instructions 4-3

 4.3.2 Preventive Maintenance 4-3

 4.3.3 Calibration Checks 4-4

 4.3.3.1 Zero Calibration Shifts 4-4

 4.3.3.2 Span Calibration Shifts 4-4

4.4 Troubleshooting and Maintenance Procedures. 4-5

 4.4.1 Visual Inspection 4-5

4.5 Alarm Messages 4-6

 4.5.1 Process Alarms 4-6

 4.5.2 Hardware Alarms/ Self Test Procedure 4-6

 4.5.2.1 Displaying Raw A/D Data (A/D Gross) 4-7

 4.5.2.2 Displaying Raw A/D Data (A/D Net) 4-7

 4.5.2.3 Displaying Pulse per Minute (Pls/Min) 4-7

 4.5.2.4 Displaying Belt Speed (SP) 4-7

 4.5.2.5 Displaying Belt Loading (PS) 4-7

 4.5.2.6 Displaying Load Cell Output (LC SUP) 4-7

 4.5.2.7 Displaying Correction Zero (C_Zero) 4-8

 4.5.2.8 Displaying Correction Span (C_Span) 4-8

 4.5.2.9 Displaying the Software Version
(Softwar Ver) 4-8

 4.5.2.10 Testing Memory 4-8

 4.5.2.11 Testing Input 4-9

 4.5.2.12 Testing Output 4-9

 4.5.2.13 Lamp Test 4-9

 4.5.2.14 Entering a Forced Value 4-9

 4.5.3 Load Cell Excitation and Signal Voltage. 4-10

 4.5.4 Cold Start Procedure 4-10

 4.5.5 Removing a Forgotten Password 4-14

 4.5.6 Resetting the Master Total 4-14

 4.5.7 Replacing the Lithium Battery 4-15

4.6 Jumper and Switch Configuration on Circuit Boards. 4-15

**Chapter 5:
Service, Repair, and Re-
placement Parts**

5.1 Service and Repair Information 5-1

5.2 Parts Ordering Information. 5-1

5.3 Return Material Authorization 5-3

5.4 Parts List 5-4

 5.4.1 Disposal of Hazardous Waste 5-4

**Appendix A:
Mini 11-101F Menus**

A.1 Run Menu A-1

A.2 Set-up Menu..... A-3

 A.2.1 Protection Menu A-3

 A.2.2 Scale Data Menu A-4

 A.2.2.1 Setting the Scale Units..... A-4

 A.2.2.2 Decimal Place A-5

 A.2.2.3 Scale Capacity A-5

 A.2.2.4 Setting the Load Cell Capacity
(LCELL CAP) A-5

 A.2.2.5 Setting the Number of Load Cells
(Cells Number)..... A-5

 A.2.2.6 Setting the Filter Damping..... A-6

 A.2.2.7 Setting the Low Rate Set A-6

 A.2.2.8 Setting the High Rate Set..... A-6

 A.2.2.9 Setting the Rate Alarm Delay A-6

 A.2.2.10 Setting the Auto Zero Track Range
(AZT Range) A-7

 A.2.2.11 Setting the Auto Zero Tracking Limit
(Limit AZT) A-7

 A.2.2.12 Setting the Dead Band A-7

 A.2.3 Calibration Menu..... A-8

 A.2.3.1 Calibration Mode A-8

 A.2.3.2 R-CAL Mode A-8

 A.2.3.3 Cell mV/V - Load Cell Sensitivity..... A-8

 A.2.3.4 Cell Resistance..... A-8

 A.2.3.5 Calibration Resistance A-9

 A.2.3.6 Lever Ratio..... A-9

 A.2.3.7 Idler Spacing A-9

 A.2.3.8 Idlers Number A-9

 A.2.3.9 Conveyor Angle A-9

 A.2.3.10 Calibration Constant R-Cal A-10

 A.2.4 Input/Output (I/O Data) Menu..... A-10

 A.2.4.1 Defining Range mA - Output Range A-10

 A.2.4.2 Defining Current Damping A-10

 A.2.4.3 Defining Divide Out - Divisor for the Remote
Counter..... A-10

 A.2.4.4 Defining Pulse Width..... A-11

 A.2.4.5 Defining Speed Input (Input 1) A-11

 A.2.4.6 Defining Language..... A-11

 A.2.4.7 Defining Input 2..... A-11

 A.2.4.8 Defining Input 3..... A-11

 A.2.4.9 Defining Input 4..... A-12

 A.2.4.10 Defining Output 1 A-12

- A.2.4.11 Defining Output 2 A-12
- A.2.4.12 Defining Output 3 A-12
- A.2.4.13 Defining Output 4 A-14
- A.2.4.14 Defining Output 5 A-14
- A.2.4.15 Defining Alternate Rate Total - Alt.
Rate-Tot A-14
- A.2.4.16 Defining Data Format A-14
- A.2.5 Alarm Definition Menu A-15
 - A.2.5.1 Low Rate A-15
 - A.2.5.2 High Rate A-15
 - A.2.5.3 Remote Counter Overflow
(REM CNT OVRFL) A-16
 - A.2.5.4 Belt Pulse Counter Overflow
(BELT PLS CNT OVF) A-16
 - A.2.5.5 Cold Start A-16
 - A.2.5.6 Load Cell Fail A-16
 - A.2.5.7 Max Zero Correction A-16
 - A.2.5.8 Math Error A-17
- A.2.6 Printer Scroll (Optional) Menu A-17
 - A.2.6.1 Baud Rate A-17
 - A.2.6.2 Stop Bits A-17
 - A.2.6.3 Parity A-17
 - A.2.6.4 Word Length A-18
 - A.2.6.5 Handshake A-18
 - A.2.6.6 End of Line A-18
 - A.2.6.7 Delay End of Line A-18
 - A.2.6.8 Print Interval A-18
 - A.2.6.9 Report Format A-19
 - A.2.6.10 String #1 A-19
 - A.2.6.11 Contents String #1 A-19
 - A.2.6.12 String #1 Position A-19
 - A.2.6.13 String #2 A-19
 - A.2.6.14 Contents String #2 A-20
 - A.2.6.15 String #2 Position A-20
 - A.2.6.16 String #3 A-20
 - A.2.6.17 Contents String #3 A-20
 - A.2.6.18 String #3 Position A-20
 - A.2.6.19 Rate Position A-20
 - A.2.6.20 Master Total Position (Mtotal Pos) A-20
 - A.2.6.21 Reset Total Position (Rtotal POS) A-21
 - A.2.6.22 Date Position A-21
 - A.2.6.23 Time Position A-21
- A.2.7 Test Menu A-21

A.2.7.1 Setting Up Passwords A-21

A.2.7.2 Displaying Raw A/D Data (A/D Gross) A-22

A.2.7.3 Displaying Raw A/D Data (A/D Net) A-22

A.2.7.4 Displaying Pulse per Minute (Pls/Min) A-22

A.2.7.5 Displaying Belt Speed (SP) A-22

A.2.7.6 Displaying Belt Loading (PS) A-22

A.2.7.7 Displaying Load Cell Output (LC SUP) A-22

A.2.7.8 Displaying Correction Zero (C_Zero) A-23

A.2.7.9 Displaying Correction Span (C_Span) A-23

A.2.7.10 Displaying the Software Version
(Softwar Ver) A-23

A.2.7.11 Testing Memory A-23

A.2.7.12 Testing Input A-23

A.2.7.13 Testing Output A-24

A.2.7.14 Lamp Test A-24

A.2.7.15 Entering a Forced Value A-24

A.2.7.16 Setting the Time (Optional COMM Board) A-24

A.2.7.17 Setting the Date (Optional COMM Board) A-25

A.3 Permanent Scroll Record for Set-Up Scrolls A-25

**Appendix B:
Mini 11-101F Integrator
Menu Trees**

B.1 Overview B-1

**Appendix C:
Mini 11-101F Integrator
Engineering Drawings**

C.1 Overview C-1

List of Figures

Figure 1-1. Belt Scale System Diagram	1-2
Figure 1-2. Mini 11-101F Integrator Front Panel	1-8
Figure 1-3. Logic Diagram - Speed Sensor Input	1-14
Figure 1-4. Logic Diagram - General Purpose Digital Inputs 2, 3, and 4	1-15
Figure 1-5. Relay Outputs	1-16
Figure 1-6. Logic Diagram: High-Level Analog Output	1-17
Figure 1-7. Signal Connections: Printer Option	1-18
Figure 2-1. Typical Integrator Installation	2-4
Figure 2-2. Outline and Mounting Dimensions	2-5
Figure 2-3. Input Power Connections	2-8
Figure 2-4. Mother Board	2-10
Figure 2-5. Relay Board	2-11
Figure 2-6. Communication Board	2-13
Figure 2-7. Measuring the Angle of Incline	2-17
Figure C-1. Field Wiring Diagram	C-2

About this Manual

This manual provides the information you need to install, operate, and maintain the *Mini 11-101F Field Mount Integrator*. This revision documents version 44.00.10.01 of integrator software.

Read this manual before working with the system. For personal and system safety, and for the best product performance, make sure you thoroughly understand the manual before installing, operating, or maintaining this machine.

Who Should Use this Manual?

The *Mini 11-101F Field Mount Integrator Operating and Service Manual* is a learning resource and reference for anyone concerned with installing, operating, or maintaining the integrator in a belt scale application.

Organization of the Manual

This manual is organized into five chapters and three Appendices.

Chapter 1: Introduction to the Mini 11-101F Integrator gives you an overview of the device's capabilities, describes its functions, and lists its technical specifications.

Chapter 2: Installing the Mini 11-101F Integrator provides information about installing the Mini 11-101F Integrator including procedures for mounting, wiring, and configuring the system.

Chapter 3: Operating the Mini 11-101F Integrator provides information about setting up and operating the integrator. It includes a thorough description of the operator interface.

Chapter 4: Maintaining the Mini 11-101F provides information about maintenance and troubleshooting. It includes procedures for determining and correcting operational problems.

Chapter 5: Service, Repair, and Replacement Parts tells you how to contact Ramsey service departments for assistance and how to order parts for your Mini 11-101F Integrator.

Appendix A: Mini 11-101F Menus contains an overall description of the integrator menu items.

Appendix B: Mini 11-101F Integrator Menu Trees contains a condensed version of the menus and the sub-menus associated with them.

Appendix C: Mini 11-101F Engineering Drawings contains engineering drawings applicable to the Mini 11-101F Integrator.

Documentation Conventions

The following conventions are used in this manual to help easily identify certain types of information:

- *Italic type* is used for references to other manuals. *Italic* is also used to introduce new terms and for emphasis.
- Names of keys are shown in **BOLD CAPITALS**.
- Names of menus and scrolls are shown in **FULL CAPITALS**.

Safety Messages

Instructions in this manual may require special precautions to ensure the safety of the personnel performing the operations. Potential safety issues are indicated by this symbol: . Please read the safety information before performing any operation preceded by this symbol.

There are two levels of safety messages: warnings and cautions. The distinction between the two is as follows:

 WARNING
Failure to observe could result in death or serious injury.

 CAUTION
Failure to observe may cause minor injury or damage the equipment.

General Precautions

Do not install, operate, or perform any maintenance procedures until you have read the safety precautions presented below.

WARNING

Failure to follow safe installation and servicing procedures could result in death or serious injury.

- Make sure only qualified personnel perform installation and maintenance procedures in accordance with the instructions in this manual.
- Allow only qualified electricians to open and work in the electronics cabinets, power supply cabinets, control cabinets, or switch boxes.
- Covers over the electronics and rotating parts must always remain in place during normal operation. Remove only for maintenance, with the machine's power OFF. Replace all covers before resuming operation.
- During maintenance, a safety tag (not supplied by the factory) is to be displayed in the ON/OFF switch areas instructing others not to operate the unit (ANSI:B157.1).

WARNING

High voltage that may be present on leads could cause electrical shock.

- All switches must be OFF when checking input AC electrical connections, removing or inserting printed circuit boards, or attaching voltmeters to the system.
- Use extreme caution when testing in, on, or around the electronics cabinet, PC boards, or modules. There are voltages in excess of 115 V or 230 V in these areas.

CAUTION

Keep hands and clothing away from all moving or rotating parts.

CAUTION

Do not place or store objects of any kind on the machine.

 **CAUTION**

This machine should not be operated at more than the production rate stated on your Equipment Specification sheet or used in applications other than those stated in the original order.

- Weighing accuracy may be adversely affected by changes in production rate or application.
- To adapt production rates or applications, contact your service representative.

Occupational Safety and Health Act (OSHA)

The Occupational Safety and Health Act clearly places the burden of compliance on the user of the equipment and the act is generalized to the extent that determination of compliance is a judgement decision on the part of the local inspection. Hence Thermo Ramsey will not be responsible for meeting the full requirements of OSHA in respect to the equipment supplied or for any penalty assessed for failure to meet the requirements, in respect to the equipment supplied, of the Occupational Safety and Health Act, as interpreted by an authorized inspector. Thermo Ramsey will use their best efforts to remedy such violation at a reasonable cost to the buyer.

Thermo Ramsey Warranty

The seller agrees, represents, and warrants that the equipment delivered hereunder shall be free from defects in material and workmanship. Such warranty shall not apply to accessories, parts, or material purchased by the seller unless they are manufactured pursuant to seller's design, but shall apply to the workmanship incorporated in the installation of such items in the complete equipment. To the extent purchased parts or accessories are covered by the manufacturer's warranty, seller shall extend such warranty to buyer.

Seller's obligation under said warranty is conditioned upon the return of the defective equipment, transportation charges prepaid, to the seller's factory in Minneapolis, Minnesota, and the submission of reasonable proof to seller prior to return of the equipment that the defect is due to a matter embraced within seller's warranty hereunder. Any such defect in material and workmanship shall be presented to seller as soon as such alleged errors or defects are discovered by purchaser and seller is given opportunity to investigate and correct alleged errors or defects and in all cases, buyer must have notified seller thereof within one (1) year after delivery, or one (1) year after installation if the installation was accomplished by the seller.

Said warranty shall not apply if the equipment shall not have been operated and maintained in accordance with seller's written instructions applicable to such equipment, or if such equipment shall have been repaired or altered or modified without seller's approval; provided, however, that the foregoing limitation of warranty insofar as it relates to repairs, alterations, or modifications, shall not be applicable to routine preventive and corrective maintenance which normally occur in the operation of the equipment.

“EXCEPT FOR THOSE WARRANTIES SPECIFICALLY CONTAINED HEREIN, SELLER DISCLAIMS ANY AND ALL WARRANTIES WITH RESPECT TO THE EQUIPMENT DELIVERED HEREUNDER, INCLUDING THE IMPLIED WARRANTIES OF MERCHANTABILITY AND FITNESS FOR USE. THE SOLE LIABILITY OF SELLER ARISING OUT OF THE WARRANTY CONTAINED HEREIN SHALL BE EXCLUSIVELY LIMITED TO BREACH OF THOSE WARRANTIES. THE SOLE AND EXCLUSIVE REMEDY FOR BREACH OF THE WARRANTIES SET OUT ABOVE SHALL BE LIMITED TO THE REPAIR OR REPLACEMENT OF ANY DEFECTIVE ACCESSORY, PART OR MATERIAL WITH A SIMILAR ITEM FREE FROM DEFECT, AND THE CORRECTION OF ANY DEFECT IN WORKMANSHIP. IN NO EVENT SHALL SELLER BE LIABLE FOR ANY INCIDENTAL OR CONSEQUENTIAL DAMAGES.”

Purchaser agrees to underwrite the cost of any labor required for replacement; including time, travel, and living expenses of Ramsey Field Service Engineer at closest factory base.

THERMO RAMSEY
501 90th Avenue N.W.
Minneapolis, MN 55433
Phone: (763) 783-2500
Fax: (763) 780-1537

Disclaimer

Though the information provided herein is believed to be accurate, be advised that the information contained herein is *not* a guarantee for satisfactory results. Specifically, this information is neither a warranty nor guarantee, expressed or implied, regarding performance, merchantability, fitness, or any other matter with respect to the products, and recommendation for use of the product/process information in conflict with any patent. Please note that Thermo Ramsey reserves the right to change and/or improve the product design and specifications without notice.

Chapter 1

Introduction to the Mini 11-101F Field Mount Integrator

This chapter introduces the *Mini 11-101F Field Mount Integrator*. It gives you an overview of the device's capabilities, describes its basic functionality, and lists its technical specifications.

1.1 Overview

The Mini 11-101F Field Mount Integrator is a simple, microprocessor based integrator that provides basic rate and total information in a belt conveyor scale system.

In most installations, no modification of existing equipment is necessary to accommodate the Mini 11-101F Integrator.

1.2 Belt Scale System Description

The Mini 11-101F Integrator can be used with various Ramsey scale systems. Belt conveyor scales provide a means of weighing bulk materials while in motion. The weight on the conveyor belt is measured by sensing the force on one or more conveyor idlers. The motion of the material is measured by sensing travel of the belt with a device which produces an "output" representing a fixed distance of belt travel. The measured force represents weight per unit length (kg/m or lbs/ft), it can be multiplied by the belt travel to acquire total weight. (Example: $\text{lbs/ft} \times \text{ft} = \text{lbs}$; $\text{Kg/m} \times \text{m} = \text{Kg}$).

Figure 1-1 shows a simplified functional diagram of a belt scale system with an integrator.

Figure 1-1. Belt Scale System Diagram

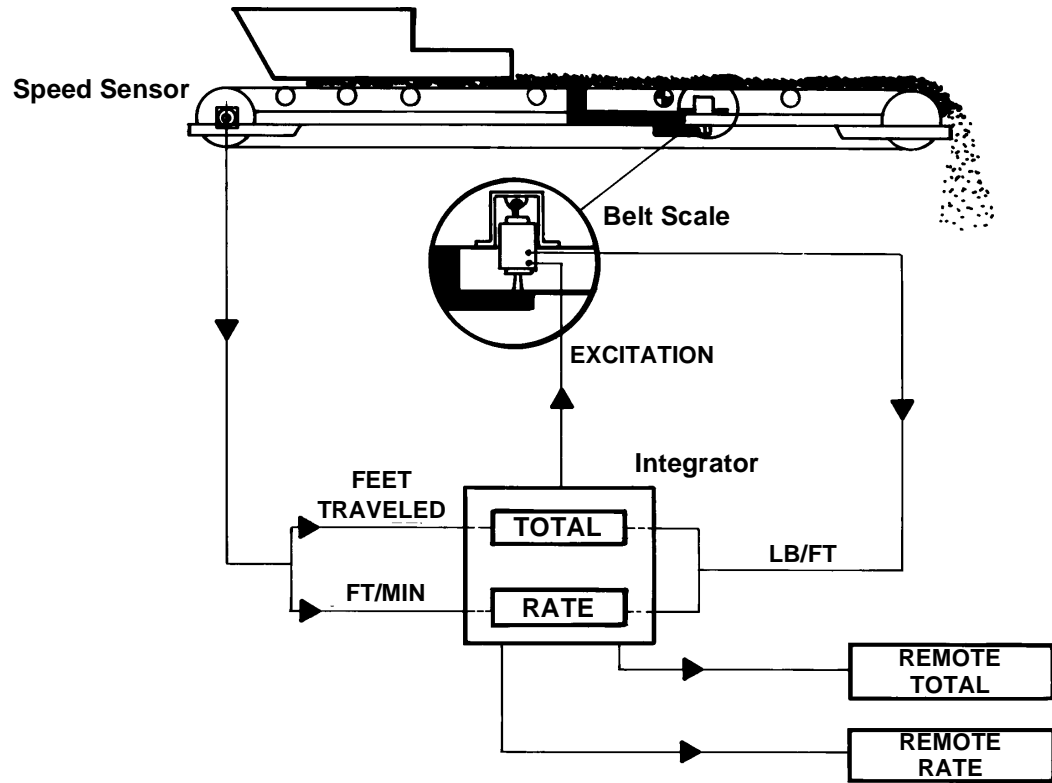

$$TOTAL = LB/FT \times FEET TRAVELED$$

$$RATE = LB/FT \times FT/MIN$$

A00805

1.3 Mini 11-101F Integrator Description

The Mini 11-101F Integrator is a microprocessor-based instrument that derives the rate and quantity of material flowing over a belt scale from signals representing the weight per belt length of moving material (lb/ft) and belt travel (ft/min).

By processing these two input signals along with belt speed, the integrator produces visible and electrical outputs representing the rate of material movement and the total amount of material that has passed over the belt conveyor scale.

The Mini 11-101F Integrator uses a millivolt analog input signal from the load cell(s) and comes standard with a 4–20 mA analog output for remote flow rate indication. It has provisions for three programmable digital inputs and four programmable digital outputs, one for remote totalization. There are three options available for remote indicating:

- Remote totalization
- Remote flow rate
- Printing

The integrator functions are resident in the software of the microprocessor. The optional printer function is available for serial output connection to a printer when the required communication board is installed.

The Mini 11-101F Integrator supports these additional features:

- Menu driven operator entries from a front panel
- Five LED status indicators
- Non-volatile RAM for storing programming information
- Automatic zero and span calibration
- Auto zero tracking
- Programmable digital inputs and outputs
- Alarms and failure detection
- Remote load cell sense line connections for distances over 200 ft

1.3.1 Standard Configuration

The standard configuration of the Mini 11-101F Integrator includes:

- Analog output for remote material flow rate indication
- Four digital dry contact outputs, one for remote totalization
- Three dry contact digital status inputs

1.3.2 Measuring Functions

The Mini 11-101F Integrator is directly connected to up to four 350 ohm *load cells* from which it receives output signals representing the weight of material on the belt. It receives pulse stream signals from the *speed sensor* that it uses to calculate belt speed and feed rate.

1.3.2.1 Instantaneous Flow Rate Calculation

The signal delivered by the load cell(s), which represents the *weight per unit length* on the belt (lb/ft), is multiplied by the signal delivered by the speed sensor, which represents the *belt speed* (ft/min).

The result of this operation is the instantaneous *flow rate* (lb/ft × ft/min = lb/min), which is in turn multiplied by a constant to obtain the value in the required engineering units (kg/hour, ton/hour). An adjustable *damping filter* is provided for displayed rate.

1.3.2.2 Flow Totalization

Rate is integrated in time to calculate the *total* amount of material conveyed by the belt, which is displayed in two individual registers: master total and reset total. The total is accumulated by multiplying [weight per unit length] by [incremental length] and totalizing the result in engineering units.

Two totalizing memories are provided:

- The first memory (Master Total) cannot be reset, which guarantees that the data is not lost because of an unintentional reset.
- The second memory (Reset Total) can be reset by the operator and is normally used for shift or daily totalization.

1.3.2.3 Automatic Zero and Span Calibrations

The Mini 11-101 Integrator can perform *automatic zero* and *automatic span* calibrations. Zero and span calibrations are based on belt length defined by the number of belt revolutions.

To calculate the exact number of revolutions, the instrument counts the pulses delivered by the speed sensor (one pulse represents a specific belt length). When the required number of pulses is reached, the instrument ends the calibration test and compares the actual totalized value to the theoretical value (0 for zero calibration), and calculates the correct settings for zero or span.

1.3.2.4 Auto Zero Tracking

When the belt is running and the rate is below a certain percentage of scale capacity, the Mini 11-101F can perform *auto zero tracking* (AZT) to minimize zero error caused by material and dust buildup.

Under a preset minimum flow rate, the Mini 11-101F makes subsequent automatic zero calibrations in this sequence:

1. Waits for ½ the time of the established test duration (a solid 'Z' will be displayed)
2. Executes a zero test (the 'Z' will flash)
3. Performs an automatic zero for one test duration
4. Continuously repeats the above zero calibration as long as the feed rate remains below the AZT preset value

The AZT function is limited to a maximum value of zero limit that is set in percent in the **SCALE DATA** scroll. If the new zero calculated by AZT exceeds that value, an alarm is generated and the new zero is not installed. The reference value for zero is reset every time an auto zero or manual zero is performed.

1.3.2.5 Setting the Auto Zero Track Range (AZT Range)

AUTO ZERO TRACKING, when enabled, allows continuous unassisted auto zeroing if the flow rate is less than an amount in percent of scale capacity (AZT Range in scale data). The flow rate must remain below AZT range for at least 2 test durations for a successful Auto Zero Track cycle to be completed.

Auto Zero Tracking is enabled by entering a value other than zero. When enabled, a 'Z' will appear in the left hand side of the flow rate display. When the 'Z' is steady it indicates that the actual AZT cycle has started. The 'Z' continues flashing until the cycle is complete and zero is automatically changed if necessary. This procedure repeats itself as long as the belt is running and the flow rate remains below AZT range.

1.3.2.6 Dead Band

The DEAD BAND is a percentage of the scale capacity (rate) in which the rate is ignored and a zero rate is forced. Totalization is frozen when the rate is below the dead band setting.

1.3.2.7 Current Output Signals

The standard Mini 11-101F is equipped with one electrical current output signal (0–20/4–20/20–0/20–4 mA) for remote flow rate. Analog output can be smoothed via a *damping filter* that can be programmed for time or length delay.

Displayed variables and analog output can be smoothed via *damping filters*.

1.3.3 Monitoring Functions

The Mini 11-101F Integrator is equipped with internal diagnostics and an indicator and control system that notifies you of:

- Status
- Process alarms
- Programming errors
- Equipment failures

If any of the controlled conditions occurs, it is indicated by an LED lighting on the Mini 11-101F front panel and by a digital output.

Alarms are shown on the front panel display and can be acknowledged and reset through the operator interface or digital input. Each individual alarm can be programmed to operate as alarm, shut down, or to be ignored.

1.3.3.1 Status Indications

The following status indications are shown on the Mini 11-101F front panel:

- Conveyor belt is running
The **RUN** LED is lit.
- There is an alarm that has been triggered
The **ALARM** LED is lit and the screen is flashing the alarm name.
- The integrator is in the process of doing a span calibration
The **SPAN CAL** LED is lit.
- The integrator is performing zero calibration
The **ZERO CAL** LED is lit
- Power applied, scale calibrated, no alarms, and the ready LED is lit

1.3.3.2 Process Alarms

The following process conditions are monitored and produce alarms or shut down according to how they are defined in the Mini 11-101F configuration. A delay time before the abnormal condition is monitored may be set for each individual alarm.

- Low Rate
- High Rate
- Remote Counter Overflow
- Belt Pulse Counter Overflow

Each alarm condition can be defined as:

- Alarm - Generate an alarm message. The machine continues to run.
When an alarm occurs, the **ALARM** LED on the front panel and the word “ALARM” on the menu screen are flashing.

- Fail - Generate an alarm message and turn off the **READY** LED and output. The machine stops.

When a fail alarm occurs, the **ALARM** LED on the front panel and the word specific alarm on the display are flashing. The **READY** LED goes off.

- None - Alarm is deactivated; no action.

1.3.3.3 Programming Errors

Programming errors occur only during set up or calibration of the Mini 11-101F. They result from entering data that is outside of the operating range for the instrument. If you enter data that is lower or higher than the limits for a given parameter, the system displays a warning message. You will have to enter valid parameters before continuing with set up and calibration.

1.3.3.4 Equipment Failures

The following operating conditions can be monitored and produce alarms or shut down according to how they are defined in the integrator configuration. A delay time before the abnormal condition is monitored may be set for each individual alarm.

- Cold Start
- Load Cell Failure
- Maximum Zero Correction
- Math Error

1.3.4 Print Functions

The following print functions are available when the optional communication board is installed and configured in the Mini 11-101F.

- Print on command - From the front panel, the integrator has the ability to print current conditions.
- Print at preselected time intervals - Specifies the interval of time between automatic printouts of the totals.
- Print machine setup - Allows you to define the parameters of your printer and the resulting printout definitions.

1.3.5 Operator Interface

The operator interface to the Mini 11-101F Integrator is used for initial setup and machine operation. The *front panel* provides an LED *display* for viewing run time information or system menus and a *keypad* for entering data and performing operations. The operator interface is based on a menu structure that guides you through setup and maintenance activities.

1.3.5.1 Front Panel

The front panel contains the indicators and keys you use to set up the Mini 11-101F. It is also used to perform calibrations and all required operations after the system has been configured.

Figure 1-2. Mini 11-101F Integrator Front Panel

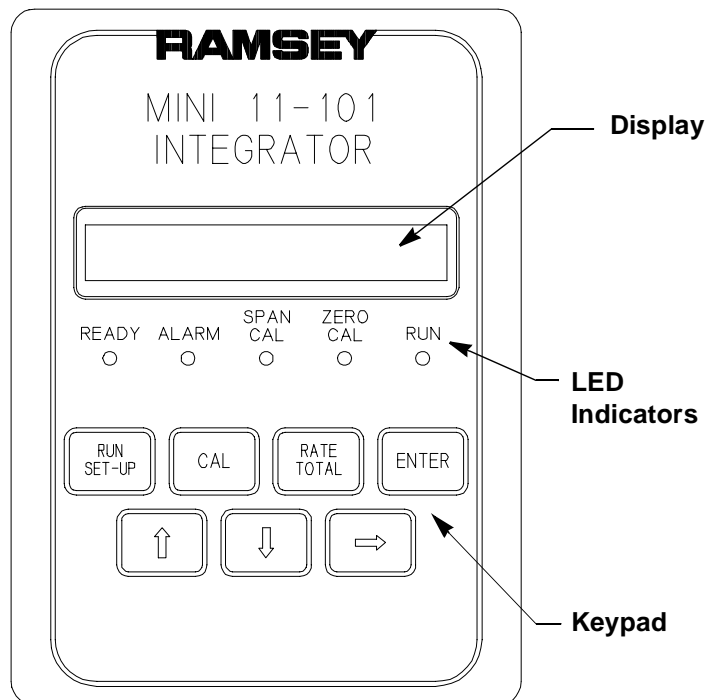

A01652

1.3.5.2 Display

The single-line by 16-character alphanumeric display shows actual run-time information or shows the menus used for Mini 11-101F setup, calibration, and testing.

1.3.5.3 LED Indicators

The five red LED indicators across the middle of the front panel show the current *operating status* of the Mini 11-101F. When lit, these indicators mean:

- **READY** - Integrator power is on, the scale is calibrated, and no failure has occurred
- **ALARM** - An integrator alarm or failure has occurred
- **SPAN CAL** - Flashes during a span calibration
- **ZERO CAL** - Flashes during a zero calibration
- **RUN** - The belt is running

1.3.5.4 Keypad

The front panel keypad has seven multifunctional keys that are used for all data entry, setup, and calibrations on the Mini 11-101F.

- **RUN/SET-UP** - Switches the Mini 11-101F between normal Run mode and Setup mode.
- **CAL** - Puts the Mini 11-101F into Calibration mode.
- **RATE/TOTAL** - Switches the Run Menu display among Rate, Master Total, Reset Total, Alarms, and (if installed) Print.
- **ENTER** - The function of this key varies. Pressing **ENTER**:
 - Moves down one level when in Setup mode and opens the main menus.
 - Opens a field for data entry
 - Confirms a newly-entered value
- **↑** - The function of this key varies. Pressing **↑** arrow key:
 - Moves up one level when in Setup mode
 - Scrolls selections within Setup menus
 - Scrolls up digits for numerical data entry
- **↓** - The function of this key varies. Pressing the **↓** arrow key:
 - Scrolls selections at the same level when in Setup mode
 - Scrolls selections within Setup menus
 - Scrolls down digits for numerical data entry
- **→** - Pressing the **→** arrow key moves the cursor to the next digit in numerical entries.

NOTE

Numbers produced by pressing the arrow keys are not actually “entered” into a field until you press the **ENTER** soft key to confirm.

1.4 Menu Structure

The operator interface to the Mini 11-101F is based on a menu structure that guides you through all setup and calibration activities and all operations and maintenance after the integrator has been configured.

All main system menus are similar in appearance and operate in a similar manner. (See *Appendix A* for a full display of the menu items.)

1.5 Data Entry

The Mini 11-101F Integrator is a menu driven machine that allows you to access all set-up, test, and calibration parameters through the keypad.

Set-up menus can be accessed by pressing the **RUN/SET-UP** key. After pressing the key, the first set-up menu (**PROTECTION**) should appear. The set-up menus are:

- **PROTECTION**
- **SCALE DATA**
- **CAL (CALIBRATION) DATA**
- **I/O (INPUT/OUTPUT) DATA**
- **ALARMS**
- **PRINT (OPTIONAL)**
- **TEST**

For initial set-up and calibrating, only **SCALE DATA**, **CAL (calibration) DATA** and **I/O DATA** need to be completed.

NOTE

Consult *Appendix A* for a complete list of menu items to include descriptions and minimum/maximum values. Consult *Appendix B* for a menu tree with an overall view of menu items.

1.5.1 Navigating the Menus

The rules for navigating the menus are as follows:

1. To move down one level, use the **ENTER** key.
2. To move up one level, use the **↑** key.
3. To scroll at the same level, use the **↓** key.

1.5.2 Entering Numbers

To enter or change numbers use the following procedure:

1. Press **ENTER**
The number displays with all the digits
2. Press **←** to position the cursor at the digit to be changed.
3. Use the **↑** and **↓** keys to scroll to the desired number.
4. Repeat Step 1 and 2 until all required digits have been changed.
5. Press **ENTER** to confirm and save the changes.
6. Press **RUN/SET-UP** to return to Run mode.

1.5.3 Selecting Default Values or Changing a Value Selection

To change a previous selection or the default follow these procedures:

1. Press **ENTER**
The current selection is displayed.
2. Press **ENTER** a second time and the display flashes.
3. Use the **↑** and **↓** keys to scroll to the desired selection.
4. Press **ENTER** to confirm and save the selection.
5. Press **RUN/SET-UP** to return to Run mode.

1.6 Technical Specifications

This section lists the technical specifications for the Mini 11-101F Field Mount Integrator.

Enclosure - Field Mount

Dimensions:

Height: 11.81 in. (300 mm)

Width: 9.84 in. (250 mm)

Depth: 6.30 in. (160 mm)

Weight:

8.8 lb (4 kg)

Material:

Polyester, molded, gray

Acrylic door window

Protection:

IP 65 (NEMA 4) dust and low-pressure watertight

Other:

Two-position mounting feet

Triangular door lock

Environmental Conditions

Location:

Indoor/outdoor, without being exposed to excessive heat, moisture or vibration

Can be mounted up to 3,000 ft (914 m) from the load cell(s)

Temperature:

Operating: 14 to 122 °F (–10 to 50 °C)

Storage: –4 to 158 °F (–20 to 70 °C)

Relative Humidity:

Up to 90% non-condensing

Power Requirements

Nominal Voltage:

110 or 220 VAC, selectable

Nominal Frequency:

50/60 Hz

Operating Range (nominal voltage +10%, –15%):

95.5–121 VAC (110 VAC nom.)

187–242 VAC (220 VAC nom.)

Power Consumption:

15 VA maximum

Fusing:

L1 side of line

1.0 A, Slo-Blo, 110 VAC, 5 × 20 mm

0.5 A, Slo-Blo, 220 VAC, 5 × 20 mm

Power Switch:

Switches both L1 (line) and L2 (neutral)

Load Cell

Number:

Up to four 350 Ω load cells in parallel

Cable Distance:

\leq 200 ft without sensing

201 to 3,000 ft: local or remote sense required, jumper selectable

Cable:

\leq 200 ft: 4 conductor, shielded, 16 AWG (Belden #8407 or equivalent)

201 to 3,000 ft: 6 conductor, shielded, 20 AWG (Belden #9260 or equivalent)

Excitation:

10 VDC \pm 0.5% @ 120 mA maximum

Sensitivity:

1.0–3.5 mV/V (selectable)

Input Signal:

35 mV

Input Impedance:

700 Ω minimum

Maximum Usable Signal:

114% of 3 mV/V

Digital Speed Sensor Input

Comparator-based input with hysteresis

Optically isolated

Built-in electrical current source for dry contact type

Power:

+14 VDC

Frequency Range:

Voltage/electrical current type sensor: 0.25–2.0 kHz

Contact closure type sensor: 0.25–30 Hz

Low Threshold:

+1.0 VDC minimum

High Threshold:

+3.2 VDC maximum

Low or High Pulse Duration:

Voltage/electrical current type sensor: 200 μ s minimum

Contact closure type sensor: 15 ms minimum

Hysteresis:

0.5 VDC minimum

Input Impedance:

10 k Ω typical, 500 Ω minimum

Maximum Non-destructive Input Voltage:

\pm 50 V peak, continuous

Figure 1-3. Logic Diagram - Speed Sensor Input

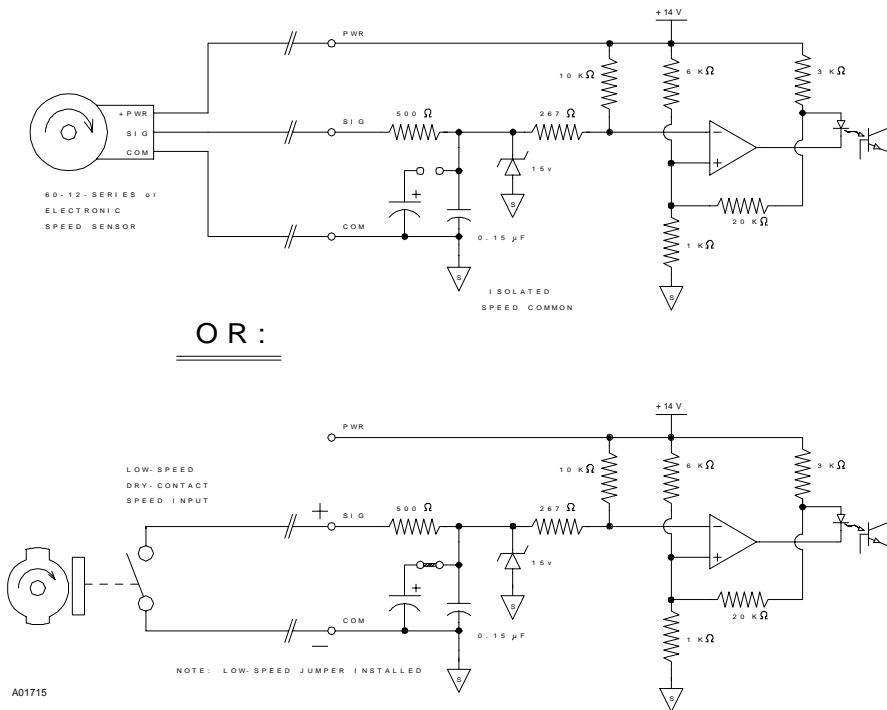

General Purpose Digital Inputs

Quantity:

Three

Type:

Static, for dry contact or open collector

Insulation:

Optical, 2,500 Vrms (UL E67349)

Voltage:

14 VDC (internal source available)

Electrical Current:

6 mA

Figure 1-4. Logic Diagram -
General Purpose Digital Inputs
2, 3, and 4

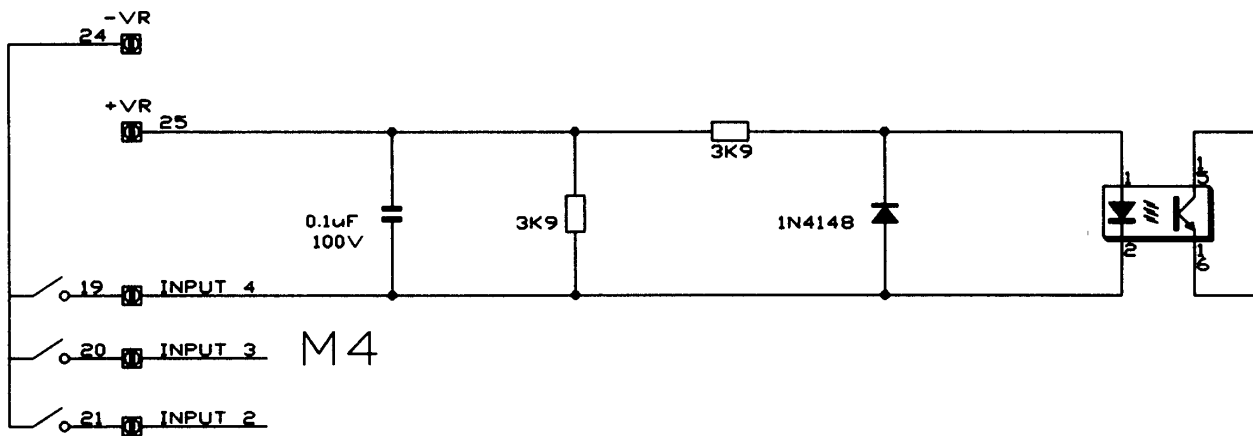

A01176

General Purpose Digital Outputs

Quantity:

Four

Type:

Relay, dry contact, normally open (NO)

Insulation:

Galvanic, 10,000 M Ω

Voltage:

Maximum 240 V AC, 48 V DC

Electrical Current:

Maximum 0.5 A

Figure 1-5. Relay Outputs

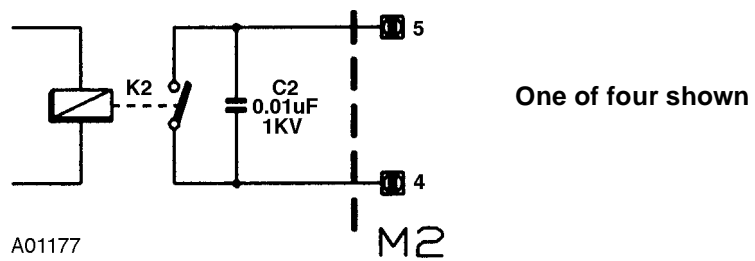

Analog Input

Millivolt signal from load cell(s)

Analog Output

Quantity:

One

Type:

Selectable: 0–20 mA, 4–20 mA, 20–0 mA, 20–4 mA

Maximum Load:

500 Ω

Resolution:

12 bit (4,096 divisions)

Linearity:

0.1%

Insulation:

Galvanic, 1,500 Vrms

Figure 1-6. Logic Diagram:
High-Level Analog Output

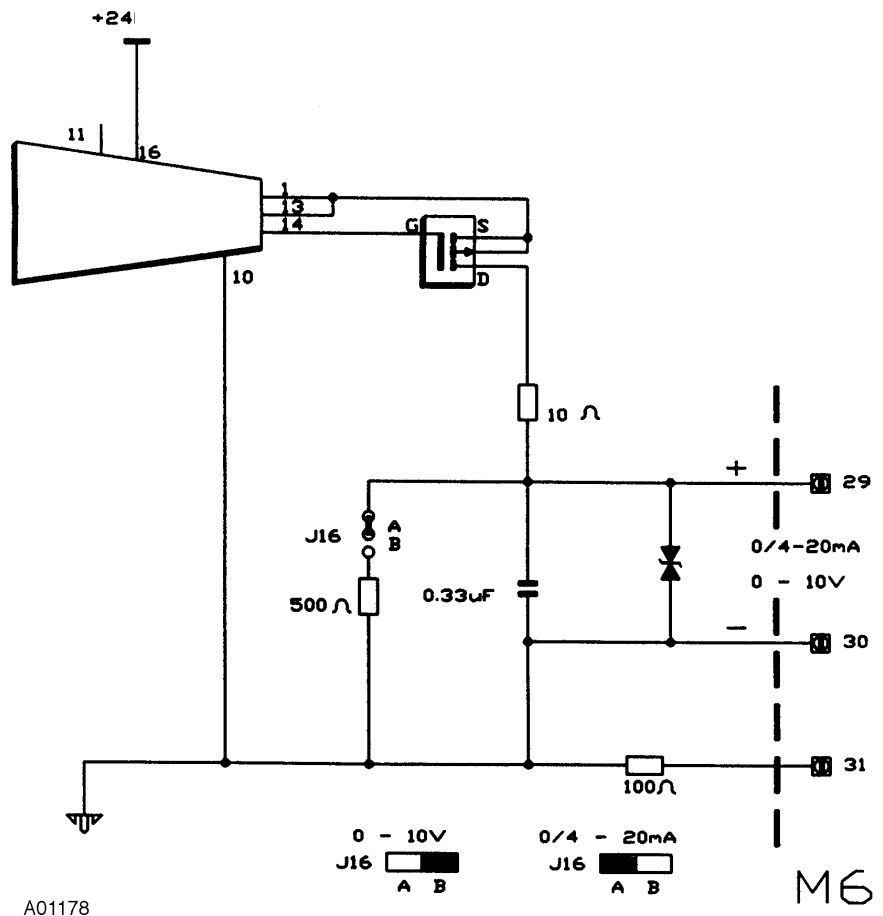

A01178

M6

Printer Port

Quantity:

One

Type:

RS-232C/423

Null modem (Ready/Busy Signal)

Wire Connections:

Terminal Block

Signals:

TX, RX, CTS, RTS

Speed:

1200, 2400, 4800, 9600, 19200, 38400 baud (selectable)

Word Length:

7, 8 bits (selectable)

Stop Bits:

1, 2 bits (selectable)

Parity:

Odd, Even, None (selectable)

Figure 1-7. Signal Connections:
Printer Option

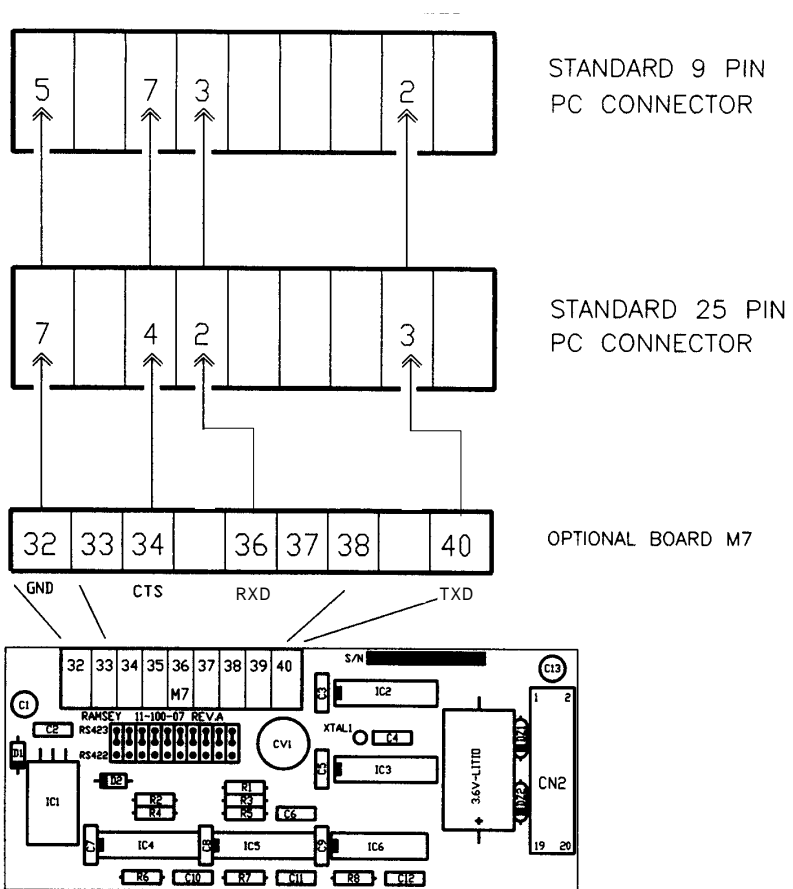

A01179

Chapter 2

Installing and Setting Up the Mini 11-101F Integrator

This chapter provides information about installing and setting up the Mini 11-101F. It discusses installation considerations, provides procedures for mounting and wiring, describes the hardware configuration, and provides procedures for determining initial setup parameters for the device.

2.1 Overview

The customer is responsible for initial inspection of the equipment and for site preparation. It is essential that the equipment be placed on the production line in accordance with the guidelines set forth in this chapter.

The customer must ensure that qualified personnel are available to make interconnections with other production equipment and perform work at the installation site. A customer service representative is available to assist with installation and verify operation as well as train personnel assigned to operate and maintain the equipment.

2.2 Installation Considerations

Do *not* connect power to the machine or turn on the unit until you have read and understood this entire chapter. The precautions and procedures presented in this chapter must be followed carefully to prevent equipment damage and protect you from possible injury.

 **WARNING**

Failure to follow safe installation and servicing procedures could result in death or serious injury.

- Make sure only qualified personnel perform installation and maintenance procedures in accordance with the instructions in this manual.
- Allow only qualified electricians to open and work in the electronics cabinets, power supply cabinets, control cabinets, or switch boxes.

2.2.1 Equipment Location

The Mini 11-101F Integrator mounting site should be selected with care. The enclosure should be mounted as close to the load cell as possible without being exposed to excessive vibration, heat, and moisture.

- The Mini 11-101F may be mounted up to 3,000 ft from the speed sensor.
- The unit should be in a control room environment where it will not be exposed to excessive vibration, heat, cold, or moisture.
- Mount the unit at a height that makes it convenient to use the operator interface front panel.
- Make sure there is enough room to open the enclosure door and lift the chassis cover.

2.2.2 Environmental Factors

The Mini 11-101F Integrator is designed to operate in an environment where the temperature ranges no lower than 14 °F (–10 °C) and no higher than 122 °F (40 °C).

The instrument will operate in an environment where the humidity ranges from 0–90%.

2.2.3 Input Power Requirements

The Mini 11-101F Integrator is factory configured at 110 VAC.

Nominal Voltage	Operating Range	Fusing	Power Consumption	Nominal Frequency
110 VAC	+10%–15%	1.0 A	15 VA	50/60 Hz
220 VAC	+10%–15%	.5 A	15 VA	50/60 Hz

2.2.4 Safety Precautions

⚠ WARNING
<p>Failure to follow safe installation and servicing procedures could result in death or serious injury.</p> <ul style="list-style-type: none"> • Make sure only qualified personnel perform installation and maintenance procedures in accordance with the instruction in this manual. • Allow only qualified electricians to open and work in the electronics cabinets, power supply cabinets, control cabinets, or switch boxes.

⚠ WARNING

High voltage that may be present on leads could cause electrical shock.

- Disconnect incoming power at mains before beginning any installation or wiring procedures.
- Use extreme caution when testing in, on, or around the electronics, PC boards, or modules. There are voltages in excess of 115 V or 230 V in these areas.
- Covers over the electronics should always remain in place during operation. Remove only for maintenance procedures with the machine's power OFF. Replace all covers before resuming operation.

⚠ CAUTION

All wiring must be done in accordance with field wiring diagrams, applicable sections of the National Electrical Code, and local electrical codes.

⚠ CAUTION

Keep hands and clothing away from all moving or rotating parts.

⚠ CAUTION

Do not place or store objects of any kind on this unit.

2.3 Equipment Handling

The Mini 11-101F Integrator is normally sealed in foam which is then packaged in a cardboard carton. This carton should be handled manually.

Lift the carton observing the "This Side Up" labels. Do *not* use hooks. Use extreme caution when handling this equipment because it is extremely delicate.

2.4 Storing the Mini 11-101F

If you are not going to install the Mini 11-101F Integrator now, it can be safely stored, with cover latches secured and hole plugs installed, at temperatures from -20° to $+158^{\circ}$ F (-20° to $+70^{\circ}$ C). Protect the instrument from moisture.

2.5 Inspection and Unpacking

The Mini 11-101F Integrator has been properly packaged at the factory for shipment and storage. Inspect all packages for damage *before* opening. If there is any evidence of shipping damage, notify the shipping carrier immediately; the carrier may be responsible for the damage.

Refer to the appropriate supplemental manual for inspection and unpacking procedures for optional equipment.

2.6 Installing the Mini 11-101F

This section describes how to install the Mini 11-101F Integrator. It includes procedures for mounting, field wiring, and connecting incoming power to a field mount Mini 11-101F.

2.6.1 Site Selection

The ideal mounting location would be on a separate wall or beam in view of the scale. (See *Figure 2-1*) In some applications, it may be necessary to mount the Mini 11-101F Integrator further than 200 feet from the scale. In this instance, a special six-wire shielded cable is required for wiring the load cell and remote excitation sense lines.

Figure 2-1. Typical Integrator Installation

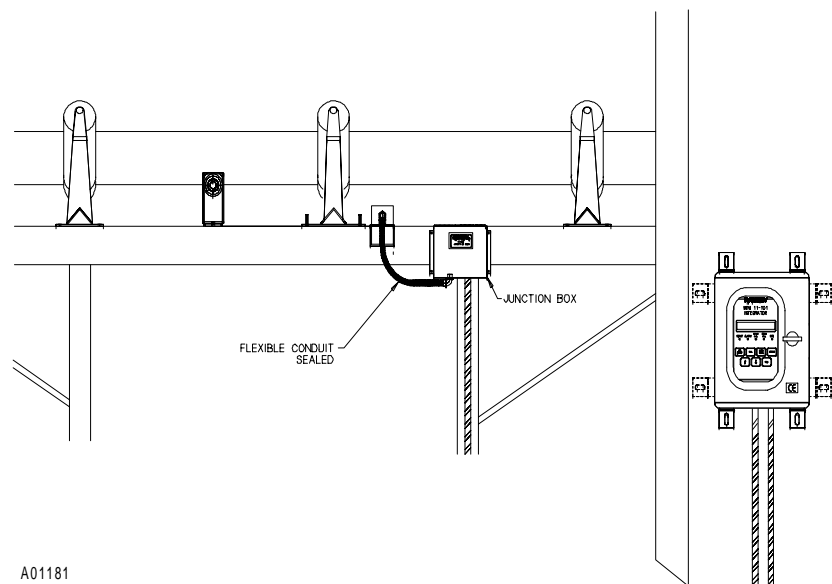

2.6.2 Mounting the Control Unit

Mount the Mini 11-101F Integrator to a rigid fixture in an area of minimum vibration. Mounting dimensions are shown in *Figure 2-2*. The Mini 11-101F Integrator is mounted with the door hinge on the left and at a height which allows comfortable viewing of the displays and access to the front panel, keypad, power switch, and field wiring terminals.



Figure 2-2. Outline and Mounting Dimensions

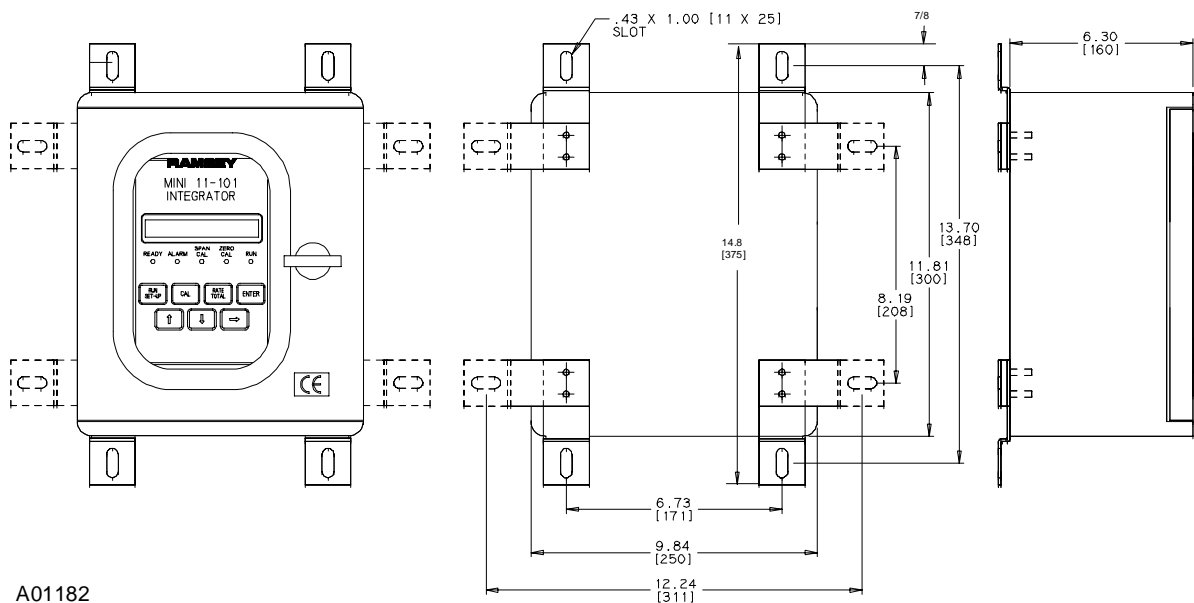

A01182

Follow this procedure to mount the integrator.

1. Bolt the enclosure to a flat, vertical surface using the four mounting holes on the back of the enclosure.
2. Punch the required conduit holes in the bottom of the enclosure for the power supply cable, coil cables, control wiring, communications cable(s), and any additional signal wires and conduit.

Locate the holes in the appropriate areas of the enclosure to separate high and low voltages.

NOTE

All conduit fittings must have grounding terminals. Connect ground to internal chassis.

2.6.3 Wiring the Mini 11-101F Integrator

All wiring, except as noted, is the responsibility of the customer. Follow the field wiring diagram for your system or refer to the *Field Wiring Diagram* in *Appendix C* to connect system wiring

⚠ CAUTION

All wiring must be done in accordance with field wiring diagrams, (see *Appendix C*) the National Electrical Code, and all local electrical codes.

Do not route coil cables through the same conduit with power cables or any large source of electrical noise.

2.6.3.1 Critical Wiring Conditions

Be sure to observe the following critical wiring conditions to ensure proper connection of your detector:

- Ensure main power is OFF.
- Earth ground all enclosures and conduits. A ground connection between all conduits is required.
- Connect the shields ONLY where shown.
- Check that all wires are tight in their connections.
- Never use a “megger” to check the wiring.
- All conduits should enter the bottom of the enclosure. Do not run conduit through the top or sides of the enclosure.
- Do not alter the length of cable supplied with the load cell.
- Use 4 conductor, 16 AWG, shielded if total distance from the scale is 200 feet or less.
- Use 6 conductor, 20 AWG, shielded if total distance from the scale is 201 to 3000 feet.
- If multiple load cells are used, terminate load cell cables at the same points in the scale junction box.

2.6.3.2 Field Wiring Procedure

Follow all cable number specifications on the *Field Wiring Diagram* when connecting wiring to the mother board. Use this procedure to wire the control unit.

1. Route incoming connections through the conduit hole in the bottom of the enclosure.
2. Leave enough loose wiring (about 8 in.) to allow wires to be moved without having to be disconnected.
3. Connect all alarm and indicator output wiring to the appropriate terminals on terminal block M2.
4. Connect the load cell and speed sensor to the appropriate terminals on M3 and M4. The communication cables are directly connected to the communication board. (M7)

2.6.3.3 Connecting Power to the Unit

⚠ CAUTION

Do not apply power until you have read and understood this entire section. Improper connection may result in damage to your integrator.

- Verify that the input voltage is correct with a voltmeter before you connect it to the unit. The red tag attached to the machine specifies the correct input voltage for your particular unit.

Follow this procedure to connect incoming power to the integrator (see *Figure 2-3*).

1. Route incoming power wiring through a conduit hole on the bottom of the enclosure.
2. Connect line power to terminal strip M1 located on the input power module.
3. Leave enough loose wiring (about 8 in.) to allow wires to be moved without having to be disconnected.
4. Wire the safety ground terminal located on the right inside of the chassis.
5. Wire the HOT input power to the M1 terminal labeled L2.
6. Wire the NEUTRAL input power to the M1 terminal labeled N1.
7. Wire the ground to the M1 terminal labeled E3 (earth).

Figure 2-3. Input Power Connections

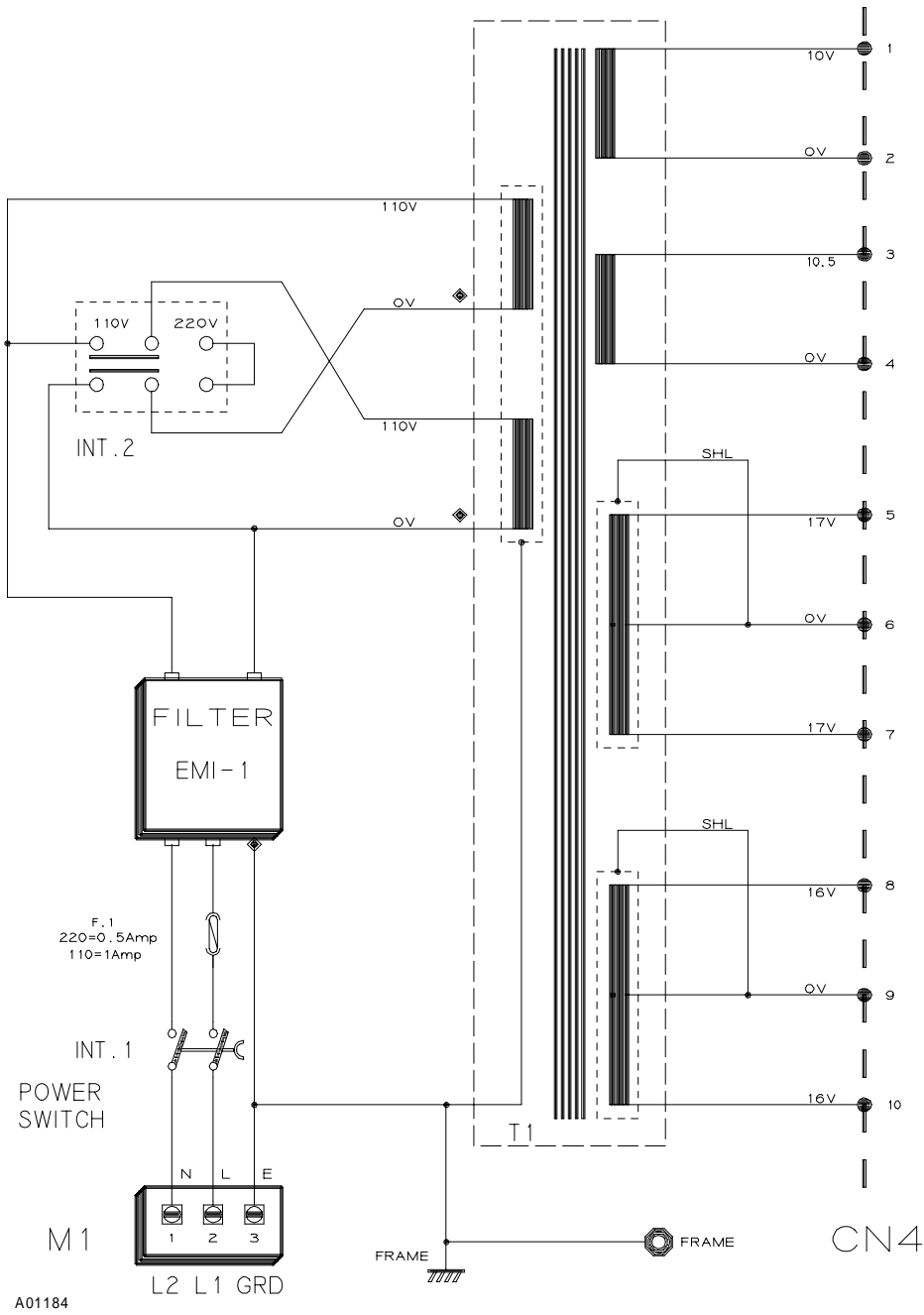

2.7 Configuring the Mini 11-101F Integrator

The Mini 11-101F Integrator is normally factory configured to the customer's specification. This section explains those configurations and the option you have to change selections.

2.8 Input Power Selection Switches

Switches and removable jumpers are described in this section. The default position is noted in each description and, in most cases, is not changed.

- 110 or 220 VAC is switch selectable by INT2 located on the input power module (see *Figure 2-3*).

Default: 110 VAC

- 50 or 60 Hz is switch selectable SW1 located in the center of the mother board (*Figure 2-4*) 50 Hz is the closed position and 60 Hz is the open position.

Default: 60 Hz

- Speed input selection is controlled by jumper selectable J13 located on the lower, right hand center section of the mother board.

Default: position 'A' for speed inputs from Model 60-xx or 60-xxx Speed Sensors.

Figure 2-4. Mother Board

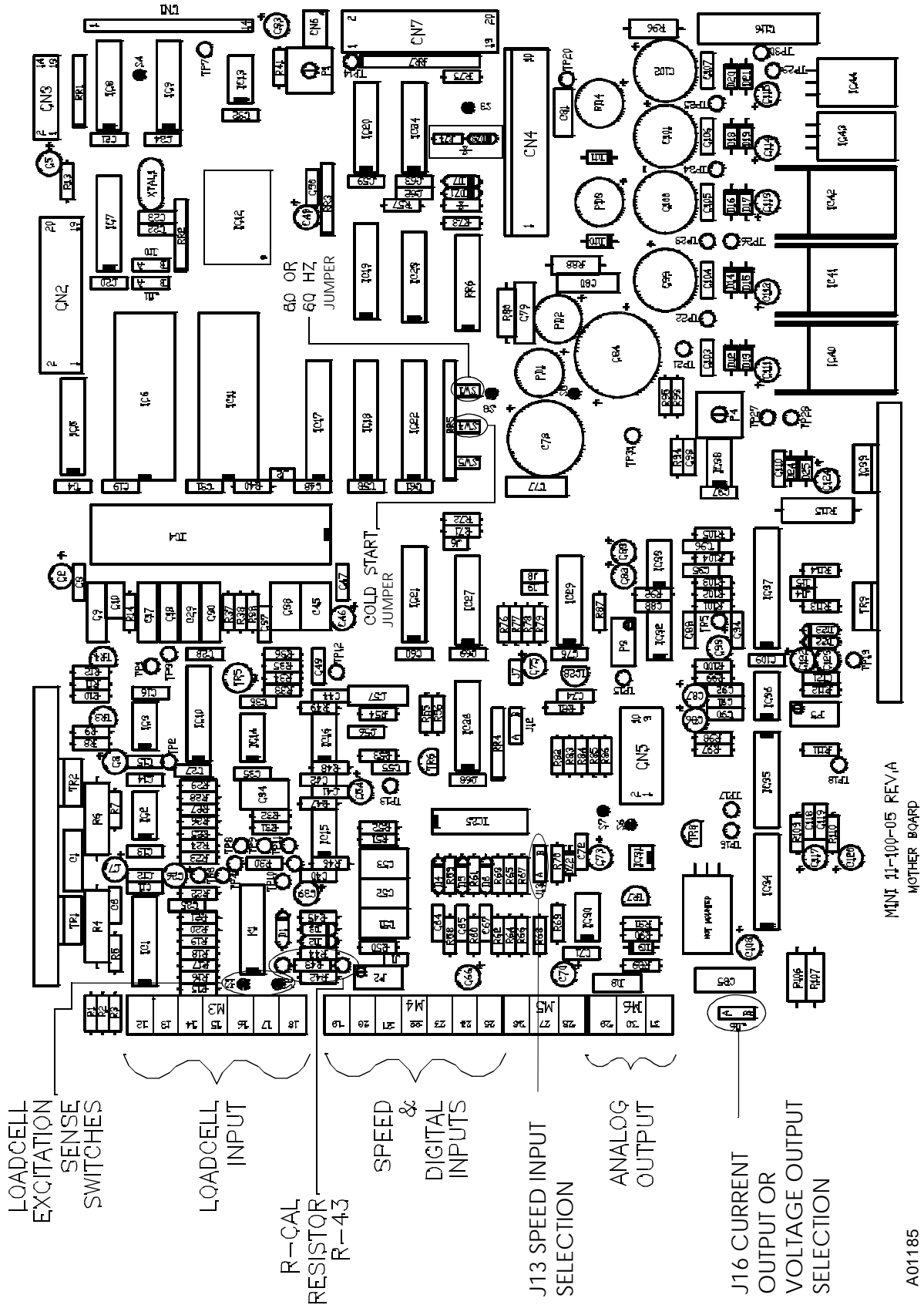

2.8.1 Load Cell Sense

If the distance between the load cell(s) and the Mini 11-101F is less than 200 feet, the load cell(s) are to be terminated with 4 conductor cable. The sensing of the excitation voltage is handled internally in the Integrator.

When distances are between 200 and 3000 feet, six conductor cable is required. The sense leads and excitation is jumpered in the scale junction box (generally located within 20 feet of the load cell).

2.8.2 General Purpose Digital Input Configuration

There are three user definable, general purpose digital inputs on the relay board. These inputs are optically isolated, dry contact type configured N.O., 0.5 Amp at 250 VAC (see *Figure 2-5*).

The power supply for the general purpose digital inputs is a +14 V unregulated DC supply.

The user definable input choices are:

- Not Used – Default No. 4 Input
- Clear Total – Default No. 2 Input
- Belt Running
- Clear Alarms – Default No. 3 Input
- Auto Zero
- Print – Requires optional communication board
- CAL Switch used during calibration

Figure 2-5. Relay Board

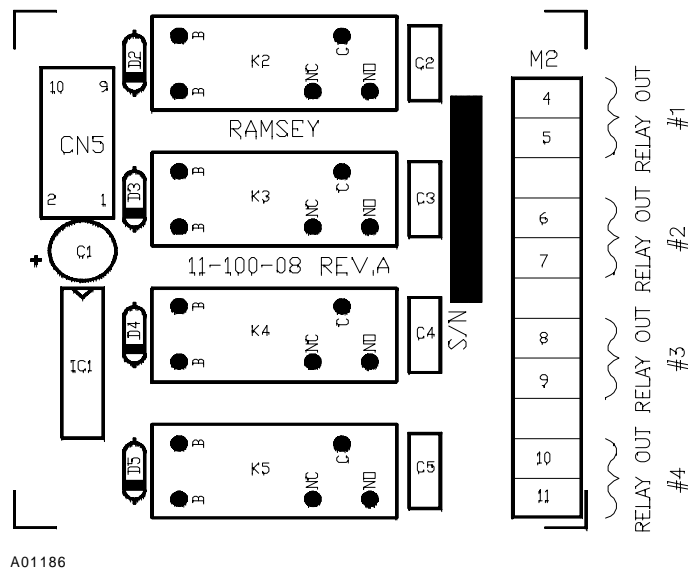

A01186

2.8.3 General Purpose Digital Output Configuration

There are four user definable, general purpose, digital outputs on the relay board. These inputs are optically isolated, dry contact type configured normally open (*Figure 2-5*). The maximum voltage is 240 VAC or 48 VDC, .5A.

The user definable output choices are:

- Not Used – Default
- Alarm – Default No. 2 Output
- Instrument Ready – Default No. 1 Output
- Low Rate
- High Rate – Default No. 4 Output
- Totalizer – Default No. 3 Output
- Fail

2.8.4 Analog Output Configuration

One jumper selectable flow rate analog output is available. Jumper J16, located on the bottom right hand side of the mother board, selects between electrical current or voltage output (see *Figure 2-4*).

Available selections are:

Analog Output	J16
4-20 MA	“A” Default
20-0 MA	
20-4 MA	
0-20 MA	
0-10 VDC	“B”

2.8.5 Optional Print Configuration

The print option requires the optional RS-232C/RS-423 communication board. The board is installed on the left hand side of the Mini 11-101F Integrator enclosure.

The settings for jumpers J2–J11 on the communication board for RS-232 or RS-423 must be set to the B position.

For RS-422, jumpers J2–J11 must be set to the A position. Default setting is the B position (see *Figure 2-6*.)

Figure 2-6. Communication Board

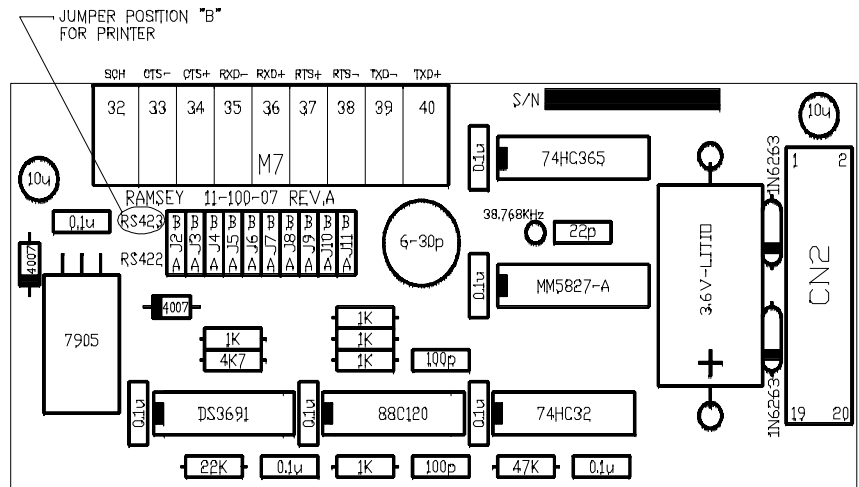

A01187

2.9 Powering Up the Mini 11-101F Integrator

⚠ CAUTION

Before applying power, check the 110/220 VAC slide selector switch to make sure it is in the correct position for available power.

After the integrator has been properly mounted, wired and configured power up the unit by turning on the main power.

The integrator powers up using values that were pre-programmed at the factory.

It is recommended the integrator is cold started (original factory defaults installed) prior to beginning the initial setup procedure. Refer to *4.5.4 Cold Start Procedure*.

2.10 Initial Set Up and Programming

If you are unfamiliar with the front panel layout, the keys and their functions, or how to enter data, please refer to *Figure 1.2* and Section *1.5 Data Entry*. Multifunctional keys and scroll keys ↓ on the integrator front panel are used to enter data and select choices on the setup menus.

Before calibrating the belt scale, the parameters recorded in Section *2.10.2 Recording Installation Parameters* must be entered. After all the data is entered, the integrator automatically calculates an R-Cal *calibration constant (Calcon)* during the acquire test duration procedure.

2.10.1 Selecting the Language

At this menu you can select the language to use with the Mini 11-101F Integrator. This menu option is found in the Input/Output menu. The choices for language are English or Spanish.

1. Press **RUN/SET-UP**
PROTECTION displays
2. Press ↓ until I/O DATA displays
3. Press **ENTER**
4. Press ↓ until LANGUAGE displays
5. Press **ENTER**
The default setting displays and flashes (default =English), press **ENTER** again
6. Scroll to make your selection.
7. Press **ENTER** to confirm your choice.
8. Press **RUN/SET-UP** to return to Run mode

2.10.2 Recording Installation Parameters

Following mechanical and electrical installation, you need to enter scale and calibration data specific to your installation. Determine the following installation parameters for your system and enter them in the last field of table *Installation Parameters on page 2 - 15* before proceeding with integrator programming and belt scale calibration.

Table 2-1. Installation Parameters

Parameter	Definition	Scroll Setting Value
Scale Capacity	Determine the scale's capacity in English units (TPH, LB/HR, KG/HR)	
Load Cell Capacity	The load cell capacity is marked on the end of the load cell cable. The load cell capacity may be in pounds (lb) or kilograms (kg). Record the capacity of <i>only one</i> load cell.	
Number of Load Cells	Enter the total number of load cells in the weigh bridge.	
Load Cell Sensitivity (Cell mV/V)	Record the load cell sensitivity. Value is listed on the Scale Data Sheet. <ul style="list-style-type: none"> • 10-101R Scale = 2.0 mV/v • 10-30 Scale = 1.8 mV/v • 10-20 Scale = 3.0 mV/v 	
Load Cell Resistance	The load cell resistance is indicated on the end of the load cell cable. Enter the resistance in ohms. For multiple module scales, enter the parallel resistance for the load cells. To calculate load cell resistance use the following formula: $LCRES = (R_1 \times R_2 \times R_x) \div (R_1 + R_2 + R_x)$	
Lever Ratio	The lever ratio is the ratio between the weigh idler and the load cell. Ratios for the three most common belt scales are: 10-101R, all widths = 1.0 10-20-1, 18" to 36" width = 1.333 10-20-1, 42" to 72" width = 1.407 10-30, all widths = 1.0 As an aid to determining the ratio, use the following: pivot to load cell \div pivot to weigh idler	

Parameter	Definition	Scroll Setting Value
Idler Spacing Scale Area	<p>Measure the distances between the center lines of the plus 1 (+1) and minus 1(-1) idlers on both sides of the conveyor (left and right). Add the two measurements together and divide by 4. Record the spacing in feet or meters. Fractions must be entered as decimal equivalents.</p> <p>If the two distances measured are not equal to each other within a 0.032 inch (1/32"), the scale is not properly installed. Refer to the belt scale installation manual provided.</p>	
Number of Weigh Idlers	In most instances there is only one weigh idler.	
Conveyor's Angle of Incline	<p>Measure the conveyor's angle of incline to the nearest 0.1 degree. Record the degree of the angle.</p> <p>Refer to <i>Figure 2-7</i> for information on how to measure the angle of an incline.</p>	
Conveyor Belt Length	Using a long tape measure, measure the entire length of the belt. Measure to the nearest 0.1 foot.	
Conveyor Belt Revolutions	<p>To calculate belt revolution, the belt must first make a minimum of three revolutions and have a six minute runtime.</p> <p>Determine the time necessary (in seconds) for the belt to make one complete revolution. Record the number of revolutions to use for calibration test length.</p>	
Test Length	<p>The test duration uses the test length during setup.</p> <p>Test Length = Belt Length x number of test revolutions. (TL = BL x Rev's)</p>	
Test Weights	<p>If static test weights were supplied with the scale, enter that total weight in pounds.</p> <p>The total weight is stamped on the test weight or test weight actuator.</p>	

Figure 2-7. Measuring the Angle of Incline

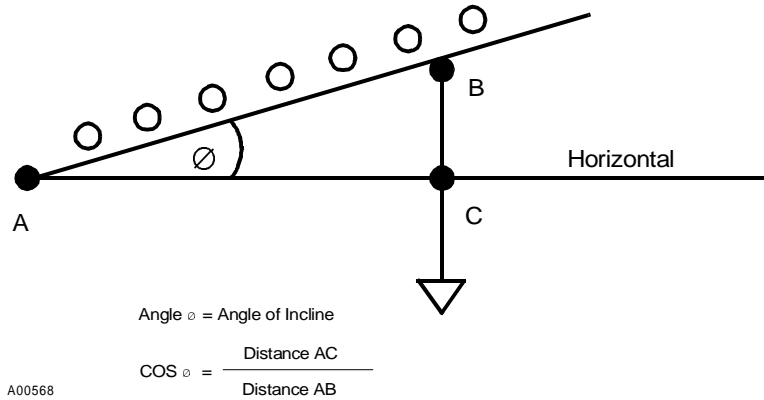

- Choose a convenient distance AB and measure it in inches.
- Hang a plumb line from B.
- Measure the horizontal distance from A to plumb line in inches (AC). Divide AC by AB to get COS \emptyset .
- If the angle of incline in degrees is known, use the following table.

Angle \emptyset	COS \emptyset	COS \emptyset	Angle \emptyset	Angle \emptyset	COS \emptyset
0	1.000	6	.9945	12	.9781
1	.9998	7	.9925	13	.9744
2	.9994	8	.9903	14	.9703
3	.9986	9	.9877	15	.9659
4	.9976	10	.9848	16	.9613
5	.9962	11	.9816	17	.9563

2.10.3 Specifying Scale Data During Set-Up

The Mini 11-101F Integrator must be configured to your operating parameters. Several of these are recorded in [Table 2-1](#).

If you are unsure or unfamiliar with how to enter data or navigate the menus from the integrator front panel, refer to [Data Entry on page 1 - 10](#).

If you enter a value for a setup parameter that is outside of the valid range, the system displays an error message indicating the error. You must re-enter the data.

NOTE

Turn the belt scale conveyor belt on. Run the conveyor empty during set-up and calibration.

If you choose to use any default settings or there are no changes to be made to a specific menu item, press  to scroll to the next menu item.

1. Press **RUN/SETUP**
PROTECTION displays
2. Press **↓**
SCALE DATA displays
3. Press **ENTER**
SCALE UNITS displays

The selections used during this set-up procedure are listed below. Press **↓** to move from one menu item to the next.

- SCALE UNITS
- DECIMAL PLACE
- SCALE CAPACITY
- LCELL CAP
- CELLS NUMBER

There are other menu items in the scale data menu. It is not necessary at this time to enter Low Rate Set, High Rate Set, Rate Alarm Delay, AZT Range, Limit AZT, and Deadband. These entries can be made at any time after initial setup and calibration.

2.10.3.1 Scale Units

Scale units are the units used to display the master total. When you select a scale unit, you also select the units used for the rate display. Default scale units are Tons. Rates are in units/hour. Scroll to **SCALE UNITS** and select the units you are using for your particular scale.

The default setting for **SCALE UNITS** is Tons. Available selections for **SCALE UNITS** and the way they are displayed are listed below.

Units	Display	Weight	Length	Rate
Pounds	Lb	Lb	ft	Lb/h
Tons	TON	Lb	ft	TPH
Long Tons	LTN	Lb	ft	LTph
tons	t	kg	m	t/h
kg	kg	kg	m	kg/h

Follow this procedure to change the default value of the **SCALE UNITS**.

1. With **SCALE UNITS** displayed, press **ENTER**
The default value displays
2. Press **ENTER**
The display flashes

3. Press **↓** to scroll to the units used for your setup
4. Press **ENTER** to save your selection
5. Press **↓** to move to the next menu item

NOTE

If the LED display continues to flash, press **ENTER** until the flashing stops. Selections are *not* saved until the LED stops flashing.

2.10.3.2 Decimal Place

The **DECIMAL PLACE** menu lets you choose the number of decimal places to be displayed. Select the number of decimals. The default value for the **DECIMAL PLACE** is 1.

Follow this procedure to change the default **DECIMAL PLACE** setting.

1. Press **ENTER**
Decimal setting displays
2. Press **ENTER**
The display flashes
3. Press either of the arrow keys until the decimal is located where you want it.

NOTE

During zero and span calibration, the resolution of the displayed total is 10 times greater than it normally would be.

4. Press **ENTER** to save your selection.
5. Press **↓** to move to the next menu item
Min: 0
Max: 3 (.000)
Default: 1 (.0)

2.10.3.3 Scale Capacity

At the **SCALE CAPACITY** menu enter the capacity of your scale in weight/hour. The default value for **SCALE CAPACITY** is 200.0. Use the following procedures to change the default value.

1. With **SCALE CAPACITY** displayed, press **ENTER**
2. Press **ENTER**
The display flashes
3. Press the arrow keys to enter your scale capacity.
4. Press **ENTER** to save your selection
5. Press **↓** to move to the next menu item.

Min: 1.0
Max: 100,000.0
Default: 200.0

2.10.3.4 Load Cell Capacity

Enter the load cell capacity on the **LCELL CAP** menu. Enter the capacity of *only* one load cell. All load cells will be the same size. Use the following procedures to enter the load cell capacity.

1. With **LCELL CAP** displayed, press **ENTER**
2. Press **ENTER**
The display flashes
3. Press the arrow keys to enter the load cell capacity.
4. Press **ENTER** to save your selection
5. Press **↓** to move to the next menu item.

Min: 10.00
Max: 15000.00
Default: 250.00

NOTE

If the unit measure of the load cell is tons (Tons) or pounds (Lb), then the display cell size is pounds (Lb). If the unit of measure is tons (t/metric ton) or kilograms (kg) the display cell size is kilograms (kg). (Convert as necessary 1 kg = 2.2 lb)

2.10.3.5 Number of Load Cells (Cells Number)

If there is more than one load cell being used, enter the total being used on the **CELLS NUMBER** menu. Use the following procedures to enter the number of load cells.

1. With **CELLS NUMBER** displayed, press **ENTER**
2. Press **ENTER**
The display flashes
3. Press the arrow keys to enter the number of load cells.
4. Press **ENTER** to save your selection.
5. Press **RUN/SET-UP** to return the integrator to run mode.

Min: 1

Max: 4

Default: 1

NOTE

See [Appendix A](#) for the remainder of the Scale Data scrolls. They are considered features and are not necessary for initial set up.

2.10.4 Specifying Calibration Data During Set-Up

Using the information gathered and entered in Section 2.8 *Installation Parameters* you will now specify the calibration data. You must perform this step before proceeding to the calibration procedures in Chapter 3.

2.10.4.1 Selecting the Calibration Method

There are two methods of performing an automatic span calibration on the integrator, electronic res (R-Cal) and test weights. Select which method of automatic span calibration you will be using as your normal procedure. The method you select determines the screens that display in the calibration section. If you choose to use weights or chains in the calibration procedure use the following procedure to manually calculate the calcon.

$$ChainCalcon = \frac{\left[\left(\frac{chainlb}{ft}\right)\right]WTL}{K}$$

$$StaticWeightCalcon = \left[\frac{\left(\frac{staticweightlbs}{WS}\right)WTL}{K} \right]$$

Where:

WTL = belt length x revolutions

W.S. = Weigh Span (number of weigh idlers X idler spacing)

$$K = \begin{array}{l} 2000 \text{ lbs} - \text{Standard Ton} \\ 2240 \text{ lbs} - \text{Long Ton} \\ 2204 \text{ lbs} - \text{Metric Ton} \end{array}$$

1. Press the **RUN/SET-UP**
PROTECTION displays
2. Press **↓** until CAL DATA displays
3. Press **ENTER**
The first CAL DATA screen appears.
4. Use the arrow keys to select **WGHT OR CHAINS** or
ELECTRONIC RES
5. Press **ENTER** to save the selection.

NOTE

If the scale carriage is not a 10-101R, a different test weight calcon formula may be required (see [Appendix A](#)).

2.10.4.2 Defining Electronic Res (R-Cal) Parameters

If ELECTRONIC RES has been selected, press the **↓** and follow this procedure to have the system automatically calculate and install the R-Cal calibration constant.

NOTE

If WGHT or CHAINS was selected, skip to Chapter 3, paying special attention to the procedures in Section [3.4.2.2 Auto Span Calibration Using Test Weights or Chains](#).

R-Cal Mode

The integrator automatically calculates and installs the Electronic Res (R-Cal) calibration constant if Automatic Calcon is selected. The following scale parameters must be entered and the belt test length entered in the CAL (Calibration) scroll to enable automatic calculations of the R-Cal calibration constant.

1. Press **↓**, until RCAL MODE displays
2. Press **ENTER**
3. Select the method you wish to use **AUTOMATIC** or **MANUAL**.

Stop here if you selected **MANUAL** calculation. You will have to manually calculate the calibration constant and enter it during the calibration of the Mini 11-101F. (See [Factoring Test Weights/Chains Calcon After Span Calibration With Material on page 3 - 11.](#))

If you select **AUTOMATIC**, complete the remaining steps using the information gathered in [Table 2-1. Installation Parameters](#).

4. Press **↓** to move to the next menu item.

Load Cell Sensitivity

Enter the load cell sensitivity on the CELL MV/V menu. Sensitivity of the load cells used are listed below:

- 10-101R Scale = 2.0 mV/v
- 10-30 Scale = 1.8 mV/v
- 10-20 Scale = 3.0 mV/v

1. CELL MV/V displays
2. Press **ENTER**
The display flashes
3. Press the arrow keys to enter the load cell sensitivity.

NOTE

If you are using two or more load cells, average the sensitivity. Refer to *Table 2-1. Installation Parameters.*

4. Press **ENTER** to save your selection.
5. Press **↓** to move to the next menu item.

Min: 1.000 mV/V

Max: 3.500 mV/V

Default: 1.800 mV/V

Cell Resistance

At CELL RESIST enter the resistance of the load cell(s). The resistance for the load cell has been recorded on the System Data Sheet in the front of your belt scale manual. It is also stamped on the load cell cable. Use the following procedure to enter the load cell resistance.

1. CELLS RESIST displays
2. Press **ENTER**
The display flashes
3. Press the arrow keys to enter the cell resistance.

NOTE

This is the parallel resistance if two or more load cells are used. Refer to *Table 2-1. Installation Parameters.*

4. Press **ENTER** to save your selection.
5. Press **↓** to move to the next menu item.

Min: 50.000 ohms

Max: 1000.000 ohms

Default: 350.000 ohms

Calibration Resistance

Enter the resistance of R43 in ohms of the R-Cal resistor installed in your Mini 11-101F Integrator on the **CALIBRATION RES** menu. See the system data sheet for exact resistance.

1. **CALIBRATION RES** displays
2. Press **ENTER**
The display flashes
3. Press the arrow keys to enter the collaboration resistance.
4. Press **ENTER** to save your selection.
5. Press **↓** to move to the next menu item.

Min: 50,000 ohms

Max: 1000,000 ohms

Default: 165,000 ohms

Lever Ratio

The lever ratio is the ratio between the weigh idler and the load cell. See the scale manual for exact dimensions entered on the **LEVER RATIO** menu. Use the following procedures to enter the lever ratio.

Weighbridge	Ratio
10-101R - All widths	1.0
10-20-1 - 18" to 36" width	1.333
10-20-1 - 42" to 72" width	1.407
10-30 - All widths	1.0

1. **LEVER RATIO** displays
2. Press **ENTER**
The display flashes
3. Press the arrow keys to enter the lever ratio.
4. Press **ENTER** to save your selection.
5. Press **↓** to move to the next menu item.

Min: 0.001

Max: 2.000

Default: 1.000

Idler Spacing

At the IDLER SPACING menu, enter the scale area idler spacing in feet or meters. Fractions cannot be entered. All measurements must be in decimal. Example: 42 ½ inch spacing = 3.542 feet. Use the following procedures to enter the idler spacing.

1. IDLER SPACING displays
2. Press **ENTER**
The display flashes
3. Press the arrow keys to enter the idler spacing.
4. Press **ENTER** to save your selection.
5. Press **↓** to move to the next menu item.

Min: 0.001 ft

Max: 999.999 ft

Default: 3.000 ft

Idlers Number

At the IDLER NUMBER menu, use the following procedures to enter the number of weigh idlers.

1. IDLER NUMBER displays
2. Press **ENTER**
The display flashes
3. Press the arrow keys to enter the number of idlers.
4. Press **ENTER** to save your selection.
5. Press **↓** to move to the next menu item.

Min: 1

Max: 6

Default: 1

Conveyor Angle

At the CONVEYOR ANGLE menu, use the following procedures to enter the belt conveyor's angle of incline.

1. CONVEYOR ANGLE displays
2. Press **ENTER**
The display flashes
3. Press the arrow keys to enter the conveyor angle.
4. Press **ENTER** to save your selection.

5. Press **RUN-SET-UP** to return the integrator to run mode.

Min: -25.0 degrees

Max: +25.0 degrees

Default: 0.0 degrees

NOTE

Automatic calculation is not complete until the *Acquire Test Duration* procedure has been performed.

2.10.5 Acquiring the Test Duration

After entering the constant data, an acquired test duration must be run. On completion, the integrator automatically calculates the R-Cal span calibration constant based on the conveyor and scale data entered. It is not necessary to do another test duration unless the belt length changes substantially or the belt is replaced.

Test Duration is an exact total of pulses from the speed sensor proportional to feet of belt traveled. The belt must be running at maximum speed.

To begin acquiring a test duration, mark a reference point on the belt clearly visible from the integrator, with either crayon or spray paint. Run the conveyor belt at maximum speed with no material or use a stop watch.

1. Press **CAL**

ZERO CALIBRATION displays

2. Press **↓** until TEST DURATION displays

3. Press **ENTER**

LENGTH displays and flashes

4. Press **ENTER**

BELT LENGTH is displayed

5. Enter test length (belt length x test revolutions, refer to *Table 2-1. Installation Parameters*)

Max Length = 10,00.00 ft

Min Length = 1.00 ft

6. Press **ENTER** to save your selection

7. Press **↓** to acquire test duration.

8. Press **ENTER** to start counting when belt mark passes a known reference point.

NOTE

If **POST SPAN** displays before **TEST DURATION** in the menu it is because a calibration with material was done and not completed. Just scroll past this to reach **TEST DURATION**.

9. Count the conveyor belt revolutions.
10. When the number of revolutions, equal to test conveyor belt revolutions as listed in *Table 2-1. Installation Parameters*, passes the reference point, press **ENTER** to stop the counter.

Pulses are displayed, press **ENTER** to acquire.

ACQUIRE displays, which indicates the test duration number has been acquired. The test duration number is used for Auto Zero and Auto Span.

11. Press **RUN/SET-UP** to return to Run mode.

Mini 11-101F Field Mount Integrator

Table 2-2. R-Cal Parameter Overview

Menu Item	Definition	Min	Max	Default										
CALIBRATION MODE	Selects the calibration method and the choices are: <ul style="list-style-type: none"> • Electronic Res (R-Cal) - Default • Weights or Chains 													
RCAL MODE	The integrator automatically calculates and installs the Electronic Res (R-Cal) calibration constant if Automatic Calcon is selected. The scale parameters must be installed and the belt parameters in the Test Duration scroll installed to enable automatic calculations. Available Selections are: <ul style="list-style-type: none"> • Manual calcon • Automatic calcon - Default 													
CELL MV/V	The cell sensitivity in mV/V. The actual sensitivity is listed on the system data sheet.	1.000 mV/V	3.500 mV/V	1.800 mV/V										
CELLS RESIST	The resistance for the load cell has been recorded on the System Data Sheet in the front of your belt scale manual. It is also stamped on the load cell cable. Enter the ohms for the load cell(s).	50.000 ohms	1000.000 ohms	350.000 ohms										
CALIBRATION RES	The resistance in ohms of the R-Cal resistor installed in your integrator. See the System Data Sheet for exact resistance.	50,000 ohms	1,000,000 ohms	165,000 ohms										
LEVER RATIO	The lever ratio is the ratio between the weigh idler and the load cell. See the scale manual for exact dimensions. <table border="0" style="width: 100%;"> <thead> <tr> <th style="text-align: left;">Weighbridge</th> <th style="text-align: left;">Ratio</th> </tr> </thead> <tbody> <tr> <td>10-101R - All widths</td> <td>1.0</td> </tr> <tr> <td>10-20-1 - 18" to 36" width</td> <td>1.333</td> </tr> <tr> <td>10-20-1 - 42" to 72" width</td> <td>1.407</td> </tr> <tr> <td>10-30 - All widths</td> <td>1.</td> </tr> </tbody> </table>	Weighbridge	Ratio	10-101R - All widths	1.0	10-20-1 - 18" to 36" width	1.333	10-20-1 - 42" to 72" width	1.407	10-30 - All widths	1.	0.001	2.000	1.000
Weighbridge	Ratio													
10-101R - All widths	1.0													
10-20-1 - 18" to 36" width	1.333													
10-20-1 - 42" to 72" width	1.407													
10-30 - All widths	1.													
IDLER SPACING	Scale area idler spacing in feet or meters. Fractions cannot be entered. Example: 42 ½" spacing = 3.542 feet	0.001 ft	999.999 ft	3.000 ft										
IDLER NUMBER	The number of weigh idlers	1	6	1										
CONVEYOR ANGLE	The belt conveyor's angle of inclination	-25.0 degrees	+25.0 degrees	0.0 degrees										
CALCON RCAL	The installed R-Cal Calcon can be factored or changed after automatic calculation if desired.	1	999.999	0										

2.10.6 Introduction to Calibration

Once you have programmed the Mini 11-101F with the set-up data, you need to calibrate the instrument. Three calibration procedures must be performed to bring your Mini 11-101F to an operational state.

1. Auto Zero Calibration
2. Span Calibration
3. Post Span Calibration (if the span calibration is performed with weights, chains, or material).

Follow the procedures in Chapter 3 of this manual to calibrate your scale.

Chapter 3

Operating the Mini 11-101F Integrator

This chapter provides operating procedures for the Mini 11-101F Integrator. It includes procedures you can initiate from the Run Menu, calibration procedures, handling alarms, and setting up protection levels.

3.1 Overview

The Mini 11-101F Integrator is a menu-driven machine that allows you to access all setup, test, and calibration parameters from the front panel. You select and display menu scrolls by pressing the function keys (**RUN/SET-UP**, **CAL**, **RATE TOTAL**, and **ENTER**) directly, then using the **↑**, **↓**, and **→** keys on the front panel to enter data. If you are unfamiliar with menu scrolls or data entry refer to [Data Entry on page 1-10](#).

Optional menu scrolls and selections are available only if the option has been installed. If the Mini 11-101F is password protected, you must enter the appropriate password before you will be allowed to make changes or perform routine calibrations. Menus may be viewed without entering the password, but no entries are allowed.

3.2 Run Menu Procedures

This section describes the Mini 11-101F Run Menu and the information that can be displayed on it. It also provides procedures for operations initiated from the Run Menu.

The **RUN** menu is the normal mode of operation. At any time, pressing **RUN/SET-UP** returns the integrator to the Run mode, even if calibration or some other function is in progress.

Scroll viewable run information by pressing **RATE/TOTAL**. The selectable displayed information in the **RUN** menu that can be viewed is:

- **FLOW RATE** - The rate at which bulk material is being conveyed and delivered. This displays while the integrator is operational.
- **MASTER TOTAL** - The aggregate of tons totalized by the Integrator since installation. This number cannot be cleared.

- **RESET TOTAL** - Displays a totalized quantity. You press **ENTER** while the **RESET TOTAL** is on display, the next display states **CLEAR TOTAL?**. Pressing **ENTER** again clears the Reset Total.
- **PRINT TOTAL** - If the optional COMM board is installed a report is printed. The format on the report depends on set up. The default format is as follows:

```

DATE           09-19-00
TIME           02:40:35
RATE           133.5 Ton
MASTER TOTAL   239961.2 Ton
RESET TOTAL    0
    
```

- An optional customer defined report is also available. It includes the above data plus three alphanumeric strings printed in a position the user can define by entering row and column numbers for each item to be printed. (See *A.2.6 Printer Scroll (Optional) Menu*).
- **ALARMS** - This menu item tells you the alarms that are currently pending. When you select **ALARMS** and press **ENTER**, if **NO ALARMS** displays this indicates there are no alarm conditions present.

If one or more alarms exists, an alarm message is displayed for each. Scrolling between alarms is done using the down arrow key.

Each alarm can be reset, if the alarm condition has cleared, by pressing the **ENTER** key when the given alarm message is on the screen. To reset all the alarms, press **ENTER** until the **NO ALARMS** message is displayed.

If pressing **ENTER** does not clear the alarm message, this means the alarm condition still exists.

3.3 Handling Pending Alarms

Table 3-1 details a few of the more common alarm situations and the action to be taken to clear the alarm. This is by no means an all inclusive list, but does cover some of the more common alarm issues.

Table 3-1. Alarm Messages

No.	ALARM	MEANING/ACTION
1	Low Rate	The alarm output becomes active when the material flow rate falls below the preset low limit. Range for low flow alarm is 0%-100% of scale capacity. The default setting is 10%.
2	High Rate	The alarm output becomes active when the material flow rate exceeds the preset high limit. Range for the high flow alarm is 0%-150% of scale capacity. The default setting is 100%

No.	ALARM	MEANING/ACTION
3	Remote Counter Overflow	<p>If the remote counter (pulse output) has lagged behind the master totalizer by more than 250 counts, this alarm will become active. This indicates the output pulse width is too large for the count rate, or the pulse output divide ratio is too small.</p> <p>Example: If the count rate is 5000.0 TPH, the pulse frequency will be 13.88 pulses or counts per second.</p> <p>This means that the maximum time for a complete pulse (on time and off time) cannot exceed 73 ms. If the pulse output pulse width is set to 100 ms, at scale capacity the output buffer would overflow the 250 count limit in about 180 seconds or three minutes. The pulse output should be set to a value less than 72 ms or the output divide ratio set to 10 (each pulse output would represent 1.0 tons instead of the typical .1 ton).</p>
4	Belt Pulse Counter Overflow	<p>The maximum input frequency from a belt speed sensor is 2.0 kHz. A frequency greater than this value cannot be interpreted by the integrator causing a belt pulse overflow alarm.</p>
5	Cold Start	<p>The system has detected the loss of the setup data after power was removed.</p> <ul style="list-style-type: none"> • The instrument needs to be set up and calibrated. • Replace either the mother board or the battery.
6	Load Cell Fail	<p>The system has detected an error on the load cell signal indicating either a negative voltage or an excessively high voltage. (Refer to instrument specifications for limits.) Do the following:</p> <ul style="list-style-type: none"> • Check the load cell connections • Check the load cell • See also 4.5.3 Load Cell Excitation and Signal Voltage
7	Maximum Zero Correction	<p>The maximum allowable change in zero using the Auto Zero function is 10% of scale capacity. A change greater than this amount indicates a major error in the system. Completion of scale area physical inspection and load cell test procedure is recommended. A "Cold Start" and re-calibration of the system may be necessary.</p>
8	Math Error	<p>A divide by zero or overflow error was encountered during internal calculations. This message indicates that some abnormal dimensional parameter has been entered in setup.</p> <ul style="list-style-type: none"> • Check setup data

3.4 Calibrating the Mini 11-101F Integrator

Prior to running a zero or span calibration, several conveyor and scale constants must be entered in the Scale Data and Cal Data Scroll. See *Recording Installation Parameters* on page 2-15 for required entries.

You will need to perform all of the data entry when you are setting up the system. Several constants required for system operation are installed by these initial calibrations.

You will also need to perform the Test Duration prior to the zero and span calibration procedures (see *2.10.5 Acquiring the Test Duration*). If this has been completed at the time of set up, it is not necessary for subsequent zero or span tests.

Routine calibration consists of periodic zero and span calibration procedures. These procedures make fine adjustments to compensate for material build up, mechanical wear, and environmental effects on the conveyor.

A calibration log should be completed and maintained whenever a zero or span test is performed. (See *3.4.4 Keeping a Calibration Record*.)

NOTE

During zero and span calibration, the resolution of the displayed total is 10 times greater than it normally would be.

3.4.1 Zero Calibration

A zero calibration establishes the zero constant to be used by the Mini 11-101F for calibrating the scale. This calibration can be automatic or manual. *Auto Zero* uses a calculated zero constant and re-calculates it to automatically adjust the weight signal to provide a zero indication at empty belt conditions. *Manual Zero* requires you to enter the zero constant.

3.4.1.1 Auto Zero

Auto Zero allows automatic adjustment of zero to produce a zero accumulation when no material is passing over the belt scale. It is specifically intended for zeroing out the belt and its variations in weight over a period specified by the Test Duration.

Make sure the belt is empty and running at maximum speed. If the belt has not been run prior to Auto Zero calibration, it should be run for at least thirty (30) minutes.

Follow this procedure to have the system calculate the auto zero constant:

1. Press the **CAL**
2. Press **ENTER**, the Mini 11-101F begins calculating auto zero.

Accumulation continues and terminates automatically at the end of the test duration. The accumulated tons flash on the display. Record this number to determine the zero error.

Accumulation of tons received during auto zero does not increment actual material totals.

3. Press **ENTER**
ERR ± XXX.X% displays
Record this on the calibration record.
4. Press **ENTER**
ZERO XXXX displays, this is the new zero reference number.
Record this as the new zero number on the calibration record.
5. Press **ENTER**
ACQUIRED displays indicating the auto zero has been acquired.
6. Press **RUN/SET-UP** and the recomputed zero number is installed.

3.4.1.2 Manual Zero

Manual zero calibration allows you to make a direct change to the zero, providing you know the zero constant. Follow this procedure to manually enter the zero constant.

1. Press the **CAL**
2. Press **↓** until **ZERO** displays.
3. Press **ENTER** to display the current value
4. Press **ENTER**, the display flashes
5. Press the arrow keys to enter the zero constant.
6. Press **ENTER** to save your selection.
7. Press **RUN/SET-UP** to return to Run mode.

3.4.2 Span Calibration

A span calibration tests the accuracy of a scale when a known or simulated load is applied to the scale and results are compared to a known reference weight to calculate a span number. Span is the number automatically or manually adjusted to make the displayed weight equal to the reference weight or calibration constant.

Span calibrations on the Mini 11-101F can be automatic or manual. *Auto Span* allows automatic adjustment of span when calibrating to a known weight standard. *Manual Span* requires you to enter the span number.

Auto Span allows automatic span adjustment so that for a given simulated belt loading, the total accumulated weight over a specified test duration equals the calibration constant (Calcon). There are four ways to calculate span:

- Test Weights
- Calibration Chain
- Electronic Resistance (R-Cal)
- Material

3.4.2.1 Auto Span Calibration Using R-Cal Input

The R-Cal method shunts a resistor across the load cell's bridge circuit to simulate an actual applied weight.

This is the quicker, simpler method of automatic span calibration. Run the belt empty at maximum speed. If Auto Zero has not been performed, complete Section [3.4.1 Zero Calibration](#) before proceeding.

1. Press **CAL**
2. Press **↓**
SPAN CALIBRATION displays
3. Press **ENTER**
CALCON RCAL displays
4. Press **↓**
READY TO START displays
5. Press **ENTER** to begin the span calibration.
Accumulation continues and terminates automatically at the end of the established test duration.
6. The accumulated tons display and flash. Record this number on the calibration record.
7. Press **ENTER**
ERR ±XXX.X% displays. this is the "as found error" in percent of Calcon. Record this number in the calibration record.
8. Press **ENTER**
SPAN XXXX displays, this is the new span number. Record this number as new span.
9. Press **ENTER**
ACQUIRED displays, indicating the auto span has been acquired.
10. Press **RUN/SET-UP** to return the integrator to run mode.

NOTE

The Auto Zero and Auto Span calibrations should be performed before attempting a material calibration. Repeatability can be tested by completing several tests in a row with or without acquiring new values for each test.

3.4.2.2 Auto Span Calibration Using Test Weights or Chains

If you are calibrating with static weights or chains you must first set it up in *Selecting the Calibration Method* on page 2-21. If you have not completed the procedures, go back and do so now.

The test weights method uses certified test weights as a test load that is then used as the simulated weight for automatic span calibration.

The test chain method uses a roller chain that has a known weight per unit length (lbs/ft). The chain is placed on top of belt and secured at each end. The weight over the weigh span simulates belt loading.

When calibrating with static weights or chains, stop the belt and apply either standard and restart the belt.

Follow this procedure to calibrate with weights or chains.

1. Press **CAL**
2. Press **↓**
SPAN CALIBRATION displays
3. Press **ENTER**
CAL WGH OR CHAIN displays
4. Press **ENTER** and use the arrow keys to enter the calculated calibration constant for either standard.
5. Press **ENTER** to save the constant
6. Press **↓**
7. **READY TO START** displays
8. Press **ENTER**
Accumulation continues and terminates automatically at the end of the test duration.
9. The accumulated tons display and flash. Record this number.
10. Press **ENTER**
ERR ±XXX.X% displays
11. Press **ENTER**
SPAN XXXX displays
12. Press **ENTER**
ACQUIRED displays, indicating the span number has been acquired.

13. Stop the conveyor belt and remove any weights or chains.
14. Press **RUN/SET-UP** to return the integrator to run mode.

3.4.2.3 Auto Span Calibration Using Material

Material calibration is a machine-directed procedure for calibrating the Mini 11-101F Integrator using the material the scale will be weighing. The calibration is done by running a known quantity of material over the scale for a period of time.

The material used for this calibration must be pre weighed or post weighed to a known accuracy on a static scale to obtain the actual weight of the material (the reference weight).

The R-Cal or test weight Calcon should be factored following a material test span calibration. The factored Calcon can then be used for all routine auto span calibrations.

Follow this procedure to determine the span number using material.

1. Press **CAL**
2. Press **↓** twice
MATL CALIBRATION displays
3. Press **ENTER**
Sets the **CAL TOT** to zero and enables it to totalize the test load.
4. Run sufficient material across the scale at the normal feed rate, preferably between 50 and 100 percent of the rated capacity.
5. Press **ENTER** to stop the acquisition of the calibration total.
6. Press **ENTER**
The calibration total is stored, normal totalization resumes, and **ACQUIRED** displays.
7. Press **RUN/SET-UP**
The symbol '**M**' will be blinking on the left side of the rate display indicating a material calibration has been started but not completed.

Continue with the next procedure to complete material calibration.

Material Post Span Procedures

This procedure must be run after material calibration. It compares belt scale totalized weight with static weight of the same material to compute a new span value.

1. Press **CAL**
2. Press **↓** three times
POST SPAN displays

NOTE

Post Span does not display unless a Material Test is being run.

3. Press **ENTER**
REF WEIGHT displays
4. Press **ENTER**
XXXXXXXXXX displays previous totalized test load
5. Press **ENTER**
6. Press the arrow keys and enter the actual weight of the test load.
The weights must be expressed in the same units as you designated in [2.10.3.1 Scale Units](#) (tons, lbs, kg).
7. Press **ENTER** to save your selection.
8. Press **↓**.
The calculated span error displays: ERR ±XX.X%
9. Press **ENTER**
The recomputed span displays: SPAN XXXXXXXXX
10. Press **ENTER**
ADD TOTAL ? displays

NOTE

Pressing **RUN/SET-UP** at this point does not add the test load value to master total. A new span is acquired.

11. Press **ENTER**
ACQUIRED displays indicating the recomputed span has been installed. The test load is added to the master total.
12. Press **RUN/SET-UP** to return the integrator to Run mode.

3.4.2.4 Factoring R-Cal After Span Calibration With Weights or Material

This procedure is executed *only* if a span calibration using test weights or material has been done and R-Cal has not yet been factored.

The calculated R-Cal calibration constant cannot be factored or changed with automatic Calcon selected.

NOTE

The Mini 11-101F will not alter the span based on the results of this procedure. The system assumes the span is correct based on a test weight or material calibration. This procedure simply acquires the R-Cal factor, which can then be used to check and change the span between test weight or material calibrations.

Use the following procedures to begin factoring R-Cal.

1. Press **RUN/SET-UP**
2. Press the **↓** twice
CAL DATA displays
3. Press **ENTER**
CALIBRATION MODE displays
4. Press **ENTER**
ELECTRONIC RES (default) displays or WGH OR CHAIN displays
5. Press **ENTER**, and press **↓**
RCAL MODE displays
6. Press **ENTER** and select **MANUAL CALCON**
7. Press **ENTER**

NOTE

Be certain the belt is warmed, running empty, and the scale is properly zeroed. (Refer to [Section 3.4.1.1 Auto Zero](#) to perform an auto zero.)

NOTE

The calculated R-Cal cannot be factored or changed with **AUTOMATIC CALCON** selected.

8. Press **CAL** and press **↓**
SPAN CALIBRATION displays
9. Press **ENTER**
CALCON RCAL displays

10. Press **↓**
READY TO START displays
11. Press **ENTER**
±XXXXXXXXXX displays, and accumulation continues and terminates automatically at the end of the test duration.
12. The accumulated tons flash in the display
Record the displayed number for the new CALCON RCAL
13. Press **RUN/SET-UP** to return to Run mode.
14. Press **CAL** and **↓** until
SPAN CALIBRATION displays
15. Press **ENTER**
CALCON RCAL displays
16. Press **ENTER** and use the arrow keys to enter the new Calcon R-Cal.
Press **ENTER** to save your selection.
17. Press **RUN/SET-UP** to return the integrator to Run mode.

3.4.2.5 Factoring Test Weights/Chains Calcon After Span Calibration With Material

This procedure is executed *only* if a span calibration using test weights or material has been done and Calcon has not yet been factored.

NOTE

Be certain the belt is warmed, running empty, and the scale is properly zeroed. (Refer to [Section 3.4.1.1 Auto Zero](#) to perform an auto zero.)

1. Press **RUN/SET- UP**
2. Press the **↓** until
CAL DATA displays
3. Press **ENTER**, select WEIGHT OR CHAINS, press **ENTER** to save your selection.
4. Stop the belt conveyor, apply the weight standard, and restart the belt conveyor.
5. Press **CAL** and press **↓** until
SPAN CALIBRATION displays
6. Press **ENTER**
CAL WGH OR CHAIN displays
7. Press **↓**
READY TO START displays

8. Press **ENTER**
±XXXXXXXXXX displays, and accumulation continues and terminates automatically at the end of the test duration.
9. The accumulated tons flash in the display, record the displayed number for the new Calcon.
10. Press **CAL**
11. Press **↓**
SPAN CALIBRATION displays
12. Press **ENTER**
CAL WGH OR CHAIN displays
13. Press **ENTER**
The previous calcon displays
14. Press **ENTER** and press the arrow keys to enter the new Calcon.
15. Press **ENTER** to save your selection
16. Press **RUN/SET-UP** to return the integrator to Run mode.

3.4.2.6 Manual Span Calibration

Manual span calibration allows you to make a direct change to the span, providing you know the span constant.

NOTE

If you manually enter the span, consider factoring calcons for simulated load tests.

1. Press **CAL**
2. Press **↓** until SPAN displays
3. Press **ENTER**
The current span value displays
4. Press **ENTER** and the display flashes.
5. Press the arrow keys to enter the span constant
6. Press **ENTER** to save your selection.
7. Press **RUN/SET-UP** to return the Integrator to Run mode.

3.4.3 Routine Calibration

Routine calibration consists of periodic zero and span calibration procedures. These procedures make fine adjustments to compensate for material build up, mechanical wear, and various conveyor characteristics.

Run the belt empty during routine calibrations. Always perform zero calibration before span calibration.

Since most installations differ in characteristics, Ramsey recommends a record be kept of calibration results. This helps to determine the frequency of calibration checks necessary to maintain your accuracy requirements. (See 3.4.4 *Keeping a Calibration Record.*)

3.4.3.1 Routine Zero Calibration

To begin routine zero calibration (Refer to [Section 3.4.1.1 Auto Zero](#))

1. Press the **CAL**
ZERO CALIBRATION displays
2. Press **ENTER**
Calibration begins. After approximately six minutes X.XX displays.
3. Press **ENTER**
ERR:X.XX% displays
4. Press **ENTER**
ZERO XXXXXX displays
5. Press **ENTER**
ACQUIRED displays
6. Press **RUN/SET-UP** to return the integrator to Run mode.

3.4.3.2 Routine Span Calibration Using Electronic Calibration

To begin routine span calibration follow this procedure: (Refer to [Section 3.4.2.1 Auto Span Calibration Using R-Cal Input](#))

1. Press **CAL** and **↓**
SPAN CALIBRATION displays
2. Press **ENTER**
CAL CON RCAL displays
3. Press **↓**,
READY TO START displays
4. Press **ENTER**
Calibration begins. After approximately six minutes, XX.XX displays.

5. Press **ENTER**
ERR:X.XX% displays
6. Press **ENTER**
SPAN XXXXXX displays
7. Press **ENTER**
ACQUIRED displays

3.4.3.3 Routine Span Calibration Using Weight or Calibration Chains

To begin routine span calibration using weight or calibration chains, follow this procedure: (Refer to [Section 3.4.2.2 Auto Span Calibration Using Test Weights or Chains](#)).

1. Press **RUN/SETUP** and **↓** two times
CAL DATA displays
2. Press **ENTER**
CALIBRATION MODE displays
3. Press **ENTER** to select calibration method
ELECTRONIC RES or WGHT OR CHAINS displays

NOTE

If WGHT OR CHAINS displays, skip to step 5.

4. If ELECTRONIC RES displays, press **ENTER**
The display flashes, press **↓** to select WGHT OR CHAINS
Press **ENTER** to accept the setting
5. Press **RUN/SET-UP**
6. Press **CAL**
SPAN CALIBRATION displays
7. Press **ENTER**
CAL WGH OR CHAIN displays
8. Press **ENTER**
The calibration constant, Calcon, for the static weight or calibration chain is displayed. (Refer to [2.10.4.1 Selecting the Calibration Method](#) to determine the Calcon value.)
9. Press **↓**
READY TO START displays
Apply static weights or position calibration chain on the belt. Start the conveyor.

10. Press **ENTER**
Calibration begins. After approximately six minutes, XX.XX displays.
11. Press **ENTER**
ERR: X.XX% displays
12. Press **ENTER**
SPAN XXXXXX displays
Record this number as the left span in your calibration report.
13. Press **ENTER**
ACQUIRED displays
14. Stop the belt and remove weights or chain
15. Press **RUN/SET-UP** to return to Run mode.

3.4.4 Keeping a Calibration Record

To better maintain the accuracy of your scale, you should keep a record of calibration results. This will help you determine the frequency of routine calibration to meet your accuracy requirements. The following chart illustrates the information you should record.

Table 3-2. Zero Test Data Log

Zero Test Data Log				
Conveyor Number:				
Scale Capacity:				
Test Time (sec):				
Date	Acc Tons	% Error	New Zero #	Comments

Table 3-3. Span Test Data Log

Span Test Data Log					
Electronic Res:					
Cal Weight (lbs.):					
Chain (lbs/ft):					
Date	Calcon	Acc Tons	% Error	New Sapn #	Comments

3.5 Setting Up Protection Level

The Mini 11-101F allows you to define protection levels and associate passwords with them to guard against unauthorized changes to operating parameters. At the **TEST** menu you define a password. You have to activate the password at the **PROTECTION** menu.

3.5.1 Defining a Password

The following procedures demonstrate how to define and enter a password.

1. Press **RUN/SET-UP**,
PROTECTION displays
2. Press **↓** until test displays
3. Press **ENTER** until the screen flashes.
4. Use the arrow keys to enter a password. Record this password and store it in a safe place.

3.5.2 Activating a Password

The password is not active until you do the following:

1. Press **RUN/SET-UP**
PROTECTION displays
2. Press **ENTER**
NOT ACTIVE displays
3. Press **ENTER**,

You will be asked to enter the password you just selected in [3.5.1 Defining a Password](#).

4. Use the arrow keys to enter the password.
5. Press **ENTER** to save the password.
6. Select **ACTIVE** and press **ENTER** to save the selection.
7. Press **RUN/SET-UP** to return the integrator to Run mode.

Chapter 4

Maintaining and Troubleshooting the Mini 11-101F Integrator

This chapter provides information about maintaining the Mini 11-101F Integrator. It includes instructions for keeping the belt scale system clean and checking areas of the system that may cause operational problems.

There are also procedures for testing system components and identifying and fixing certain Mini 11-101F errors.

The maintenance information in this chapter should be sufficient to meet your service needs. If you encounter a problem that requires technical assistance, please call your service representative (refer to *Service and Repair Information* on page 5-1 for telephone numbers).

4.1 Overview

You can expect your Mini 11-101F Integrator to operate satisfactorily and hold its calibration for weeks with a minimum of maintenance. However, in a new installation, some calibration shifts may occur because of changes in measuring components or conveyor belt tracking. Check the system frequently at first to determine when calibration is required. Check the zero calibration every other day and the scale calibration every week for several months after installation.

Follow the recommendations in this chapter and in your scale documentation for checking calibration and maintaining the belt scale system. Your Mini 11-101F Integrator is capable of efficient and reliable operation when it is properly cleaned and maintained as recommended in this chapter.

4.2 Safety Precautions

 WARNING

Failure to follow safe installation and servicing procedures could result in death or serious injury.

- Make sure only qualified personnel perform installation and maintenance procedures in accordance with the instructions in this manual.
- Allow only qualified electricians to open and work in the electronics cabinets, power supply cabinets, control cabinets, or switch boxes.
- Covers over the electronics and rotating parts must always remain in place during normal operation. Remove only for maintenance, with the machine's power OFF. Replace all covers before resuming operation.
- During maintenance, a safety tag (not supplied by the factory) is to be displayed in the ON/OFF switch areas instructing others not to operate the unit (ANSI:B157.1).

 WARNING

High voltage that may be present on leads could cause electrical shock.

- Use extreme caution when testing in, on, or around the electronics, PC boards, or modules. There are voltages in excess of 115 V or 230 V in these areas.
- All switches (control, motor, power, as applicable) must be OFF when checking input AC electrical connections, removing or inserting printed circuit boards, or attaching voltmeters to the system.

 CAUTION

Keep hands and clothing away from all moving or rotating parts.

 CAUTION

Do not place or store objects of any kind on the machine.

4.3 Routine Maintenance

The Mini 11-101F Integrator is a solid-state device and, as such, should require very little maintenance. This section offers suggestions for maintaining accurate operation of both the belt scale and the Mini 11-101F.

4.3.1 Cleaning Instructions

Keeping your system clean is the single most important factor in ensuring that it stays in good operating condition. The belt scale should be cleaned regularly to maintain the efficient operation of the system. Keep the scale clear of rocks, dust, and material build up. Material build up in certain areas of the equipment can affect weighing performance.

Be sure to follow the cleaning and routine maintenance instructions for your belt scale in addition to those presented in this section.

The Mini 11-101F front panel and enclosure can be wiped clean with a damp cloth and, if necessary, a mild detergent.

- All panels and doors covering the electronics must be in place and tight. Damage to the electronics could result from water, moisture, or contamination in the enclosure.
- Do *not* use abrasive cleaners, especially on the display window.
- Do *not* use any kind of scraper to remove debris from the front panel.
- Do *not* use solvents to clean the system because of the possibility of damage to electrical leads and plastic components.

4.3.2 Preventive Maintenance

There are a number of tasks you can perform to prevent problems that may affect belt scale performance and integrator accuracy.

- Keep the conveyor belt trained to run true to the center line of the idlers in the area of the scale when the belt is running empty as well as under loaded conditions.
- Adjust belt loading to stay within instrument range.
- Keep the material profile as uniform as possible.
- Material may form a film on the belt that is never discharged, especially when handling wet, fine materials. Use a belt scraper to remove film.

If you cannot remove the film, the zero calibration will need to be adjusted. Any change in the buildup of film adhering to the belt will require further zero adjustment.

- Keep the Mini 11-101F enclosure door tightly closed to prevent dirt infiltration.

4.3.3 Calibration Checks

The system should be checked frequently to determine when calibration is required. It is recommended that zero calibration be checked every other day and that scale calibration be checked every week for several months after installation. Observe the results and lengthen the period between calibration checks if your scale is holding its calibration well.

If the system does not operate correctly after initial set up and calibration, first try performing the procedures again (See [Cold Start Procedure on page 3-10](#)). If the problem persists, follow the suggestions in this section.

4.3.3.1 Zero Calibration Shifts

When zero shift occurs, the span shifts by a like number of tons/hour. This then appears as a span shift. Common causes of zero shifts include:

- Material buildup on the scale or belt
- Idler alignment
- Conveyor belt tracking
- Non-uniform conveyor belt
- Conveyor belt stretch
- Problems with the load cell or the electronic measuring components
- Improper shielding or grounding of field wiring

4.3.3.2 Span Calibration Shifts

Span shifts do not affect zero. Common causes of span shifts include:

- Speed sensor roll buildup or slipping
- Idler alignment or spacing
- Changes in material density or profile
- Conveyor belt tracking
- Problems with the load cell or the electronic measuring components
- Improper shielding or grounding of field wiring

4.4 Troubleshooting and Maintenance Procedures

⚠ CAUTION

This instrument should not be operated at more than the production rate stated on your Equipment Specification sheet or used in applications other than those stated in the original order.

⚠ CAUTION

Before performing any drastic modifications to this instrument, refer to your warranty or contact your service representative.

If your Mini 11-101F is not operating correctly, there are several things you can do to determine the cause of the problem.

First, do a visual inspection—not only of the Mini 11-101F but also of the conveyor belt and the material load. If you find a problem that you cannot correct, contact your service representative.

If the problem is not apparent, a qualified service technician may be required to do troubleshooting procedures or replace parts.

4.4.1 Visual Inspection

If you are experiencing operational problems with the Mini 11-101F Integrator, a quick visual inspection may reveal the source of the problem. Check the following items before proceeding to more specific troubleshooting procedures.

1. Check power
 - Make sure power is ON at the mains.
 - Make sure there is incoming power to the Mini 11-101F.
 - Make sure the input power selection switches are set to the correct voltage. (See *“Input Power Requirements” on page 2-2*.)
 - Make sure the fuse is firmly seated.
2. Check connections
 - Make sure all field wiring terminations are secure.
 - Make sure the display module and keyboard connectors are firmly seated in their connections.
 - Make sure the remote counter and input/output modules are secure in their sockets.
 - Make sure all jumpers are in the correct position.

3. Check the front panel.
 - Check system status LEDs.
 - Check and handle alarm messages.

4.5 Alarm Messages

The Mini 11-101F Integrator has built-in troubleshooting capabilities in the form of system alarms. A number of possible problems are automatically detected and a message is displayed on the **RUN MENU**. The **ALARM LED** on the front panel also flashes when an alarm condition is detected.

The errors detected by the Mini 11-101F are as follows:

- **LOW RATE** - low material flow rate.
- **HIGH RATE** - high material flow rate.
- **REM CNT OVRFL** - remote counter overflow
- **BLT PLS CNT OVF** - belt pulse counter overflow
- **COLD START** - installs default set-up and calibration constants.
- **LOAD CELL FAIL** - loss of the load cell signal.
- **MAX ZERO CORRECTION** - zero correction exceeds the range setting.
- **MATH ERROR** - incorrect set-up data is entered or hardware failure.

Alarms can be defined as two types in the Mini 11-101F, *process alarms* and *hardware alarms*.

4.5.1 Process Alarms

A process alarm activates when the process variable exceeds the alarm set point.

The low rate and high rate alarms are *Process Alarms*. A set point is programmable for each. Output relays can be assigned for each. (See [A.2.5 Alarm Definition Menu](#))

If the alarm condition has been cleared, the status of the relay returns to normal. Press **ENTER** to reset the lighted LED and message display.

To reset all of the alarms, press **ENTER** until the **NO ALARMS** message is displayed.

4.5.2 Hardware Alarms/ Self Test Procedure

Hardware alarms can detect failures in the integrator, load cell, speed input, and numerical data. There are no programmable set points. When a hardware alarm signals there are a variety of service diagnostic tests you can perform. These tests should be used as part of the troubleshooting procedures. The self tests are found within the **TEST MENU**.

4.5.2.1 Displaying Raw A/D Data (A/D Gross)

The A/D GROSS display shows the analog/digital converter gross which is the total weight on the load cells. To access this display do the following:

1. Press **RUN/SET-UP** and press the **↓** until TEST displays.
2. Press **ENTER** and press the **↓** until AD/ GROSS displays.
3. Press **↓** to continue to the next menu item or **RUN/SET-UP** to put the integrator in Run mode.

4.5.2.2 Displaying Raw A/D Data (A/D Net)

A/D NET is the analog/digital converter gross after the zero constant has been subtracted. It indicates the weight on the load cell.

Press **↓**, move to A/D NET and press **ENTER**.

4.5.2.3 Displaying Pulse per Minute (PLS/Min)

The pulse per minute displays the pulse per minute of the designated speed sensor. The values were set up in the I/O (Input/Output) menu at the SPEED INPUT selection.

Press **↓**, move to PLS/MIN and press **ENTER**.

4.5.2.4 Displaying Belt Speed (SP)

This menu item displays the current speed of the belt and is displayed in distance/time.

Press **↓**, move to SP and press **ENTER**.

4.5.2.5 Displaying Belt Loading (PS)

Belt loading displays the wt/distance of the load on the load cell.

Press **↓**, move to PS and press **ENTER**.

4.5.2.6 Displaying Load Cell Output (LC SUP)

This menu item displays the mV output of the load cell with a load. The load cell output will change depending on the load.

Press **↓**, move to LC SUP and press **ENTER**.

4.5.2.7 Displaying Correction Zero (C_Zero)

Correction Zero is used to trim the minimum value of the analog output. The value can be changed at this menu. Values manually entered are adjusted back to zero when a scale auto zero test is performed.

1. Move to C_ZERO and press **ENTER**, the current value displays.
2. Press the arrow keys to enter a changed value.
3. Press **ENTER** to save the changes.
4. Press **↓**, move to the next menu item.

4.5.2.8 Displaying Correction Span (C_Span)

Correction span sets the parameters or acceptable range for the analog output.

1. Move to C_SPAN and press **ENTER**, the current value displays.
2. Press the arrow keys to enter a changed value.
3. Press **ENTER** to save the changes.
4. Press **↓**, move to the next menu item.

4.5.2.9 Displaying the Software Version (Softwar Ver)

The current software version in the Mini 11-101F is displayed for reference only on the TEST scroll.

Press **↓**, move to SOFTWARE VER and press **ENTER**.

4.5.2.10 Testing Memory

A self diagnostics test that test the Random Access Memory (RAM) of the Mini 11-101F Integrator.

Press **↓**, move to MEMORY TEST and press **ENTER**,

- RAM OK displays if there are no memory problems.
- FAIL displays if there is a problem with the mother board.

4.5.2.11 Testing Input

This diagnostic procedure tests the digital inputs and indicates if the inputs you entered in the I/O MENU are open or closed (on or off). (See [A.2.4 Input/Output \(I/O Data\) Menu](#).)

1. Move to **INPUT TEST** and press **ENTER**. The display shows all three inputs at one time. **Example:** INPUTS 010

The first digit on the right of the display refers to input 3, the second digit from the right refers to input 2 and so on.

If an input displays 0, it indicates the input is open (off). If it displays a 1, it indicates the input is closed (on).

2. Press **↓**, move to the next menu item.

4.5.2.12 Testing Output

This diagnostic procedure tests the digital outputs and indicates if the outputs you entered in the I/O MENU are open or closed (on or off). (See [A.2.4 Input/Output \(I/O Data\) Menu](#).)

1. Move to **OUTPUT TEST** and press **ENTER**. The display shows all five outputs at one time.

Example: OUTPUTS 10010

The first digit on the right of the display refers to input 5, the second digit from the right refers to input 4, and so on.

If an input displays 0, it indicates the input is open (off). If it displays a 1, it indicates the input is closed (on).

2. Press **↓**, move to the next menu item.

4.5.2.13 Lamp Test

LAMP TEST tests the lamp in the LED display area.

Press **↓**, move to **LAMP TEST** and press **ENTER**. All LEDs and digits of the display should blink for a number of seconds.

4.5.2.14 Entering a Forced Value

FORCE VALUE allows you to enter a forced value of wt/time for testing or calibrating remote equipment.

1. Press **↓**, move to **FORCE VALUE** and press **ENTER**.
2. Press the arrow keys to enter the desired value, press **ENTER** to save your entry.

4.5.3 Load Cell Excitation and Signal Voltage

Follow the procedure below to test for load cell failure.

1. Measure excitation voltage across terminal 21 negative and 20 positive in the scale junction box.

This should be 10 VDC \pm 5%.

2. If the excitation voltage is incorrect, measure the excitation voltage in the Mini 11-101F Integrator across terminal M3-17 negative and M3-12 positive.

This should be 10 VDC \pm 5%.

3. Measure the DC mV signal voltage across terminal 22 positive and 23 negative in the scale junction box. This should be within 0-20 mV DC (2 mV/V load cell), 0-30 mV DC (3 mV/V load cell), or 0-18 mV DC (1.8mV/V load cell).

4. Measure DC mV signal voltage across terminal M3-14 positive and M2-15 negative in the Mini 11-101F Integrator.

This should be the same as the previous Step 3.

The mV output is in direct relation to weight applied. As weight is increased, output should increase.

4.5.4 Cold Start Procedure

It may be necessary to cold start the Mini 11-101F if the software becomes corrupted or if there has been an extended loss of power. Field entry data *will* be replaced with factory default constants.

Follow this procedure to force a cold start. Make sure you record all configuration, setup, and calibration data before beginning this procedure so you can re-enter it.

1. Turn power off at the main box.
2. Open the front panel.
3. Locate jumper SW4 in the upper center section of the mother board (*Figure 2-4*).
4. Remove the jumper SW4 and turn the power on. The memory is now erased.
5. Wait until the cold start message appears in the LED display.
6. Replace the jumper.

The following is a list of factory default settings that are installed on the Mini 11-101F after performing a cold start.

Table 4-1. Scale Data Menu
Default Settings

Menu Item	Default Setting
Scale Data Menu	
Scale Units	Tons
Decimal Place	1
Scale Capacity	200.0
Lcell Cap	250.0
Cells Number	1
Filter Damping	2 seconds
Low Rate	105%
High Rate	105%
Rate Alarm Delay	5 seconds
AZT Range	Disabled
Limit AZT	2.0%
Dead Band	0.0%

Table 4-2. Calibration Menu
Default Settings

Menu Item	Default Setting
Calibration Menu	
Calibration Mode	Electronic Res (R-Cal)
R-Cal Mode	Automatic Calcon
Cell MV/V	1.800 mV/V
Cell Resistance	350.000 ohms
Calibration Resistance	350.000 ohms
Lever Ratio	1.000
Idler Spacing	3.00 ft.
Idlers Number	1
Conveyor Angle	0.0 degrees
Calcon R-Cal	0

Table 4-3. I/O Data Menu Default Settings

Menu Item	Default Setting
I/O Data Menu	
Range MA	4-20 MA
Damping	2 sec.
Divide Out	100
Pulse Width	0.100 S
Input 1	Pulse
Language	English
Input 2	Clear Total
Input 3	Clear Total
Input 4	Not Used
Output 1	Instrument Ready
Output 2	Alarm
Output 3	Totalizer
Output 4	High Rate
Output 5	Not Used
Alt Rate-Tot	0 sec.
Data Format	MM-DD-YY

Table 4-4. Alarm Menu Default Settings

Menu Item	Default Setting
Alarm Menu	
Low Rate	Not Used
High Rate	Not Used
REM CNT OVRFL	Alarm
BELT PLS CNT	Alarm
Cold Start	Alarm
Load Cell Fail	Not Used
Max Zero Correction	Alarm
Math Error	Alarm

Table 4-5. Printer Scroll Menu
Default Settings

Menu Item	Default Setting
Printer Menu	
Baud Rate	9600
Stop Bits	1
Parity	Even
Word Length	8
Handshake	Not Used
End of Line	CR+LF
Print Interval	0
Report Format	DATE 09-19-00 TIME 02:40:35 RATE 133.5TPH MASTER TOTAL 239961.2 Ton RESET TOTAL 0
String #1	No
Contents String #1	XXXXXXXXXXXXXXXXXX
String #1 Position	01 01
String #2	NO
Contents String #2	XXXXXXXXXXXXXXXXXX
String #2 Position	01 02
String #3	NO
Contents String #3	XXXXXXXXXXXXXXXXXX
String #3 Position	01 03
Rate Position	01 04
Mtotal Pos	01 05
Rtotal Pos	01 06
Date Position	01 07
Time Position	01 08

4.5.5 Removing a Forgotten Password

If you have forgotten the password entered into the integrator, follow this procedure to remove the password.

1. Press **RUN/SET-UP**
PROTECTION displays
2. Press **ENTER** three times.
The left most zero begins flashing.
3. Use the arrow keys to enter the default password, **20000000**.
4. Press **ENTER** to save the selection.

This sets the password to **NON ACTIVE**. (Refer to [Setting Up Protection Level on page 3-16](#) for setting a new password).

4.5.6 Resetting the Master Total

The master total would be reset to zero if the Mini 11-101F Integrator were used on a portable application where the conveyor is moved. Each new location would require the master total to be reset.

Follow this procedure to reset the master total.

1. Press **RUN/SET-UP**
PROTECTION displays
2. Press **ENTER** three times
The left most zero begins flashing
3. Use the arrow keys to enter the number **07832500**, press **ENTER**.
4. Press **RUN/SET-UP**
5. Press **RATE/TOTAL**
MT (master total) displays.
6. Press **ENTER**
CLEAR TOTAL displays
7. Press **ENTER** to reset the master total to zero.

You must clear the Ramsey protection level after resetting the master total. Use the following procedure to clear the protection level.

1. Press **RUN/SET-UP** and PROTECTION displays
2. Press **ENTER** three times
The left most zero begins flashing.
3. Enter the previously installed password or, if there has been no password previously installed, enter in the default password **20000000**.
4. Press **ENTER**, setting the password to **NON ACTIVE**.
5. Press **RUN/SET-UP** to return the integrator to Run mode.

4.5.7 Replacing the Lithium Battery

⚠ WARNING
Danger of explosion if battery is incorrectly replaced.

If you have selected the printer option for the Mini 11-101F, the COMM board is powered by a lithium battery. The battery can be removed and replaced without any special tools. Replace the battery only with the same or equivalent type recommended by Thermo Ramsey. Dispose of the used battery according to manufacturer’s instructions on the battery and your local Hazardous Waste Policy.

You may also return the used battery to Ramsey, freight prepaid, for disposal. Contact our Repair and Returns department to get a Return Material Authorization number before shipping any product for disposal (refer to [5.1 Service and Repair Information](#)).

4.6 Jumper and Switch Configuration on Circuit Boards

The following table lists all jumpers and switches located on the Mini Integrator circuit boards. Jumpers and switches normally need not be changed. They are listed here in the event one is mistakenly moved.

The word *Open* in the table indicates there is no jumper, the word *Close* means a jumper is in place. The shaded boxes indicate the default setting of the jumpers.

Table 4-6. At A Glance Mother Board Jumper/Switch Configuration

Mother Board			
Function	Pot/Jumper	Status	Description
Coarse Zero	P2		Coarse zero trimmer
	J1	OPEN	Default - disable coarse zero trimmer
		CLOSE	Enable coarse zero trimmer
IC4 Converter	J2	OPEN	Default - Factory configured, do not change
Load Cell Sensing	S1, S2	OPEN	External sensing
		CLOSE	Default - Internal Sensing
Reset Circuit	J6	CLOSE	Default - Factory configured, do not change
	J7	OPEN	Default - Factory configured, do not change

Mother Board			
Function	Pot/Jumper	Status	Description
Model Selection	J10A	CLOSE	Mini 11-100 F/P
	J10B	OPEN	
	J10A	OPEN	Mini 11-101 F/P
	J10B	CLOSE	
Debug Serial Port	J11A	CLOSE	38,400 Baud
	J11B	OPEN	
	J11A	OPEN	Default - 19,200 Baud
	J11B	CLOSE	
	S4	CLOSE	
Serial Port	SW5	OPEN	Disable CTS (Factory configured, do not change.)
Line Power Reset	S3	CLOSE	Factory configured, do not change
Display Contrast	P1		Display contrast control
Display Light	P4		Display light control
Speed Input	J12A	CLOSE	Default - direct speed input
	J12B	OPEN	
	J12A	OPEN	Inverted speed input
	J12B	CLOSE	
Filter Cut Out Frequency	J13A	OPEN	Frequency greater than 30 Hz
	J13B	CLOSE	
	J13A	CLOSE	Default - Frequency less than 29 Hz
	J13B	OPEN	
Line Frequency	SW1	OPEN	Default - 60 Hz
		CLOSE	50 Hz
Force Cold Start	SW4	CLOSE	Default - retain data at power up
		OPEN	Force Cold Start at power up
Display Selection	S8	OPEN	Select display AMEL mod. 013231160803135
		CLOSE	Select old type display

Mother Board			
Function	Pot/Jumper	Status	Description
Digital Output KF (Out 4)	J8	OPEN	Output is software controlled
	J9	CLOSE	
	J8	CLOSE	Output is hardware controlled (watch dog function)
	J9	OPEN	
Converter IC37	J14	OPEN	Factory configured, do not change
	J15	OPEN	Factory configured, do not change
Analog Output	J16 A	OPEN	0-10 VDC
	J16 B	CLOSE	
	J16 A	CLOSE	0-20 mA or 4-20 mA
	J16 B	OPEN	
P3			Analog Output Span Adjust
P5			Analog Output Zero Adjust

Table 4-7. At A Glance Optional COMM Board Jumper/Switch Configuration

Optional Com Board			
Function	Pot/Jumper	Status	Description
Battery	J12	OPEN	Battery not inserted
		CLOSE	Battery inserted
Serial Port	J4 A	OPEN	Factory configured, do not change
	J5 A	CLOSE	Factory configured, do not change
	J5 B	OPEN	Factory configured, do not change
	J4 B	CLOSE	Factory configured, do not change
	J2-J11 A	CLOSE	RS422
	J2-J11 B	OPEN	
	J2-J11 A	OPEN	RS232
	J2-J11 B	CLOSE	

Chapter 5

Service, Repair, and Replacement Parts

This chapter provides information about service, repair, and replacement parts for your Mini 11-101F Integrator. It includes the telephone numbers for various departments at Thermo Ramsey. The procedure for ordering replacement parts, a *Return Material Authorization* form, and the parts list for the Mini 11-101F Field Mount Integrator are included in this chapter.

5.1 Service and Repair Information

The maintenance information in this manual is designed to meet your service needs. If you should encounter a problem that requires technical assistance, you may call Ramsey Product Service at (763) 783-2603.

Ramsey also provides on-site service technicians to assist customers with installation, set up, initial calibration, customer training, maintenance, and repair. Contact the Ramsey Field Service department at the number given below for current rates and scheduling.

Ramsey has a repair center located at our plant in Minneapolis, Minnesota. Products that need system checkout or repair can be returned to the plant with the *Return Material Authorization* (RMA) form found on page 5-3. Contact our Repair and Returns department at (763) 783-2774 to get an RMA number to use on the form.

NOTE

Have your machine model number and serial number available when you call.

Main Switchboard	(763) 783-2500
FAX	(763) 783-2525
Technical Assistance	(763) 783-2603
Field Service	(763) 783-2660
Return Material Authorization & Repair	(763) 783-2774

5.2 Parts Ordering Information

For the fastest service when ordering parts, telephone or FAX the Ramsey Parts Department at the numbers given below. Your regional field service representative can also assist you with parts orders, but this may delay shipment of your parts.

The recommended procedure for ordering parts is:

1. Determine the broken or faulty part.
2. Locate the part in the Parts List on page 5-4.
3. Find the part number(s) for the item(s) you need.
4. Before you contact Ramsey for your parts, make sure you have the following information:
 - Machine model and serial number
 - Purchase Order number
 - Date required
 - Preferred shipping method
 - Part number(s), description, and quantity needed
5. Telephone or FAX:

Thermo Ramsey
Customer Service Department
501 90th Ave. NW
Minneapolis, MN 55433

FAX: (763) 780-2525

Customers A through I - (763) 783-2775

Customers J through Z - (763) 783-2773

Return Material Authorization and Repair - (763) 783-2774

Business hours are 8:00 a.m. to 4:30 p.m. Central Time.

5.3 Return Material Authorization



RMA No. R- _____

(This RMA number must be marked on all paperwork and on the outside of the package.)

Req'd By: _____

Return, Freight Prepaid to:

Date: _____

Thermo Ramsey
501 90th Avenue N.W.
Minneapolis, MN 55433
Telephone: 763-783-2774
Fax: 763-783-2525

Customer Contact: _____

Phone No.: () _____
Area Code

Bill to Customer #: _____

Ship to #: _____

Returned From: _____

Return To: _____

Description of Material Being Returned: _____

Describe Equipment Malfunction or Defect. If any: symptoms: _____

Minimum Charge:

Informed Customer of _____ Inspection Charge Per Item

Service Requested:

P. O. No.: _____

Repair & Return Estimate Required

Original P. O. or RTI Order No.: _____

Return for Credit

Warranty Repair or Replacement

Serial No.: _____

Original P. O. No.: _____

Original Order/Job No.: _____

Return Warranty/Exchange Unit

Shipped on RTI Order No.: _____

Other: _____

Disposition/Comments: (For RTI internal use only)

5.4 Parts List

This list provides part numbers and descriptions of the replaceable parts for the Mini 11-101F Field Mount Integrator.

ITEM DESCRIPTION	PART NO.
PCBA, Mother Board	051308
PCBA, A/C (Relay) Output Board	051310
PCBA, Serial Printer Interface Board	051034
A/C Assembly with Transformer and Relay Output Board	051332
A/C Transformer	051309
Keyboard Assembly	051311
Display Assembly	051312
Fuse, 110 VAC, 1.0 Amp, 5 × 20 mm	048438
Fuse, 220 VAC, 0.5 Amp, 5 × 20 mm	047272
Door Key	057425
Shock Mounts	057426

5.4.1 Disposal of Hazardous Waste

Disposal of lithium batteries and soldered printed circuit boards must be in accordance with your local Hazardous Waste Policy.

As an alternative you may return product supplied by Ramsey, freight pre-paid, for disposal. Contact our repair department for a Return Material Authorization Number before shipping any product for disposal.

Appendix A

Appendix A

Mini 11-101F Menus

This appendix describes all of the menu displays, menu scrolls, and minimum/maximum/default values for the Mini 11-101F Integrator.

The Mini 11-101F is a menu-driven machine that allows you to access all setup, test, and calibration parameters. You select and display menu scrolls by pressing the function keys on the front panel, then using the up and down **SCROLL** keys on the front panel. Optional menu scrolls and selections are available only if the option has been installed.

Scroll keys are used to select choices and enter data on the menu scrolls. If you enter a value for a parameter that is outside of the valid range, the system displays a warning message so you can re-enter the data.

To accept the default value displayed on any menu, press the down **SCROLL** key to scroll to the next screen.

If the integrator is password protected, you must enter the appropriate password before you will be allowed to make changes or perform routine calibrations. Menus may be viewed without entering the password, but no entries are allowed.

If you make an error while entering data and need to start over press the **RUN/SET-UP** key. Also press the **RUN/SET-UP** key to put the Mini 11-101F in Run mode.

The Mini 11-101F Integrator menus are shown on the following pages.

A.1 Run Menu

This section describes the Mini 11-101F Run Menu and the information that can be displayed on it. It also provides procedures for operations initiated from the Run Menu

The **RUN/SET-UP** menu is the normal mode of operation. At any time, pressing **RUN/SET-UP** returns the integrator to the Run mode, even if some other function is in progress.

The selectable displayed information in the **RUN** menu is:

- **PROTECTION** - Protection allows you to set the password function to **ACTIVE** or **NOT ACTIVE**. It can be accessed while the integrator is in Run mode by pressing the **RUN/SET-UP** key once.

- **FLOW RATE** - The rate at which bulk material is being conveyed and delivered. This information displays while the integrator is in Run mode.
- **MASTER TOTAL** - The aggregate of tons totalized by the integrator since installation. This number cannot be cleared. It can be accessed by pressing the **RATE TOTAL** key while the integrator is in Run mode.
- **RESET TOTAL** - Displays a totalized quantity. It can be accessed by pressing the **RATE TOTAL** key two times while the integrator is in Run mode.

If **ENTER** is pressed while the **RESET TOTAL** is on display, the next display states **CLEAR TOTAL?**. Pressing **ENTER** again clears the Reset Total.

- **PRINT TOTAL** - If the optional COMM board is installed a report is printed on demand. It can be accessed by pressing the **RATE TOTAL** key three times while the integrator is in Run mode and pressing **ENTER**.

The format on the report depends on set up. The default format is as follows:

DATE	09-19-00
TIME	02:40:35
RATE	133.5 TPH
MASTER TOTAL	239961.2 Ton
RESET TOTAL	0

An optional customer defined report is available. It includes the above data plus three alphanumeric strings printed in a position the user can define by entering row and column numbers for each item to be printed (See [A.2.6 Printer Scroll \(Optional\) Menu](#)).

- **ALARMS** - Scrolling to this menu item tells you the alarms that are currently exist. When you select **ALARMS** and press **ENTER**, if **NO ALARMS** displays this indicates there are no active alarms.

If one or more alarms exist, an alarm message is displayed for each. The following table shows how you can obtain the desired display

A.2 Set-up Menu

Set-up menus can also be accessed by pressing the **RUN/SET-UP** key. After pressing **RUN/SET-UP**, press **↓** on the front panel to access the menu items.

Table A-1. Set-Up Menu Displays

Key Pressed	Display
RUN/SET-UP	PROTECTION
DOWN ARROW	SCALE DATA
DOWN ARROW	CAL DATA
DOWN ARROW	I/O DATA
DOWN ARROW	ALARMS
DOWN ARROW	TEST

A.2.1 Protection Menu

The Protection Menu allows you to activate a password that has been entered at the Test Menu. (See *Setting Up Passwords* on page A - 20) Follow this procedure to activate your password.

The following procedures demonstrate how to define and enter a password.

1. Press **RUN/SET-UP**,
PROTECTION displays
2. Press **↓**
TEST displays
3. Press **ENTER** until the screen flashes.
4. Use the arrow keys to enter a password. Record this password and store it in a safe place.

A.2.2 Scale Data Menu

The Scale Data Menu provides access to the screens you use for set-up and calibration. In addition there are other menu items that can be added to the integrator to enhance usability.

The following three steps are common to the scale data set-up sequence. If you choose to use any default settings and there are no changes to be made to a specific menu item, press **↓** to scroll past the menu item.

1. Press **RUN/SET-UP**
SCALE DATA displays
2. Press **ENTER**
SCALE UNITS displays
3. Press **↓** to go to the next menu item

A.2.2.1 Setting the Scale Units

When you select a **SCALE UNIT**, you also select the units used for the rate display. Default scale units are Tons. All units are measured at a rate of units/hour. Scroll to **SCALE UNITS** and select the appropriate data.

Available selections for **SCALE UNITS** and the way they are displayed are listed below. Select the units you are using for your particular scale.

Units	Display	Weight	Length	Rate
Pounds	Lb	Lb	ft	Lb/h
Tons	TON	Lb	ft	TPH
Long Tons	LTN	Lb	ft	LTph
tons	t	kg	m	t/h
kg	kg	kg	m	kg/h

NOTE

If the LED display continues to flash, press **ENTER** until the flashing stops. Selections are *not* saved until the LED stops flashing.

A.2.2.2 Decimal Place

The DECIMAL PLACE menu lets you choose the number of decimal places to be displayed. Select the number of decimals.

Min: 0
Max: 3 (.000)
Default: 1 (.0)

NOTE

During zero and span calibration, the resolution of the displayed total is 10 times greater than it normally would be.

A.2.2.3 Scale Capacity

The SCALE CAPACITY menu allows changes in scale capacity. Enter the capacity of your scale.

Min: 1.0
Max: 100,000.0
Default: 200.0

A.2.2.4 Setting the Load Cell Capacity (LCELL CAP)

Enter the load cell capacity on the LCELL CAP menu. Enter the capacity of *only* one load cell. All load cells will be the same size.

The capacity of one load cell is 100kg = 220.5 and 220kg = 441.

Min; 10.00
Max; 15000.00
Default: 250.00

NOTE

If the unit measure of the load cell is tons (Tons) or pounds (Lb), then the display cell size is pounds (Lb). If the unit of measure is tons (t/metric ton) or kilograms (kg) the display cell size is kilograms (kg). (Convert as necessary 1 kg = 2.2 lb)

A.2.2.5 Setting the Number of Load Cells (Cells Number)

The CELLS NUMBER menu allows you to enter the total number of load cells being used.

Min: 1
Max: 4
Default: 1

A.2.2.6 Setting the Filter Damping

When process variables are displayed on the screen, they can be damped by a programmable factor to filter out variations that can be introduced by mechanical vibrations.

The FILTER DAMPING menu allows changing the rate filter damping of the display. It does not dampen the rate output.

Min: 0 Sec
Max: 30 Sec
Default: 2 Sec

A.2.2.7 Setting the Low Rate Set

The LOW RATE menu function sets the minimum rate value and when it is reached will trigger an alarm.

Min: 0%
Max: 100%
Default: 0%

A.2.2.8 Setting the High Rate Set

The HIGH RATE menu function sets the maximum rate value and when it is reached will trigger an alarm on the Mini 11-101F.

Min: 0%
Max: 150%
Default: 150%

A.2.2.9 Setting the Rate Alarm Delay

The RATE ALARM DELAY menu allows you to enter the number of seconds before the alarm sounds when the alarm is triggered.

Min: 0 sec.
Max: 60 sec.
Default: 5 sec.

A.2.2.10 Setting the Auto Zero Track Range (AZT Range)

AUTO ZERO TRACKING, when enabled, allows continuous unassisted auto zeroing if the flow rate is less than an amount in percent of scale capacity (AZT Range in scale data). The flow rate must remain below AZT range for at least 2 test durations for a successful Auto Zero Track cycle to be completed.

Auto Zero Tracking is enabled by entering a value other than zero. When enabled, a 'Z' will appear in the left hand side of the flow rate display. When the 'Z' is steady it indicates that the actual AZT cycle has started. The 'Z' continues flashing until the cycle is complete and zero is automatically changed if necessary. This procedure repeats itself as long as the belt is running and the flow rate remains below AZT range.

Min: 0%
Max: 20.0%
Default: 0% (disabled)

A.2.2.11 Setting the Auto Zero Tracking Limit (Limit AZT)

The LIMIT AZT menu defines the maximum amount of zero error (with reference to the scale capacity) that AZT can automatically compensate.

Min: 0.0%
Max: 20.0%
Default: 2.0%

A.2.2.12 Setting the Dead Band

The DEAD BAND is a percentage of the scale capacity (rate) in which the rate is ignored and a zero rate is forced. Totalization is frozen when the rate is below the dead band setting.

Min: 0.0%
Max: 5.0%
Default: 0.0% Calibration Data Menu

A.2.3 Calibration Menu

Calibration data defines the parameters to be used for calibrating the Mini 11-101F Integrator. Access these scrolls by pressing the **CAL** key on the front panel when the integrator is in Run mode.

A.2.3.1 Calibration Mode

The CALIBRATION MODE menu item allow you to select the method you are using to calibrate your scale.

Selections: Electronic Res (R-Cal), Weights or Chains
Default: Electronic Res (R-Cal)

A.2.3.2 R-CAL Mode

The Mini 11-101F Integrator automatically calculates and installs the Electronic Res (R-Cal) calibration constant if automatic calcon is selected.

The R-CAL MODE must be entered and the belt test length entered in the CAL scroll to enable automatic calculations of the R-Cal calibration constant.

Selections: Manual Calcon, Automatic Calcon
Default: Automatic Calcon

A.2.3.3 Cell mV/V - Load Cell Sensitivity

From the CELL MV/V menu item, enter the load cell sensitivity in. The standard sensitivity of cells used in Ramsey scale systems is:

- 10-101R Scale = 2.0 mV/v
- 10-30 Scale = 1.8 mV/v
- 10-20 Scale = 3.0 mV/v

Min: 1.000 mV/V
Max: 3.500 mV/V
Default: 1.800 mV/V

A.2.3.4 Cell Resistance

The CELL RESISTANCE menu item allows you to enter the resistance of the load cell(s). The resistance for the load cell has been recorded on the System Data Sheet in the front of your belt scale manual. It is also stamped on the load cell cable.

Min: 50.000 ohms
Max: 1000.000 ohms
Default: 350.000 ohms

A.2.3.5 Calibration Resistance

The CALIBRATION RESISTANCE menu item allows you to enter the resistance of the resistor installed in your Mini 11-101F Integrator. (See the system data sheet for exact resistance.)

Min: 50,000 ohms
 Max: 1,000,000 ohms
 Default: 165,000 ohms

A.2.3.6 Lever Ratio

The LEVER RATIO is the ratio between the weigh idler and the load cell. See the scale manual for exact dimensions:

Weighbridge	Ratio
10-101R - All widths	1.0
10-20-1 - 18" to 36" width	1.333
10-20-1 - 42" to 72" width	1.407
10-30 - All widths	1.

Min: 0.001
 Max: 2.000
 Default: 1.000

A.2.3.7 Idler Spacing

The IDLER SPACING menu item allows you to enter the scale area idler spacing in feet or meters. Fractions cannot be entered. All measurements must be in decimal. Example: 42 ½ inch spacing = 3.542 feet.

Min: 0.001 ft
 Max: 999.999 ft
 Default: 3.000 ft

A.2.3.8 Idlers Number

The IDLERS NUMBER menu item allows you to enter the number of weigh idlers.

Min: 1
 Max: 6
 Default: 1

A.2.3.9 Conveyor Angle

The CONVEYOR ANGLE menu item allows you to enter the belt conveyor's angle of incline.

Min: -25.0 degrees
 Max: +25.0 degrees
 Default: 0.0 degrees

A.2.3.10 Calibration Constant R-Cal

The CALCON R-CAL menu item allows you to factor or change the constant after automatic calculation.

Min: 1
Max: 999.999
Default: 0

A.2.4 Input/Output (I/O Data) Menu

The I/O section of the Mini 11-101F is fully configurable. All inputs and outputs are conventionally numbered and can be assigned to physical input and output terminals to accommodate your specific needs.

Listed below are the items contained on the Input/Output menu. The procedure for completing the alarm definition scrolls is basically the same for each alarm. Access these scrolls by pressing **RUN/SET-UP** and **↓** until I/O DATA is displayed then press the **ENTER** key to access the I/O menu items and scroll through the menu items.

A.2.4.1 Defining Range mA - Output Range

The RANGE MA analog output represents 0-100% of the scale capacity. Choose the selection that represents your remote device output.

Selections: 4-20 mA
20-0 mA
20-4 mA
0-20 mA
Default: 4-20 mA

A.2.4.2 Defining Current Damping

The DAMPING menu item allows you to enter a time for the output to stabilize following a step change. This damping affects only the current output, not the displayed variable, which has a separate damping factor.

Min: 0 Sec
Max: 30 Sec
Default: 2 Sec

A.2.4.3 Defining Divide Out - Divisor for the Remote Counter

Divide out enables the pulse output for remote totalization to be factored to the master total in increments of 1, 10 or 100.

Example: Master total =100.0
Divide Out = 10
Each 10 counts = 1 pulse output

Selections: 1,10,100
Max: 100

A.2.4.4 Defining Pulse Width

The PULSE WIDTH menu item allows you to enter the minimum on time or pulse duration in seconds for the remote output relay. The entry should be rounded to steps of 1 mS.

Min: 0.010 S
Max: 0.300 S
Default: 0.100 S

A.2.4.5 Defining Speed Input (Input 1)

The INPUT 1 menu item monitors the belt speed and can either be Pulse or Simulated. Pulse is generated by a sensor on the conveyor belt, Simulated is generated by the frequency of your power input.

Selections: Pulse, Simulate
Default: Pulse

A.2.4.6 Defining Language

The LANGUAGE menu item allows you to select the language for display.

Selections: English or Spanish
Default: English

A.2.4.7 Defining Input 2

The INPUT 2 menu item allows you to select the function of digital input 2.

Selections: NOT USED
CLEAR TOTAL
BELT RUNNING
CLEAR ALARMS
AUTO ZERO
PRINT
CAL SWITCH
Default: CLEAR TOTAL

A.2.4.8 Defining Input 3

The INPUT 3 menu item allows you to select the function of digital input 3.

Selections: NOT USED
CLEAR TOTAL
BELT RUNNING
CLEAR ALARMS
AUTO ZERO
PRINT (OPTIONAL)
Default: CLEAR ALARMS

A.2.4.9 Defining Input 4

The INPUT4 menu item allows you to select the function of digital input 4.

Selections: NOT USED
CLEAR TOTAL
BELT RUNNING
CLEAR ALARMS
AUTO ZERO
PRINT (OPTIONAL)

Default: NOT USED

A.2.4.10 Defining Output 1

The OUTPUT 1 menu item allows you to select the function of digital output 1.

Selections: NOT USED
ALARM
INSTRUMENT READY
LOW RATE
HIGH RATE
TOTALIZER
FAIL

Default: INSTRUMENT READY

A.2.4.11 Defining Output 2

The OUTPUT 2 menu item allows you to select the function of digital output 2.

Selections: NOT USED
ALARM
INSTRUMENT READY
LOW RATE
HIGH RATE
TOTALIZER
FAIL

Default: ALARM

A.2.4.12 Defining Output 3

The OUTPUT 3 menu item allows you to select the function of digital output 3.

Selections: NOT USED
ALARM
INSTRUMENT READY
LOW RATE
HIGH RATE

TOTALIZER
FAIL
Default: TOTALIZER

A.2.4.13 Defining Output 4

The OUTPUT 4 menu item allows you to select the function of digital output 4.

Selections: NOT USED
ALARM
INSTRUMENT READY
LOW RATE
HIGH RATE
TOTALIZER
FAIL
Default: HIGH RATE

A.2.4.14 Defining Output 5

The OUTPUT 5 menu item allows you to select the function of digital output 5.

Selections: NOT USED
ALARM
INSTRUMENT READY
LOW RATE
HIGH RATE
TOTALIZER
FAIL
Default: NOT USED

A.2.4.15 Defining Alternate Rate Total - Alt. Rate-Tot

The ALT. RATE-TOT menu item displays alternates between total and rate. Entering 0 seconds disables this function.

Min: 0 Sec
Max: 20 Sec
Default: 0 Sec

A.2.4.16 Defining Data Format

The DATA FORMAT menu item elects the calendar format when the optional COMM board is installed.

Selection: MM-DD-YY
DD-MM-YY
Default: MM-DD-YY

A.2.5 Alarm Definition Menu

Mini 11-101F alarms are programmable. The alarm scrolls allow you to determine whether your Mini 11-101F will use the alarms. Access these scrolls by pressing **RUN/SET-UP**, moving to the display **ALARMS**, and pressing **ENTER**.

To set the parameters for the alarms see [A.2.2 Scale Data Menu](#).

When an alarm goes off, the Alarm LED flashes and the type of alarm displays and flashes on the screen. Each alarm can be reset if the alarm condition has been cleared using the **ENTER** key when the given alarm message is on the screen. To reset all of the alarms, press **ENTER** until the **NO ALARMS** message is displayed.

The procedure for completing the alarm definition scrolls is basically the same for each alarm. First you access the **ALARM** menu by pressing **RUN/SET-UP**, scroll until **ALARM** is displayed, and press **ENTER**.

The Alarms menu contains these items:

- **LOW RATE** - Low material flow rate
- **HIGH RATE** - High material flow rate
- **REM CNT OVRFL** - Remote Counter Overflow - remote totalizer
- **BELT PLS CNT OVF** - Belt Pulse Count Overflow -
- **COLD START** - Installs the default constants
- **LOAD CELL FAIL** - loss of load cell signal
- **MAX ZERO CORR** - Zero correction exceeds the range setting
- **MATH ERROR** - Incorrect set-up data is entered or a hardware fail

A.2.5.1 Low Rate

The **LOW RATE** menu item selects the function of the low rate alarm.

Selections: **NOT USED**
 ALARM
 FAIL

Default: **NOT USED**

A.2.5.2 High Rate

The **HIGH RATE** menu selects the function of the high rate alarm.

Selections: **NOT USED**
 ALARM
 FAIL

Default: **NOT USED**

A.2.5.3 Remote Counter Overflow (REM CNT OVRFL)

The REM CNT OVRFL menu item selects the function of the remote counter alarm overflow.

Selections: NOT USED
 ALARM
 FAIL

Default: ALARM

A.2.5.4 Belt Pulse Counter Overflow (BELT PLS CNT OVF)

The BELT PLS CNT OVF menu item selects the function of the belt pulse count alarm overflow.

Selections: NOT USED
 ALARM
 FAIL

Default: ALARM

A.2.5.5 Cold Start

The COLD START menu item selects the function of the cold start alarm.

Selections: NOT USED
 ALARM
 FAIL

Default: ALARM

A.2.5.6 Load Cell Fail

The LOAD CELL FAIL menu item selects the function of the load cell fail alarm.

Selections: NOT USED
 ALARM
 FAIL

Default: NOT USED

A.2.5.7 Max Zero Correction

The MAX ZERO CORRECTION menu item selects the function of the alarm max zero correction.

Selections: NOT USED
 ALARM
 FAIL

Default: ALARM

A.2.5.8 Math Error

The MATH ERROR menu item selects the function of the math error alarm.

Selections: NOT USED
ALARM
FAIL

Default: ALARM

A.2.6 Printer Scroll (Optional) Menu

The PRINTER SCROLL MENU provides access to the items used for configuring a serial communication board (COMM A) and for setting up serial printer output. These boards are optional with the Mini 11-101F Integrator.

The printer scrolls define the communication parameters for serial channels. All of the steps for each item in this procedure are the same and listed below.

A.2.6.1 Baud Rate

The BAUD RATE menu item allows you to specify the baud rate for the serial channel. This specifies the speed at which the data is transmitted.

Selections: 1200
2400
4800
9600
19200
38400

Default: 9600

A.2.6.2 Stop Bits

The STOP BITS menu item allows you to specify the number of stop bits used on the serial channel.

Selections: 1 and 2

Default: 1

A.2.6.3 Parity

The PARITY menu item allows you to specify the parity used on the serial channel.

Selections: ODD
EVEN
NOT USED

Default: EVEN

A.2.6.4 Word Length

The WORD LENGTH menu item allows you to specify the number of data bits (word length) used on the serial channel.

Selections: 7 and 8
Default: 8

A.2.6.5 Handshake

The HANDSHAKE menu items allows you to specify the handshaking with the remote serial device.

Selections: NOT USED
CTS
XON-XOFF
Default: NOT USED

A.2.6.6 End of Line

The END OF LINE menu item allows you to select the combination of characters at end of line of the serial printer. Select the pattern you need for your device.

Selections: CR, LF, CR+LF
Default: CR+LF

A.2.6.7 Delay End of Line

Some printers cannot accept characters while they are printing, so the handshake is not controlled well. A DELAY AT END-OF-LINE can help.

Selections: 0–5 seconds
Default: 0 seconds

A.2.6.8 Print Interval

The PRINT INTERVAL menu item allows you to specify the interval of time between automatic printouts of the totals. When 0 is entered, automatic printing is not performed.

Selections: 0–127 minutes
Default: 0

A.2.6.9 Report Format

There are two ways of defining the print format for your totals reports: use the predefined default format or define your own format using the printer setup procedures described in this section.

Selections: DEFAULT, USER DEFINED
Default: DEFAULT

The default format is as follows:

DATE	09-19-00
TIME	02:40:35
RATE	133.5 TPH
MASTER TOTAL	239961.2 Ton
RESET TOTAL	0

If the USER DEFINED report is selected, the following menus will be displayed and must be defined.

A.2.6.10 String #1

STRING #1 defines if the first optional alphanumeric string has to be included into the print report.

Selections: YES, NO
Default: NO

A.2.6.11 Contents String #1

CONTENTS STRING #1 defines the first optional alphanumeric string.

Selections: Any String
Default: XXXXXXXXXXXXXXXXXXXX

A.2.6.12 String #1 Position

STRING #1 POSITION defines row and column of the first optional alphanumeric string.

Selections: CC, RR
Default: 01 01

A.2.6.13 String #2

STRING #2 defines if the second optional alphanumeric string has to be included into the print report.

Selections: YES, NO
Default: NO

A.2.6.14 Contents String #2

CONTENTS STRING #2 defines the second optional alphanumeric string.

Selections: Any String
 Default: XXXXXXXXXXXXXXXXXXXX

A.2.6.15 String #2 Position

STRING #2 POSITION defines row and column of the second optional alphanumeric string.

Selections: CC, RR
 Default: 01 02

A.2.6.16 String #3

STRING #3 defines if the third optional alphanumeric string has to be included into the print report.

Selections: YES, NO
 Default: NO

A.2.6.17 Contents String #3

CONTENTS STRING #3 defines the third optional alphanumeric string.

Selections: Any String
 Default: XXXXXXXXXXXXXXXXXXXX

A.2.6.18 String #3 Position

STRING #3 POSITION defines row and column of the third optional alphanumeric string.

Selections: CC, RR
 Default: 01 03

A.2.6.19 Rate Position

RATE POSITION defines row and column of the rate.

Selections: CC RR
 Default: 01 04

A.2.6.20 Master Total Position (Mtotal Pos)

MTOTAL POS defines row and column of the master total.

Selections: CC RR
 Default: 01 05

A.2.6.21 Reset Total Position (Rtotal POS)

RTOTAL POS defines row and column of the reset total.

Selections: CC RR
Default: 01 06

A.2.6.22 Date Position

DATE POSITION defines row and column of the date.

Selections: CC RR
Default: 01 07

A.2.6.23 Time Position

TIME POSITION defines row and column of the time.

Selections: CC RR
Default: 01 08

A.2.7 Test Menu

At the TEST menu you can set passwords, perform service diagnostics, and integrator self tests.

A.2.7.1 Setting Up Passwords

The Mini 11-101F allows you to define protection levels and associate passwords with them to guard against unauthorized changes to operating parameters. At this menu you designate a password. You have to activate the password at the Protection menu.

Access this scroll by pressing **RUN/SET-UP** and scrolling until the display reads **TEST** and press **ENTER** until the screen flashes.

Enter a desired password. Record this password and store in a safe place. To activate the password you must return to the Protection menu and follow these procedures.

1. Press **RUN/SET-UP**
PROTECTION displays
2. Press **ENTER**
NOT ACTIVE should display
3. Press **ENTER** until the display flashes.
You will be asked to enter the password you just selected in Section [A.2.7.1 Setting Up Passwords](#).
4. Press the arrow keys to scroll through the numerical places and enter your designated password.
5. Press **ENTER** and select ACTIVE
6. Press **ENTER** to save the selection
7. Press **RUN/SET-UP** to return the integrator to Run mode.

A.2.7.2 Displaying Raw A/D Data (A/D Gross)

The A/D GROSS display shows the analog/digital converter gross which is the total weight on the load cells. To access this display do the following:

Move to A/D GROSS and press **ENTER**.

A.2.7.3 Displaying Raw A/D Data (A/D Net)

A/D NET is the analog/digital converter gross after the zero constant has been subtracted. It indicates the weight on the load cell.

Move to A/D NET and press **ENTER**.

A.2.7.4 Displaying Pulse per Minute (PLS/Min)

The PLS/MIN displays the pulse per minute of the designated speed sensor. The values were set up in the I/O (Input/Output) menu at the SPEED INPUT selection.

Move to the PLS/MIN and press **ENTER**.

A.2.7.5 Displaying Belt Speed (SP)

The SP menu item displays the current speed of the belt and is displayed in distance/time.

Move to SP and press **ENTER**.

A.2.7.6 Displaying Belt Loading (PS)

The PS menu item displays the wt/distance of the load on the load cell.

Move to PS and press **ENTER**.

A.2.7.7 Displaying Load Cell Output (LC SUP)

The LC SUP menu item displays the mV output of the load cell. The load cell output will change depending on the load.

Move to the LC SUP and press **ENTER**.

A.2.7.8 Displaying Correction Zero (C_Zero)

Correction Zero is used to trim the minimum value of the analog output. The value can be changed at this menu. Values manually entered are adjusted back to zero when a scale auto zero test is performed.

1. Move to C_ZERO and press **ENTER**, the current value displays.
2. Press the arrow keys to enter a changed value.
3. Press **ENTER** to save the changes.
4. Move to the next menu item.

A.2.7.9 Displaying Correction Span (C_Span)

The C_SPAN menu item sets the parameters or acceptable range for the analog output.

1. Move to C_SPAN and press **ENTER**, the current value displays.
2. Press the arrow keys to enter a changed value.
3. Press **ENTER** to save the changes.
4. Move to the next menu item.

A.2.7.10 Displaying the Software Version (Softwar Ver)

The current SOFTWARE VER in the Mini 11-101F is displayed for reference only on the TEST scroll.

Move to SOFTWARE VER and press **ENTER**.

A.2.7.11 Testing Memory

MEMORY TEST is a self diagnostics test that tests the Random Access Memory (RAM) of the Mini 11-101F Integrator.

Move to MEMORY TEST and press **ENTER**, RAM OK displays.

A.2.7.12 Testing Input

The TESTING INPUT diagnostic procedure tests the digital inputs and indicates if the inputs you entered in the I/O MENU are open or closed (on or off). (See [A.2.4.7 Defining Input 2.](#))

1. Move to INPUT TEST and press **ENTER**. The display shows all three inputs at one time. (**Example:** INPUTS 010).

The first digit on the right of the display refers to input 3, the second digit from the right refers to input 2 and so on.

If an input displays 0, it indicates the input is open (off). If it displays a 1, it indicates the input is closed (on).

2. Move to the next menu item.

A.2.7.13 Testing Output

The TESTING OUTPUT diagnostic procedure tests the digital outputs and indicates if the outputs you entered in the I/O MENU are open or closed (on or off). (See [A.2.4.10 Defining Output 1.](#))

1. Move to OUTPUT TEST and press **ENTER**. The display shows all five outputs at one time. (**Example:** OUTPUTS 10010).

The first digit on the right of the display refers to input 5, the second digit from the right refers to input 4, and so on.

If an input displays 0, it indicates the input is open (off). If it displays a 1, it indicates the input is closed (on).

2. Move to the next menu item.

A.2.7.14 Lamp Test

The LAMP TEST menu item tests the lamp in the LED display area.

Move to LAMP TEST and press **ENTER**. All LEDs and digits of the display should blink for a number of seconds.

A.2.7.15 Entering a Forced Value

The FORCE VALUE menu item allows you to enter a forced value of wt/time for testing or calibrating remote equipment.

1. Move to FORCE VALUE and press **ENTER**.
2. Press the arrow keys to enter the desired value, press **ENTER** to save your entry.

A.2.7.16 Setting the Time (Optional COMM Board)

The TIME procedure is done only if there is a COMM board installed. Begin this procedure at the TEST menu.

1. Scroll to TIME 00:00:00, press **ENTER**.
2. Press the arrow keys to enter the correct time in hours, minutes, and seconds.
3. Press **ENTER** to save.
4. Move to the next menu item.

A.2.7.17 Setting the Date (Optional COMM Board)

The DATE procedure is done only if there is a COMM board installed. Begin this procedure at the TEST menu.

1. Scroll to DATE 00-00-00, press **ENTER**.
2. Press the arrow keys to enter the correct date in months, days and years.
3. Press **ENTER** to save.
4. Press **RUN/SET-UP** to return the integrator to Run mode.

A.3 Permanent Scroll Record for Set-Up Scrolls

Following zero and span calibration, the *Permanent Scroll Record* should be completed. This record is useful for trouble shooting if the need arises. Test scroll entries should be recorded when the conveyor is running empty. A variable speed belt should be running at maximum speed during calibration and when recording data. If the scale system has static test weights, record the Test scroll readings with the weights applied in addition to empty.

Scale Data Scroll	Data
1. Scale Units	
2. Decimal Place	
3. Scale Capacity	
4. Load Cell Capacity	
5. Number of Load Cells	
6. Filter	
7. Low Rate Set	
8. High Rate Set	
9. Rate Alarm Delay	
10. Auto Zero Tracking Range	
11. AutoZero Track Limit	
12. Dead Band	

Calibration Data Scroll	Data
1. Calibration Mode	
2. R-CAL Mode	
3. Load cell MV/V	
4. Load Cell Resistance	
5. R-CAL Resistance	
6. Weigh bridge Lever Ratio	
7. Idler Spacing	
8. Number of Weigh Idlers	
9. Conveyor Angle	
10.Calcon R-CAL	

I/O Data Scroll	Data
1. Current Output Range mA	
2. Current Output Damping	
3. Divide Out	
4. Pulse Width	
5. Speed Input	
6. Language	
7. Input 2	
8. Input 3	
9. Input 4	
10.Output 1	
11.Output 2	
12.Output 3	
13.Output 4	
14.Output 5	
15.Alternate - Rate & Total	
16.Data Format	

Alarms Scroll	Data
1. Low Rate	
2. High Rate	
3. Remote Counter Overflow	
4. Belt Pulse Counter Overflow	
5. Cold Start	
6. Load Cell Fail	
7. Maximum Zero Correction	
8. Math Error	

Optional Print Scroll	Data
1. Baud Rate	
2. Stop Bits	
3. Parity	
4. Word Length	
5. Handshake	
6. End of Line	
7. Delay End of Line	
8. Print Interval	
9. Report Format	
10. String #1	
11. Contents String #1	
12. String #1 Position	
13. String #2	
14. Contents String #2	
15. String #2 Position	
16. String 32	
17. Contents String #3	
18. String #3 Position	

Optional Print Scroll	Data
19. Master Total Position	
20. Reset Total Position	
21. Date Position	
22. Time Position	

Test Scroll	Data
1. Password	
2. A/D Gross	
3. A/D Net	
4. Speed Pulses/Min.	
5. Belt Speed	
6. Belt Loading	
7. Load Cell Signal mV	
8. Correction Zero	
9. Correction Span	
10. Software Version	

Calibration Scroll	Data
1. Test Duration Length	
2. Test Duration Pulses	
3. Speed Pulses Pre-scale	
4. Manual Zero	
5. Manual Span	

Appendix B

Appendix B Mini 11-101F Integrator Menu Trees

B.1 Overview

This appendix contains an overview of the Mini 11-101F Integrator menu items, their description and/or their default settings. The menus listed are:

- Run Menu
- Calibration Menu
- Input/Output Menu
- Alarms Menu
- Test Menu
- Print Menu (Optional with the Comm board installed)

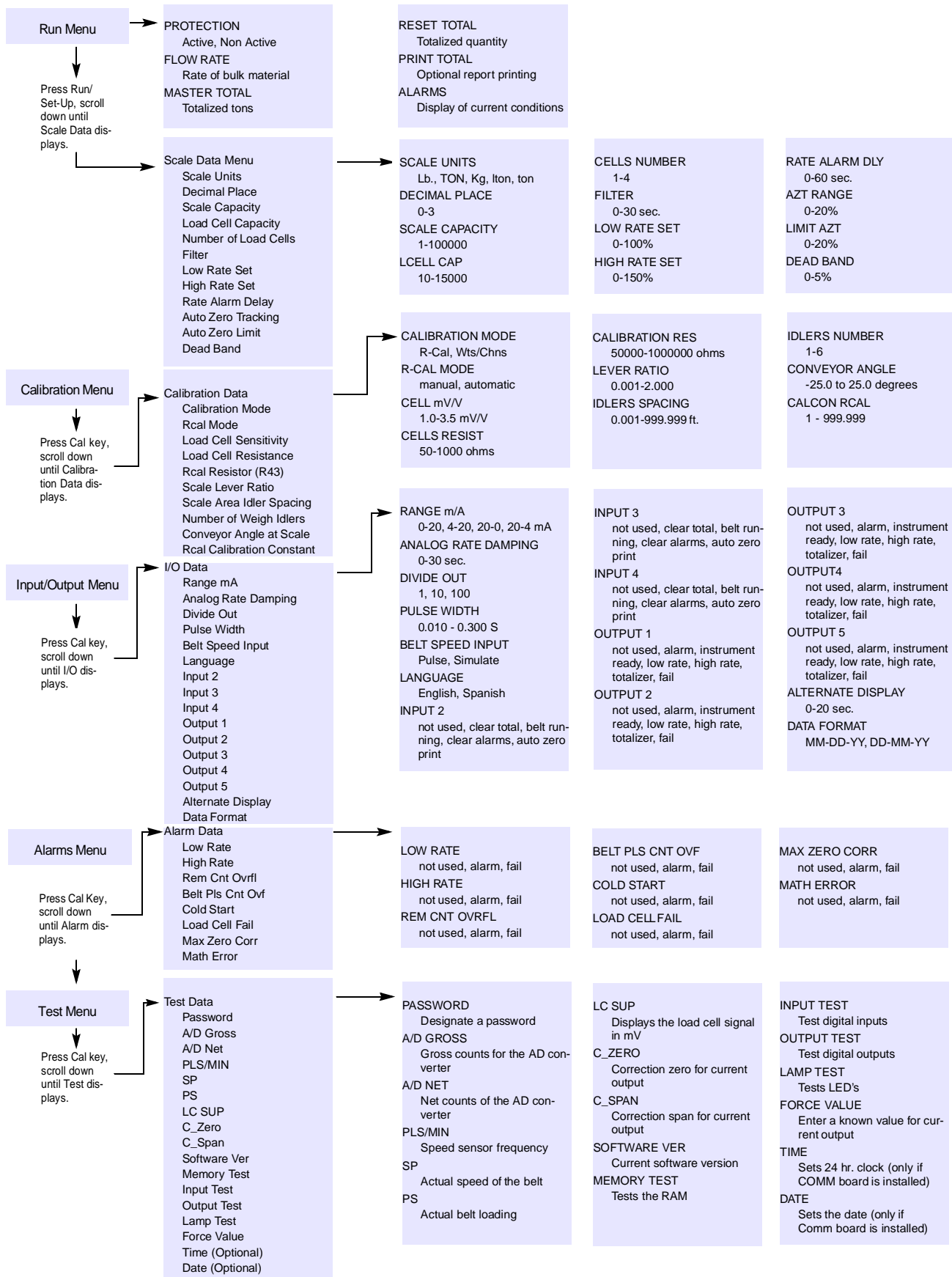

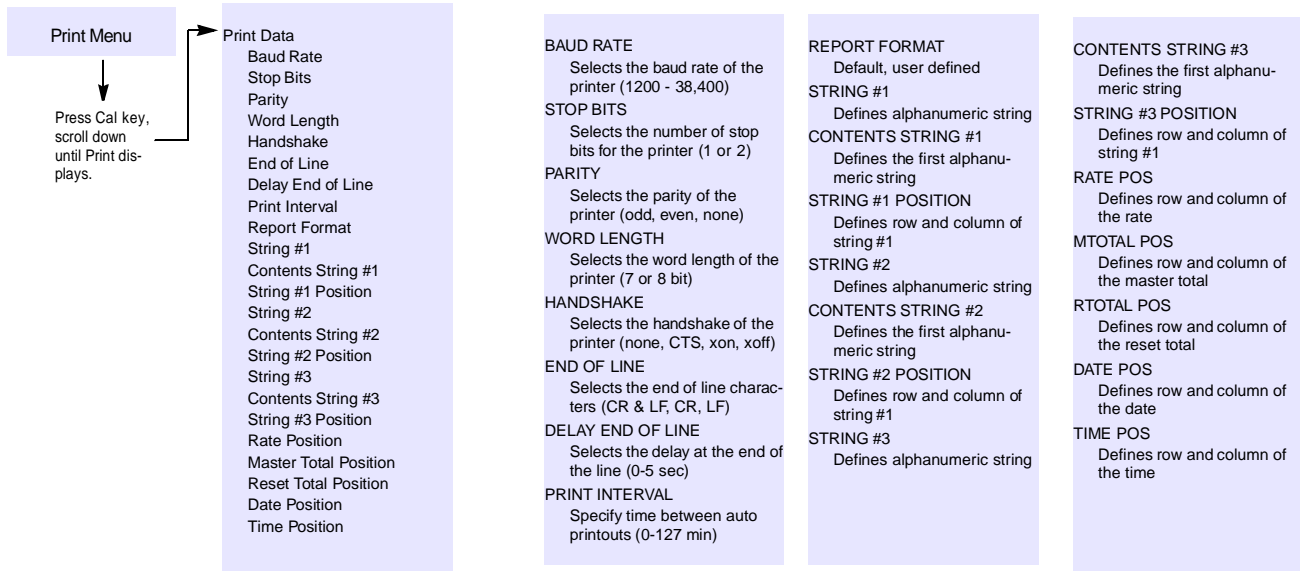

Appendix C

Appendix C Mini 11-101F Integrator Engineering Drawings

C.1 Overview

This appendix contains the engineering drawings and field wiring diagrams for the Mini 11-101F Integrator.

The following drawings are included:

- Field Wiring Diagram (D07286A-Y009)

Figure C-1. Field Wiring Diagram

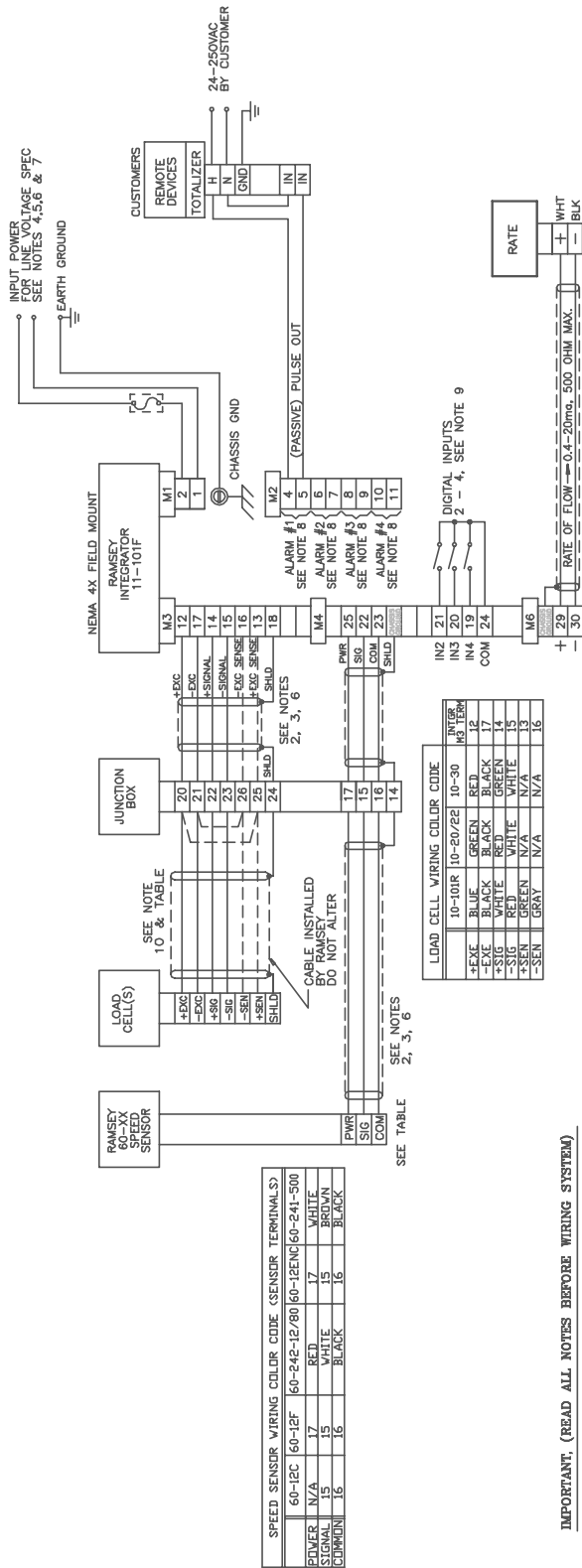

IMPORTANT. (READ ALL NOTES BEFORE WIRING SYSTEM)

NOTE:

- 1 DO NOT ALTER LENGTH OF CABLE SUPPLIED WITH LOADCELL.
- 2 USE BELDEN 8407 (RAMSEY P/N 003727) OR EQUIVALENT, 4 CONDUCTOR, 16 AWG, SHIELDED IF TOTAL LENGTH IS OVER 200 FEET. USE BELDEN 8780 (RAMSEY P/N 003236), 2 CONDUCTOR, 16 AWG, SHIELDED IF TOTAL LENGTH IS OVER 200 FEET. WHEN EXTERNAL SENSE IS REQUIRED, REMOVE JUMPERS S1 AND S2. INTERNAL TO 11-101F AND INSTALL JUMPERS IN JUNCTION BOX AS SHOWN.
- 3 SPEED SENSOR AND ANALOG OUTPUTS - USE BELDEN 8760 (RAMSEY P/N 003249) OR EQUIVALENT, 2 CONDUCTOR, 18 AWG, SHIELDED IF TOTAL IS 200 FEET OR LESS. USE BELDEN 8780 (RAMSEY P/N 003236), 2 CONDUCTOR, 16 AWG, SHIELDED IF TOTAL LENGTH IS 201 TO 3,000 FEET.
- 4 3 CONDUCTOR SPEED SENSOR CABLE (POWERED SENSORS - REFER TO SPEED SENSOR MANUAL), USE BELDEN 8760 (RAMSEY P/N 003249) OR EQUIVALENT, 3 CONDUCTOR, 18 AWG, SHIELDED IF TOTAL LENGTH IS 300 TO 3,000 FEET.
- 5 DO NOT RUN SIGNAL, LOADCELL, OR SPEED SENSOR CABLES IN SAME CONDUIT AS POWER WIRING. CONNECT SHIELDS ONLY WHERE SHOWN.
- 6 INPUT POWER REQUIREMENTS (FACTORY SET AT 110 VAC)
 - A. 110 VAC +10%/-15% 1/2 AMP 50 VA50/60HZ
 - B. 220 VAC +10%/-15% 1/4 AMP 50 VA50/60HZ
- 6 EARTH GROUND ALL ELECTRICAL ENCLOSURES.
- 7 ALL WIRING MUST BE IN ACCORDANCE WITH THE NATIONAL ELECTRIC CODE AND ALL LOCAL CODES. ALL WIRING, EXCEPT AS NOTED, IS THE RESPONSIBILITY OF THE CUSTOMER.
- 8 N.O. CONTACTS RATED .5 AMP @ 250 VAC. CAN BE CONFIGURED FOR PULSE OUTPUT, ALARM, INSTRUMENT READY, LOW RATE, HIGH RATE OR NOT USED. SEE MANUAL.
- 9 DIGITAL INPUTS CAN BE CONFIGURED FOR CLEAR TOTAL, BELT RUNNING, CLEAR ALARMS, AUTO ZERO, PRINT (OPT) OR NOT USED. SEE MANUAL.
- 10 FOR MULTIPLE LOAD CELL SYSTEMS, TERMINATE BOTH LOAD CELL CABLES AT THE SAME POINTS IN THE SCALE JUNCTION BOX.

REC 3968 Rev. G
Part No. 051033

Thermo Ramsey