

Oretronic III
Tramp Metal Dector
Operating & Service Manual

REC 4105, Rev. J Part Number 060298-English

Revision History

Revision Number	Date Released	ECO Number	Release Specifics
Revision A	July 2000		Manual released. This revision documents version 1..01 of the Oretronic III Tramp Metal Detector Software
Revision B	October 2000		Manual revised to add information about the underbelt single coil model and remote front panel.
Revision C	January 2002		This revision documents version 1.04 of the Oretronic III Tramp Metal Detector software. Manual revised to add information about Electronically Simulated Tramp (EST) optional system and UL updates.
Revision D	November 2002		This revision documents changes for software version 1.05. Maximum clips delay extended to 30 feet.
Revision E	August 2003	3497	This revision documents changes for software version 1.06 Auto Zero or F5 disabled after control alarms on tramp, or if in calibrate mode. F5 can be disabled by turning on SW1-7.
Revision F	January 2005	0516	Revise errors
Revision G	June 2005	0641	Revise errors
Revision H	May 2007	1392	This revision makes name changes to Thermo Fisher Scientific.
Revision J	December 2009	2180	Rebrand and upgrade format

©2009 Thermo Fisher Scientific. All rights reserved.

This document is confidential and is the property of Thermo Fisher Scientific (Thermo Scientific). It may not be copied or reproduced in any way without the express written consent of Thermo Scientific. This document also is an unpublished work of Thermo Scientific. Thermo Scientific intends to, and is maintaining the work as confidential information. Thermo Scientific also may seek to protect this work as an unpublished copyright. In the event of either inadvertent or deliberate publication, Thermo Scientific intends to enforce its rights to this work under the copyright laws as a published work. Those having access to this work may not copy, use, or disclose the information in this work unless expressly authorized by Thermo Scientific.

“Microsoft” and “Windows” are either registered trademarks or trademarks of Microsoft Corporation in the United States and/or other countries.

All other trademarks are the property of Thermo Fisher Scientific and its subsidiaries.

About this Manual

This manual provides the information you need to install, operate, and maintain the Oretronic III Tramp Metal Detector (TMD). This revision documents version 1.06 of TMD software.

Read this manual before working with the system. For personal and system safety, and for the best product performance, make sure you thoroughly understand the manual before installing, operating, or maintaining this machine.

Safety Messages

Instructions in this manual may require special precautions to ensure the safety of the personnel performing the operations.

Potential safety issues are indicated by this symbol:

Please read the safety information before performing any operation preceded by this symbol.

There are two levels of safety messages: warnings and cautions. The distinction between the two is as follows:

 WARNING
Failure to observe could result in death or serious injury.

 CAUTION
Failure to observe may cause minor injury or damage the equipment

General Precaution

Do not install, operate, or perform any maintenance procedures until you have read the safety precautions presented below.



WARNING

Failure to follow safe installation and servicing procedures could result in death or serious injury.

- Make sure only qualified personnel perform installation and maintenance procedures in accordance with the instructions in this manual.
- Allow only qualified electricians to open and work in the electronics cabinet, power supply cabinet, control cabinets, or switch boxes.
- Covers over the electronics and rotating parts must always remain in place during normal operation. Remove only for maintenance, with the machine's power OFF. Replace all covers before resuming operation.
- During maintenance, a safety tag (not supplied by the factory) is to be displayed in the ON/OFF switch areas instructing others not to operate the unit (ANSI:B157.1).



WARNING

High voltage that may be present on leads could cause electrical shock.

- All switches must be OFF when checking input AC electrical connections, removing or inserting printed circuit boards, or attaching voltmeters to the system.
- Use extreme caution when testing in, on, or around the electronics cabinet, PC boards, or modules. There are voltages in excess of 115 V or 230 V in these areas.



WARNING

Use only the procedures and new parts specifically referenced in this manual to ensure specification performance and certification compliance. Unauthorized procedures or parts can render the instrument dangerous to life, limb, or property.

**CAUTION**

Keep hands and clothing away from all moving or rotating parts.

**CAUTION**

Do not place or store objects of any kind on the machine.

**CAUTION**

This machine should not be operated at more than the production rate stated on your Equipment Specification sheet or used in applications other than those stated in the original order.

Contents

Chapter 1 Introduction.....	1-1
Overview	1-1
Theory of Operation.....	1-1
System Components	1-4
Support Structure & Coils	1-6
Control Unit.....	1-7
Features and Options	1-7
Simplified Operator Interface	1-7
Remote Front Panel.....	1-8
Synchronization of Transmitter Pulses.....	1-8
Speed Sensor	1-8
Clip Detector	1-8
High Pile Detector	1-9
Timed Delay Marker	1-9
System Requirements	1-9
Technical Specifications	1-10
Chapter 2 Installing the TMD.....	2-1
Overview	2-1
Installation Considerations	2-1
Mounting Location	2-2
Electrical Specifications.....	2-2
Input Power Requirements	2-2
Safety Precautions	2-3
Equipment Handling	2-4
Inspection and Unpacking	2-4
Inspection and Unpacking	2-4
Installing the TMD.....	2-4
Installing the Coil Support Structure and Coils for a Dual Coil TMD	2-4
Installing the Coil Support Structure and Coil for an Under Belt Single Coil TMD	2-5
Installing System Devices	2-6
Mounting the Control Unit	2-7
Field Wiring the TMD	2-9
Critical Wiring Conditions	2-9
Field Wiring Procedure.....	2-10
Connecting Incoming Power.....	2-11
Configuring the TMD	2-12
DIP Switch Settings	2-12
CPU Board Switch Settings	2-13
Initial Power On	2-15

Calibrating the Speed Sensor	2-16
Determining Values to Use for Initial Setup.....	2-16
Determining Belt Speed.....	2-17
Determining Clip Delay.....	2-17
Determining Timed Delay	2-17
Chapter 3 Operating the TMD	3-1
Overview	3-1
Operator Interface	3-1
Operating Modes.....	3-2
Menu Structure.....	3-2
Front Panel Keypad.....	3-4
SCROLL Keys	3-4
VALUE Keys	3-4
ENTER Key	3-4
RESET Key.....	3-5
Front Panel LED Indicators	3-5
NORMAL	3-5
ALARM	3-5
BYPASS	3-5
CALIB	3-5
Bar Graph	3-5
Front Panel Displays	3-6
Run Screen.....	3-6
Password Protection Screen.....	3-7
Calibration Screens	3-8
Coil Balance.....	3-8
Calibrate for Metal	3-9
Calibrate for Clip	3-9
EST Cal	3-10
Test.....	3-10
Exit.....	3-11
Setup Screens	3-11
Clip Delay	3-11
Bar/Rod Sensitivity	3-11
Bar/Rod Length.....	3-12
Belt Speed	3-12
Timed Delay.....	3-12
Timed Duration	3-12
Audit Int.....	3-12
Material Code	3-12
Time Constant	3-12
Filter.....	3-13
Operating Frequency	3-13
Remote Front Panel.....	3-13
Modbus Communications	3-13
Switch Settings	3-13

Front Panel Tests.....	3-14
Software Version.....	3-14
Exit.....	3-14
Error Messages.....	3-14
Error Conditions	3-14
Fault Conditions	3-15
Setting up the TMD.....	3-16
Before You Begin.....	3-16
Using the Display Scroll	3-17
Entering Values	3-17
Initial Setup Procedure.....	3-17
Chapter 4 Maintaining & Troubleshooting	4-1
Overview	4-1
Routine Maintenance.....	4-1
Troubleshooting.....	4-2
Visual Inspection.....	4-2
Diagnosing and Correcting Problems	4-3
False Tripping.....	4-4
Correcting Coil Imbalance.....	4-4
Finding the Source of Mechanical or Electrical Noise	4-7
Adjusting for High Product Noise (Mineral Ores)	4-10
Adjusting for Bar/Rod Detection.....	4-12
Adjusting for Clip (Belt Splice) Detection	4-13
Passing Tramp Undetected	4-17
Adjusting Metal Sensitivity	4-17
Changing the Material Type Code to Adjust Sensitivity ..	4-19
Testing for Coil or Junction Box Damage.....	4-20
Testing the Transmitter Coil	4-22
Testing the Receiver Coil	4-22
Determining TMD Malfunction	4-23
Passing Bars or Rods Undetected.....	4-27
Installing Default Values	4-28
Error Messages	4-29
Error Conditions.....	4-29
Fault Conditions.....	4-30
Chapter 5 Service, Repair, & Replacement Parts	5-1
Service and Repair Information	5-1
Parts Ordering Information	5-2
Parts Lists.....	5-2
Disposal of Hazardous Waste	5-7
Appendix A - TMD Modbus Interface.....	A-1
Overview of TMD Communications.....	A-1
Modbus Message Types Supported by the TMD.....	A-1
Example: Read Holding Registers	A-2
Example: Preset Multiple Registers	A-2

Exception Responses.....	A-3
Master/Slave Timing Considerations	A-3
TMD Holding Registers	A-3

Appendix B - Remote Front PanelB-1

Overview.....	B-1
Routine Maintenance.....	B-1
Technical Specifications.....	B-2
Installing the Remote Front Panel	B-3
Mounting the Remote Front Panel	B-4
Field Wiring the Remote Front Panel	B-6
Input Power Requirements	B-6
Critical Wiring Conditions.....	B-6
Field Wiring Procedure.....	B-7
Setting the Comm Switches	B-9
Setting up and Operating the Remote Front Panel	B-9
Parts List.....	B-10

Appendix C - Electronically Simulated Tramp (EST) C-1

Theory of Operation.....	C-1
Mechanical Installation	C-1
Electrical Installation	C-2
Calibration and Setup	C-2
Interval Setup.....	C-2
Last EST (EST Last).....	C-3
EST Test (EST Test)	C-3

Appendix D Engineering Drawings..... D-1

List of Figures

Figure 1–1. Magnetic Fields Generated by the TMD	1-2
Figure 1–2. How Conductivity Affects Decay Time	1-2
Figure 1–3. Ore/Tramp Metal Decay Time Comparison.....	1-3
Figure 1–4. Measurement Window Timing.....	1-3
Figure 1–5. Signal Sensitivity/Measurement Timing Adjustment	1-4
Figure 1–6. TMD System Components: Dual Coil	1-5
Figure 1–7. TMD System Components: Under Belt Single Coil	1-6
Figure 1–8. Oretronic III Control Unit	1-7
Figure 2–1. Control Unit Mounting Dimensions.....	2-7
Figure 2–2. Control Unit Enclosure - Bottom View.....	2-8
Figure 2–3. Terminal Block Locations on the CPU Board.....	2-10
Figure 2–4. Switch Locations on the CPU Board.....	2-14
Figure 3–1. Tramp Metal Detector Front Panel.....	3-2
Figure 3–2. TMD Menu Tree.....	3-3
Figure 4–1. Terminals on the CPU Board	4-21
Figure B–1. Remote Front Panel Dimensions	B-5
Figure B–2. Interior of the Remote Front Panel Enclosure	B-7

List of Tables

Table 2–1. SW1 DIP Switch Settings	2-13
Table 2–2. CPU Board Switch Settings.....	2-15
Table 2–3. Comm Switch SW4 Settings.....	2-15
Table 3–1. Error Messages	3-15
Table 3–2. Fault Messages.....	3-16
Table 4–1. Error Messages	4-30
Table 4–2. Fault Messages.....	4-31
Table A–1. TMD Exception Responses.....	A-3
Table B–1. Comm Switch Settings.....	B-9

Chapter 1 Introduction

This chapter introduces the Oretronic III Tramp Metal Detector (TMD). It gives an overview of the device's capabilities, describes its basic functionality, and lists its technical specifications.

Overview

The Oretronic III Tramp Metal Detector (TMD) detects the presence of tramp metal in bulk material being transported on a conveyor belt. Detected tramp metal can then be removed from the process stream manually or automatically by mechanical means. Removing the tramp metal protects crushers, material handlers, and process equipment from the damage it may cause.

This highly reliable system detects all types of tramp metal that could be found in bulk material on belt conveyors even when it is buried in wet, conductive materials. Tramp metal could include such things as bucket teeth, manganese steel mantles, bore crowns, bar scrap, chains, and tools. The bulk material (or burden) can be product such as iron pellets, minerals, aggregates, coal, or coke.

The Oretronic III TMD can be installed on conveyors with speeds up to 1,200 ft/min (6.1 m/s). In addition, because it is insensitive to materials with high magnetic permeability and electrical conductivity, this detector can be used in applications where conventional metal detectors produce an unacceptable false alarm rate.

The Oretronic III TMD has a microprocessor-based control unit that automates system setup and calibration. The operator interface provides easy-to-read indicators, a touch panel keypad designed to simplify setting up, and maintaining the system.

Theory of Operation

The TMD operates by generating a pulsed magnetic field (the primary magnetic field) that is radiated from its transmitter coil. This field generates an output signal in the receiver coil (see Figure 1-1).

When the pulse is turned off, eddy currents induced in tramp metal produce a secondary magnetic field. This new field also generates an output signal in the receiver coil. The detector measures the effect of this secondary magnetic field only during the time the primary field is inoperative.

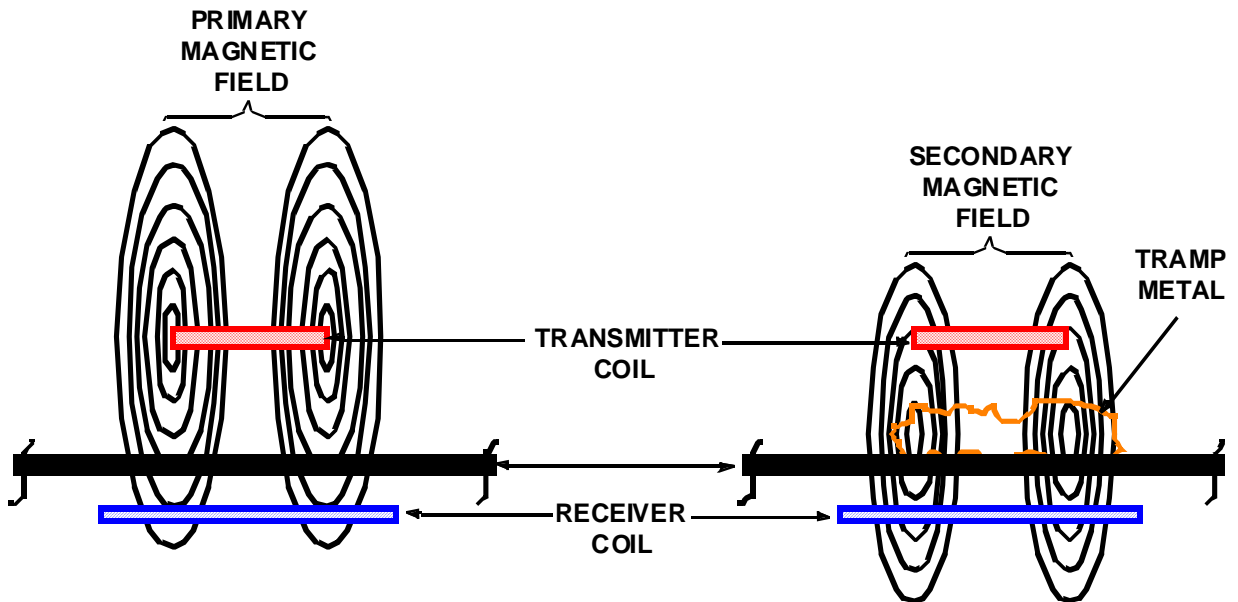

Figure 1-1. Magnetic Fields Generated by the TMD

The material on the conveyor belt also produces a secondary magnetic field. The two magnetic fields can be distinguished from each other by observing their decay times. The better the conductivity characteristics of the material, the longer the decay time. As the magnetic field decays, the output signal strength decreases (see Figure 1-2).

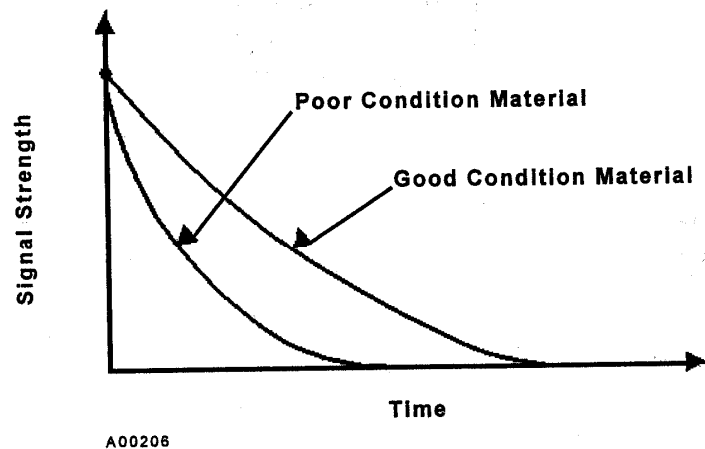
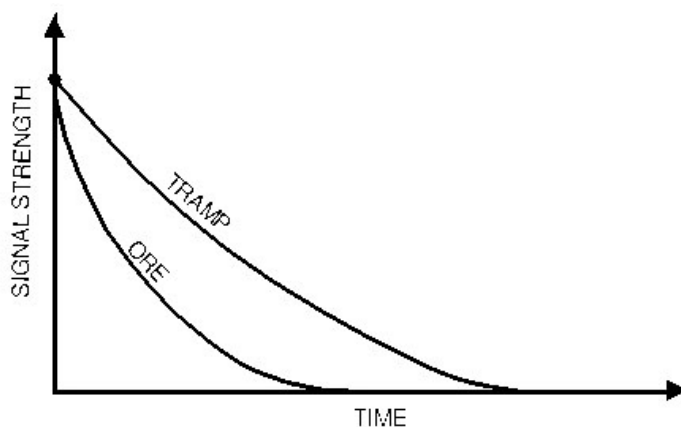

Figure 1-2. How Conductivity Affects Decay Time

Coal, aggregate, and mineral ores have conductivity characteristics considerably poorer than tramp metal, which means their magnetic field decays more quickly (see Figure 1-3).



A00207

Figure 1–3. Ore/Tramp Metal Decay Time Comparison

The Oretronic III TMD is designed to take advantage of the difference in decay time by activating its measurement window (the point at which it reads the output signal) only after the magnetic field from the material on the conveyor has decayed and before the tramp's decay has ended (see Figure 1-4). Using this measurement window timing helps prevent both false trips and passed tramp metal.

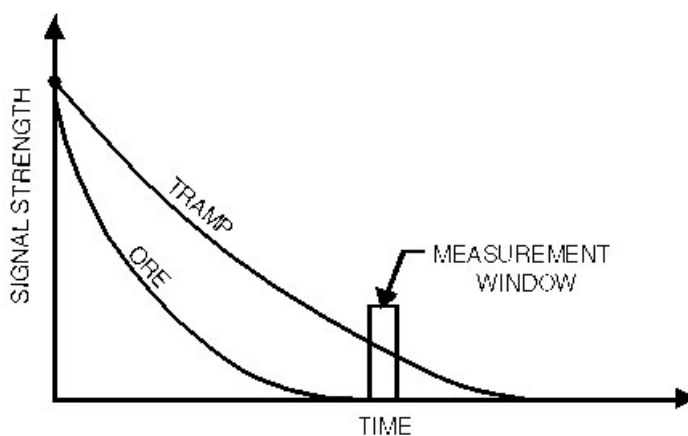

A00208

Figure 1–4. Measurement Window Timing

The Oretronic III TMD allows you to adjust both the sensitivity of the device to output signals and the location of the measurement window in the decay time. Signal strength is adjusted by a sensitivity factor; the measurement-timing window is adjusted based on a material type code factor. (See Figure 1-5).

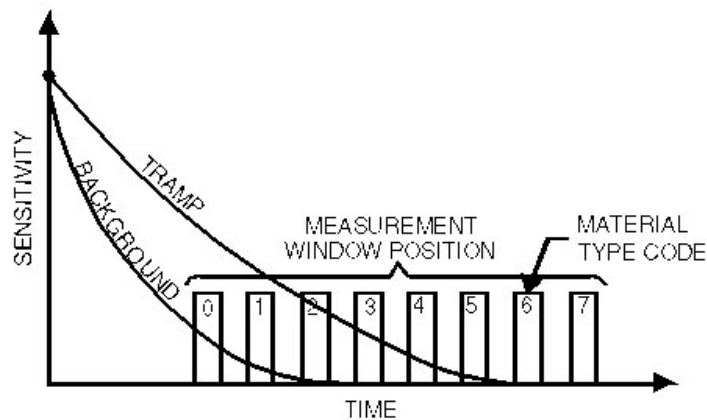

A00209

Figure 1-5. Signal Sensitivity/Measurement Timing Adjustment

System Components

There are two models of the Oretronic III TMD: dual coil and under belt single coil. The “standard” dual coil TMD has a transmitter coil mounted above the belt and a receiver coil mounted under the belt. The under belt single coil TMD is physically different but functionally similar to a standard model. On an under belt single coil TMD, the transmitter and receiver coils are together in a coil assembly mounted under the belt.

This section describes the major components of a TMD system.

Figure 1-6 shows the components and system options for a dual coil TMD. Figure 1-7 shows the components and system options for an under belt single coil TMD.

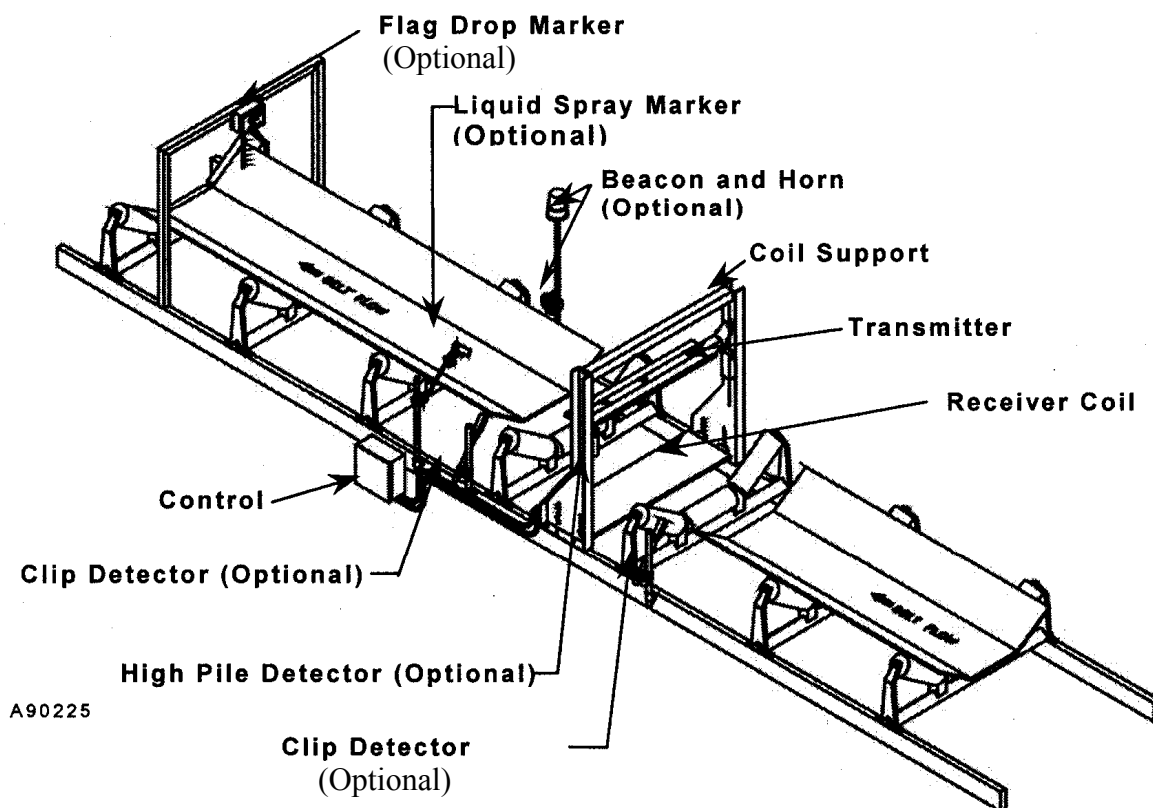
Figure 1-6: TMD System Components: Dual Coil**Figure 1-6. TMD System Components: Dual Coil**

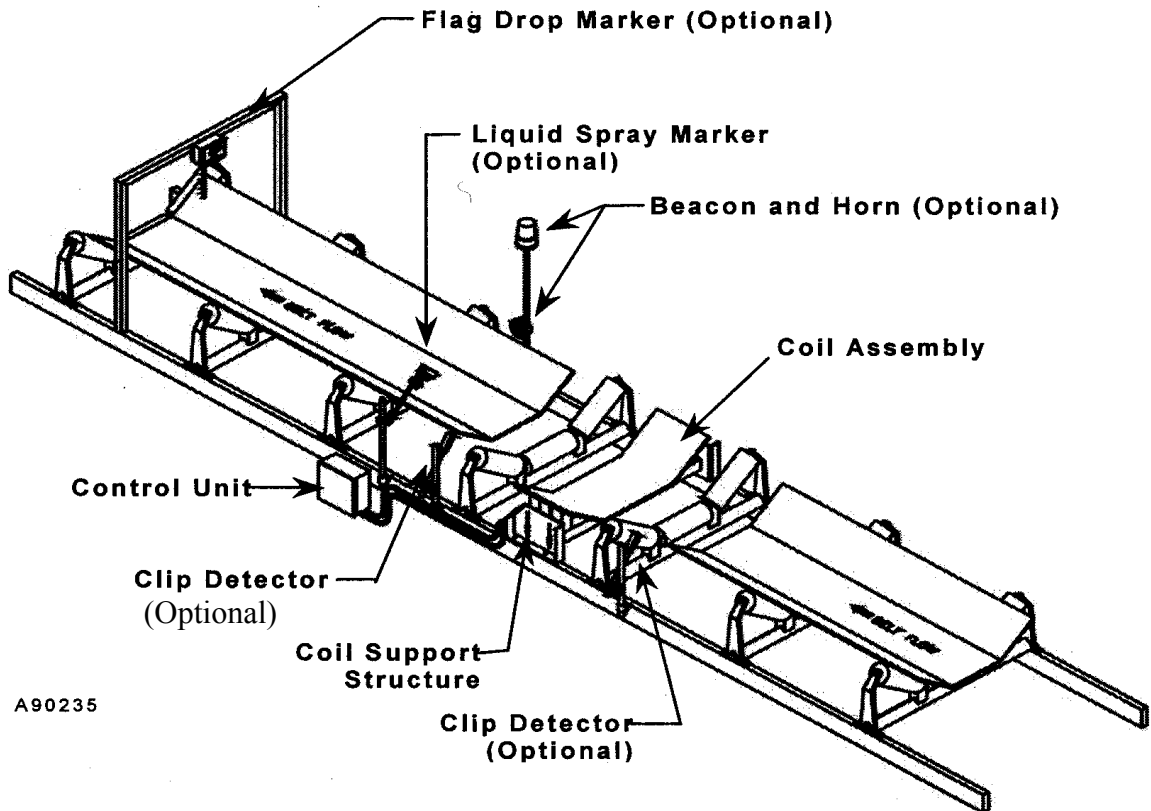

Figure 1-7. TMD System Components: Under Belt Single Coil

Support Structure & Coils

The coils (or coil) are mounted on a rugged support structure made of non-conducting fiberglass material. On a dual coil TMD, the transmitter coil is swing-mounted above the belt to protect the coil and support from being damaged by oversized material. The receiver coil is mounted under the belt.

On an under belt single coil TMD, the transmitter and receiver coils are together in a coil assembly mounted under the belt. The coil support structure does not extend above belt height (see Figure 1-7).

Coils are made of impact-resistant polyvinyl chloride (PVC) and are designed to withstand stresses up to 10 times gravity.

The transmitter coil transmits the pulsed electrical energy to the conveyor burden. The receiver coil receives the electrical energy signal from the conveyor burden. Within this signal is the eddy current when tramp metal is present.

Control Unit

The Oretronic III control unit is a microprocessor-based instrument that provides excitation for the transmitter coil, accepts receiver coil signals, and annunciates the presence of tramp metal. The digital circuitry is housed in a NEMA 4X enclosure.

The front panel of the control unit provides the operator interface to the TMD system. It uses lighted displays and touch panel keys, simplifying calibration and operations.

Figure 1-8 shows the Oretronic III control unit enclosure.



Figure 1–8. Oretronic III Control Unit

Features and Options

The Oretronic III TMD includes a number of standard features and available options that enhance its performance in a conveyor system.

Simplified Operator Interface

The operator interface to the TMD is a front panel on the control unit. The front panel is composed of a touch panel keypad, LED indicators, an eight-character alphanumeric display, and a three-digit counter LED.

The touch panel makes it easy to enter and change values and to scroll the displays. The displays indicate tramp count and coast count during normal operations and are used during setup and calibration. LEDs visible from outside the enclosure indicate NORMAL, BYPASS, and ALARM conditions and a bar graph displays signal strength.

Optional high visibility indicators may be used to indicate NORMAL, BYPASS, and ALARM. This option is a light bar with bright incandescent lights that can be wired directly into the control electronics.

Remote Front Panel

A remote front panel display option using RS-485 serial communications can be added to the main TMD control unit. Remote display includes a separate power supply and has a distance limitation of 4,000 ft (1,219 m). Refer to Appendix B for more information about the remote front panel option.

Synchronization of Transmitter Pulses

When two or more detectors are within 30 feet of each other, the SYNC input feature allows for the synchronization of transmitter pulses. This prevents the detectors from mistaking a transmitter pulse from another detector for a metal signal.

To set up synchronization, one TMD is the “master” and the other are “slaves.” The master does not have SYNC input turned on; only the slaves have it on. SYNC OUT transmit on the master is connected to SYNC IN receive on the slaves. The master only transmits; it does not receive. The slaves only receive; they do not transmit.

Speed Sensor

An optional belt speed sensor can be added for optimal performance with variable speed belts. Speed input provides for accurate belt coast determination and other speed-dependent operations. The speed sensor output must not exceed 2 KHz.

Clip Detector

An optional belt clip detector is used with conveyor belts having metallic splices or repair clips. The detector momentarily reduces the sensitivity of the TMD while metal fasteners traverse the detection zone. Larger tramp metal will still be detected. Two clip detectors can be used on variable speed belts.

High Pile Detector

The optional high pile detector is designed to help protect the transmitter coil from damage caused by oversized material on the belt. If the transmitter coil swings away from the support structure because of impact, the display will show hi pile. If the transmitter coil does not swing back into position in four seconds, the alarm relays of the control are activated.

The high pile detector is available on a dual coil TMD only. The under belt single coil model does not have this feature because the transmitter coil is under the belt.

Timed Delay Marker

If an optional liquid spray or flag drop marker is used to visually identify the location of tramp metal on the conveyor, you can specify a timed delay that indicates to the TMD how long it takes for the detected tramp to move from the coils to the marking device. This helps ensure that the correct area of the burden is marked.

System Requirements

System requirements for incorporating a dual coil Oretronic III TMD into a conveyor system can be found on the following Engineering Drawings in Appendix C of this manual:

- Final Assembly, Standard System (D07328C-A001)
- Installation Placement, Standard System (D07328C-A002)

System requirements for incorporating an under belt single coil Oretronic III TMD into a conveyor system can be found on the following Engineering Drawings in Appendix D of this manual:

- Under Belt Single Coil Final Assembly (D07328C-A101)
- Under Belt Single Coil Installation Placement (D07328C-A102)

Technical Specifications

This section lists the technical specifications for the Oretronic III Tramp Metal Detector. Specifications apply to both dual coil and under belt single coil models unless otherwise noted.

Belt Speed

5–1,200 ft/min (1–366 m/min)

Construction (Coils and Support Assembly)

FRP reinforced support assembly Coils sealed in PVC

Size - Dual Coil Model (typical for 42-in belt width)

Support Frame:

54 in. x 39.75 in. x 24 in. (H X W X D)
(1,371.6 mm x 1009.6 mm x 609.6 mm)

Transmitter Coil, Flat:

43 in. x 9 in. x 0.75 in. (L x W x D)
(1,092.2 mm x 228.6 mm x 19.0 mm)

Receiver Coil, Flat:

43 in. x 15.5 in. x 0.75 in. (L x W x D)
(1,092.2 mm x 393.7 mm x 19.0 mm)

Size -Under Belt Single Coil Model (typical for 42-in belt width)

Support Frame:

18.1 in. x 39.75 in. x 24 in. (H x W x D)
(459.7 mm x 1,009.6 mm x 609.6 mm)

Coil:

44 in. x 18.5 in. x 0.75 in. (L x W x D)
(1,117.6 mm x 469.9 mm x 19.0 mm)

Weight (typical for 42-in belt width)

Coils and support assembly, dual coil model, approximately 135 lb (61 kg)

Coils and support assembly, under belt single coil, approximately 80 lb (36 kg)

Enclosure (Control Unit)

Type:

NEMA 4X, non-metallic

Size:

15.25 in. x 13.25 in. x 7.39 in. (H x W x D)
(381 mm x 336 mm x 188 mm)

Weight:

22 lb (10 kg)

Maximum Distance from Coils:

10 ft (3 m)

50 ft (15 m) with optional junction box

Environmental Conditions

Location:

Indoor/outdoor

Storage Temperature:

-67° to 158° F (-55° to 70° C) ambient

Operating Temperature:

-40° to 122° F (-40° to 50° C)

Humidity:

10 to 95% relative humidity, non-condensing

Altitude:

6,561 ft (2000 m)

Pollution Degree:

Pollution Degree 2

Power Requirements

Nominal Line Voltage:

115/230 VAC, selectable

Operating Range:

+10, -15%

Nominal Frequency:

50/60 Hz

Operating Range:

48/62 Hz

Fusing:

L1 side of line

 $\frac{1}{4}$ x 1 $\frac{1}{4}$

115 VAC (F1) - 3/8 A, 250 VAC, SB, "Type T"

230 VAC (F1) - 3/16 A, 250 VAC, SB, "Type T"

Maximum Non-Destructive Input Voltage:

150/275 VAC for one minute

Overvoltage Category:

Transient overvoltage according to installation category
(Overvoltage Category II)

Power Switch:

On circuit board

Displays/Keypad

Display:

Three seven-segment LEDs for counts
One eight-character alphanumeric LED display

Remote Display:

Option allows a second display and keypad to be remotely mounted

Bar Graph:

20 LED bars

Status LEDs:

Red for ALARM, green for NORMAL, yellow for BYPASS

Calibrate LED:

Indicates the detector is in calibrate mode

Keypad:

Mounted on the enclosure door
Cutouts for viewing display, status LEDs, and bar graph

Inputs

All isolated inputs have same commons connected to isolated supply voltage common with the exception of the receiver coil.

Clip Detector:

Isolated, supply voltage provided
Configured for two clip detectors on same input
24 V open circuit, 7 mA short circuit, and 3 mA threshold

Reset Disable:

Isolated, supply voltage provided
24 V open circuit, 7 mA short circuit, and 3 mA threshold

High Pile (dual coil only):

Isolated, supply voltage provided
24 V open circuit, 7 mA short circuit, 3 mA threshold

Speed:

Isolated

Frequency range: 0.25–2,000 Hz (0.2 ms min. pulse width)
 0.25–30 Hz (15 ms min. pulse width)

Thresholds: 1.0 V min./3.0 V max.

Hysteresis: 0.6 V min.

Input impedance: 10 K Ω typical, 500 Ω max.

Input current: –1 mA nominal

Max. non-destructive

Input voltage: \pm 50 V peak, continuous

SYNC In:

RS-485 receiver

Receiver Coil:

10 ft (3 m) maximum distance

 \pm 1 V max.**Remote Reset:**

Isolated, supply voltage provided

24 V open circuit, 7 mA short circuit, and 3 mA threshold

Isolated Supply:

24 VDC, 150 mA

Outputs

Alarm Relay:

One NO and one NC contact

Dry contact; 5 A, 250 VAC

Fail-safe

Bypass switch provided

Time Delay Relay:

Dry contact; 5 A, 250 VAC

Duration selectable in 0.1-second increments, 0.1–0.9 seconds

Delay adjustable in 0.1-second increments, 0.1–9.9 seconds

SYNC Out:

RS-485 driver

Transmitter Coil:

10 ft (3 m) maximum distance

Alarm Indicator:

Dry contact; 5 A, 250 VAC

Normal Indicator:

Dry contact; 5 A, 250 VAC

Note: The ALARM and NORMAL indicators are always in opposite states; they are opposite contacts of the same Form C relay.

Bypass Indicator:

Dry contact; 5 A, 250 VAC

Power On Indicator:

Dry contact; 5 A, 250 VAC

Option:

Dry contact; 5 A, 250 VAC

Communications

One RS-485 port standard in every detector, 2 wire, or 4 wire selectable

Baud Rates:

600–19200 baud

Odd/Even/No parity

Isolation:

Yes

Function:

Communications or remote display

Chapter 2 Installing the TMD

This chapter provides information about installing and setting up the Oretronic III TMD. It discusses installation considerations, provides procedures for mounting, and wiring, describes the hardware configuration, and provides procedures for determining initial setup parameters for the device.

Overview

The customer is responsible for initial inspection of the equipment and for site preparation. It is essential that the equipment be placed on the production line in accordance with the guidelines set forth in this chapter.

The customer must ensure that qualified personnel are available to make interconnections with other production equipment and perform work at the installation site. A customer service representative is available to assist with installation and verify operation as well as train personnel assigned to operate and maintain the equipment.

Installation Considerations

Do not connect power to the machine or turn on the unit until you have read and understood this entire chapter. The precautions and procedures presented in this chapter must be followed carefully to prevent equipment damage and protect the operator from possible injury.



WARNING

Failure to follow safe installation and servicing procedures could result in death or serious injury.

- Make sure only qualified personnel perform installation and maintenance procedures in accordance with the instructions in this manual.
- Allow only qualified electricians to open and work in the electronics cabinets, power supply cabinets, control cabinets, or switch boxes.

Mounting Location

The coil support structure and coil(s) must be mounted properly for the TMD to function correctly. Large metallic objects near the coil(s) will cause a reduction in signal strength. To prevent loss in signal strength, make sure that no metallic objects such as steel girders, deck plates, skirt boards, return idlers, or metal building walls are within 4 ft (1.2 m) of the receiver coil. (Carry idlers and conveyor stringers may be within this distance.)

Other considerations for mounting the support structure and coil(s) include: The coil support structure must be located so that the conveyor will stop before tramp is discharged.

- Metal deck plates or skirt boards located within 4 ft (1.2 m) either side of the coil support structure must be removed or replaced with non-metallic parts.
- Metal chutes of feed points should be at least 8 ft (2.4 m) away from the coil support structure.
- Magnets must be at least 18 ft (5.5 m) away from the coil support structure.
- Corrugated metal covers located within 4 ft (1.2 m) either side of the coil support structure must be removed or replaced with non-metallic covers.

The control unit enclosure should be mounted in a vibration-free area less than 10 ft (3 m) from the coil(s) and should be protected from excessive heat, cold, or moisture.

See the Final Assembly drawings and the Installation Placement drawings in Appendix D of this manual for additional installation considerations.

Electrical Specifications

- 115/230 VAC, +10%, -15%
- 50/60 Hz
- Single phase, 30 VA, 0.25 A

Input Power Requirements

- Switch selectable: 115 VAC or 230 VAC
- Fusing: 115 VAC (F1) - 3/8 A, 250 VAC, SB, "Type T"
230 VAC (F1) - 3/16 A, 250 VAC, SB, "Type T"

Safety Precautions



WARNING

High voltage that may be present on leads could cause electrical shock.

- Disconnect incoming power at mains before beginning any installation or wiring procedures.
- Use extreme caution when testing in, on, or around the electronics, PC boards, or modules. There are voltages in excess of 115 V or 230 V in these areas.
- Covers over the electronics should always remain in place during operation. Remove only for maintenance procedures with the machine's power OFF. Replace all covers before resuming operation.



WARNING

Use only the procedures and new parts specifically referenced in this manual to ensure specification performance and certification compliance. Unauthorized procedures or parts can render the instrument dangerous to life, limb, or property.



WARNING

All wiring must be done in accordance with field wiring diagrams, applicable sections of the National Electrical Code, and local electrical codes.



WARNING

Keep hands and clothing away from all moving or rotating parts.



WARNING

This equipment should not be operated at more than the production rate stated on your Equipment Specification sheet or used in applications other than those stated in the original order.

Equipment Handling

The TMD coil support structure and coil(s) are normally packaged on a wooden skid and may be lifted with a forklift or crane. Do not lift the equipment using the support structure; use the exterior wooden structure. Use care when lifting this equipment to avoid damage to the coil(s).

The TMD control unit is normally packaged sealed in foam, which is then placed in a cardboard carton. This carton should be handled manually. Lift the carton observing the “This Side Up” labels. Do not use hooks. Use extreme caution when handling this equipment because the electronics are extremely delicate.

Inspection and Unpacking

The Tramp Metal Detector has been properly packaged for shipment. Inspect all packages before opening. If there is any evidence of shipping damage, notify the shipping carrier immediately; the carrier may be responsible for the damage.

After unpacking, inspect the unit for broken or damaged components.

Inspection and Unpacking

The Tramp Metal Detector and associated equipment can be safely stored, with the cover secured and hole plugs installed, in ambient temperatures between -67 and $158 \times F$ (-55 to $70 \times C$). The control unit should be protected against moisture.

Installing the TMD

This section provides procedures for installing the coil support structure and coils and for mounting and wiring the control unit. The installation procedures are different for dual coil and under belt single coil TMDs.

Installing the Coil Support Structure and Coils for a Dual Coil TMD

The coil support structure is shipped from the factory partially assembled. Coils are mounted on the cross members. Refer to Outline, Mounting and Assembly, Coil Stand (D07328C-A003) for assembly information. Refer to Installation Placement (D07328C-A002) for detailed information about positioning the system components.

Note: The coil support structure must be located so that the conveyor will stop before any tramp is discharged. Use the following procedure to assemble and install the coil support structure and coils on your conveyor.

1. Assemble the coil support structure and the coils so that all electrical cables for the transmitter and receiver coils are on the same side of the conveyor.
2. Mount the transmitter coil to allow it to swing in the direction of belt travel at a height above the belt so it will clear normal conveyor loads.
3. The swing arm feature allows high loads to pass without damage. If the transmitter coil is mounted too high, the system's sensitivity is reduced.
4. Set the receiver coil located under the belt 1–2 in. (25.4–50.8 mm) below the belt line. The belt must not rub on the receiver coil.
5. Mount the coils across the conveyor on the centerline between the two idlers.
6. Idler spacing at the coil location must be greater than 4 ft (1.2 m). If for mechanical reasons this spacing is not possible, the distance may be reduced by using rubber impact-type idlers.
7. Remove all deck plates, cross bracing, and return idlers located within 4 ft (1.2 m) of the receiver coil.

Installing the Coil Support Structure and Coil for an Under Belt Single Coil TMD

The coil support structure is shipped from the factory partially assembled. The coil is mounted on the cross members. Refer to Under Belt Single Coil Outline and Mounting (D07328C-B101), Under Belt Single Coil, Assembly Stand, (D07328C-A110) for assembly information. Refer to Under Belt Single Coil Installation Placement (D07328C-A102) for detailed information about positioning system components correctly.

Note: The coil support structure must be located so that the conveyor will stop before any tramp is discharged. Use the following procedure to assemble and install the coil support structure and coil on your conveyor:

Assemble the coil support structure.

Set the coil under the belt 1–2 in. (25.4–50.8 mm) below the belt line. The belt must not rub on the coil.

Mount the coil across the conveyor on the centerline between the two idlers.

Idler spacing at the coil location must be greater than 4 ft (1.2 m). If for mechanical reasons this spacing is not possible, the distance may be reduced by using rubber impact-type idlers.

Remove any deck plates, cross bracing, and return idlers located within 4 ft (1.2m) of the coil.

Installing System Devices

Optional system devices such as clip or high pile detectors, spray, or flag drop markers, and alarm beacons or horns may need to be assembled and installed on your conveyor.

Refer to the appropriate drawings in Appendix D for information about installing optional system devices for your TMD model. The Installation Placement drawings and Final Assembly drawings show where optional devices are to be placed on your conveyor.

Mounting the Control Unit

The control unit should be mounted in a vibration-free area less than 10 ft (3 m) from the coils. Mount the control unit enclosure to a rigid, flat, vertical surface using the 2-position mounting feet on the back of the enclosure (see figure 2-1)

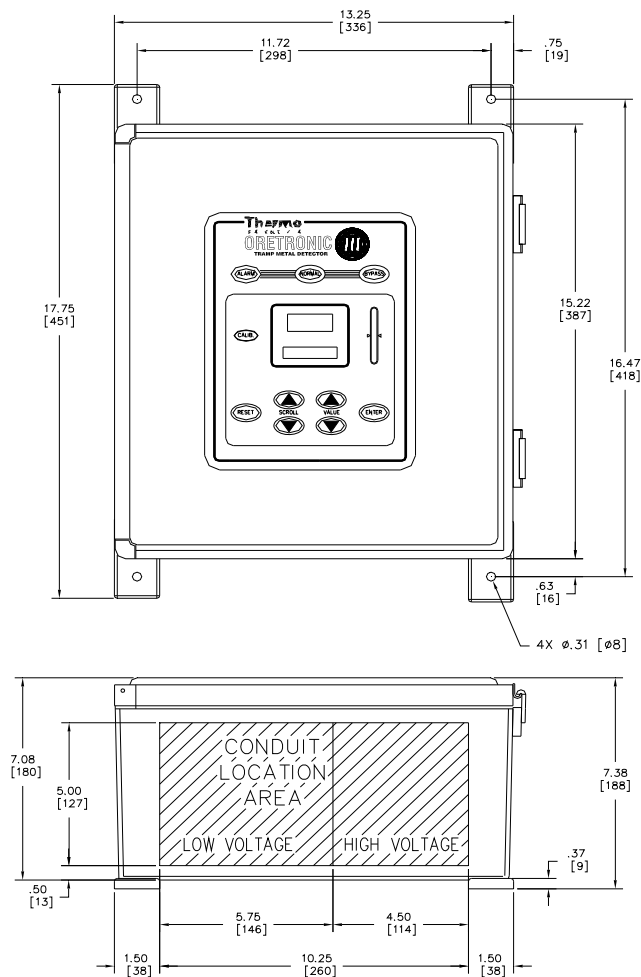

Figure 2-1. Control Unit Mounting Dimensions



WARNING

Make sure the mounting surface is flat so that the fiberglass enclosure does not twist or warp when the mounting bolts are tightened.

Follow this procedure to mount the control unit enclosure.

1. Open the enclosure door.
2. Remove the power cover to allow access to the line power terminals.
3. Bolt the enclosure to a flat, vertical surface using the 2-position mounting feet on the back of the enclosure (see Figure 2-1).
4. Punch the required conduit holes in the bottom of the enclosure for the power supply cable, coil cables, control wiring, communications cable(s), and any additional signal wires and conduit.
5. Locate the holes in the appropriate areas of the enclosure to separate high (greater than 30 V) and low (less than 30 V) voltages (see Figure 2-2).
6. Install conduit.

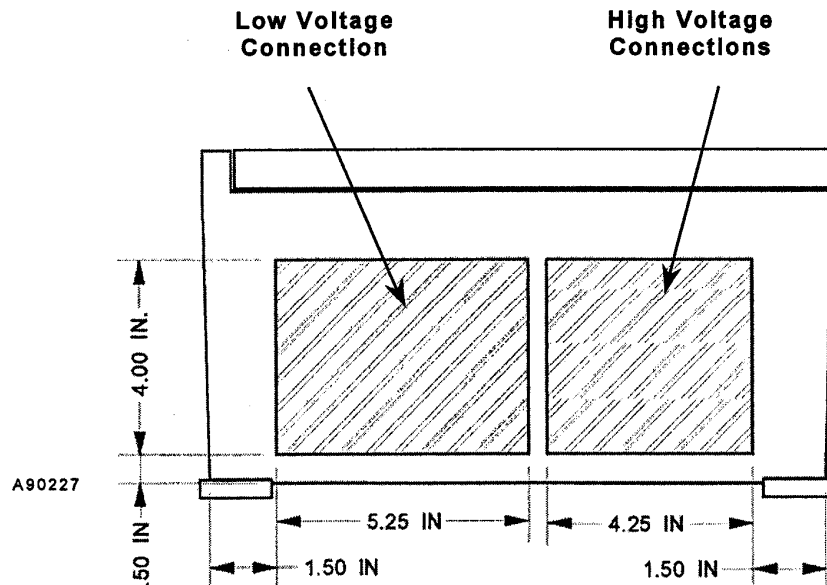

Figure 2-2. Control Unit Enclosure - Bottom View

Field Wiring the TMD

All wiring, except as noted, is the responsibility of the customer. Follow the field wiring diagram for your system or refer to the Field Wiring Diagram (D07328C-E201) in Appendix D to connect system wiring to the CPU board in the control unit.



WARNING

All wiring must be done in accordance with field wiring diagrams, the National Electrical Code, and all local electrical codes.

Do not route coil cables through the same conduit with power cables or any large source of electrical noise.

Critical Wiring Conditions

Be sure to observe the following critical wiring conditions to ensure proper connection of your detector:

- Ensure main power is OFF.
- High voltage (>30 V) and low voltage (< 30 V) cables must be routed through different areas of the control unit enclosure (see Figure 2-2).
- Earth ground all enclosures and conduit. A ground connection between all conduits is required.
- Stranded, rather than solid, wire should be used. This wiring should be long enough, and routed, to allow the chassis to be removed from the front for servicing.
- Connect the shields only where shown.
- Never use a “megger” to check the wiring.
- A readily accessible disconnect device (maximum 20 A) shall be incorporated in the field wiring. This disconnect should be in easy reach of the operator and it must be marked as the disconnecting device for the equipment.
- All conduit should enter the bottom of the enclosure. Do not run conduit through the top or sides of the enclosure.

Field Wiring Procedure Follow all cable number specifications on the Field Wiring Diagram (D07328C-E201) when connecting wiring to the CPU board. Figure 2-3 shows the locations of the terminal blocks.

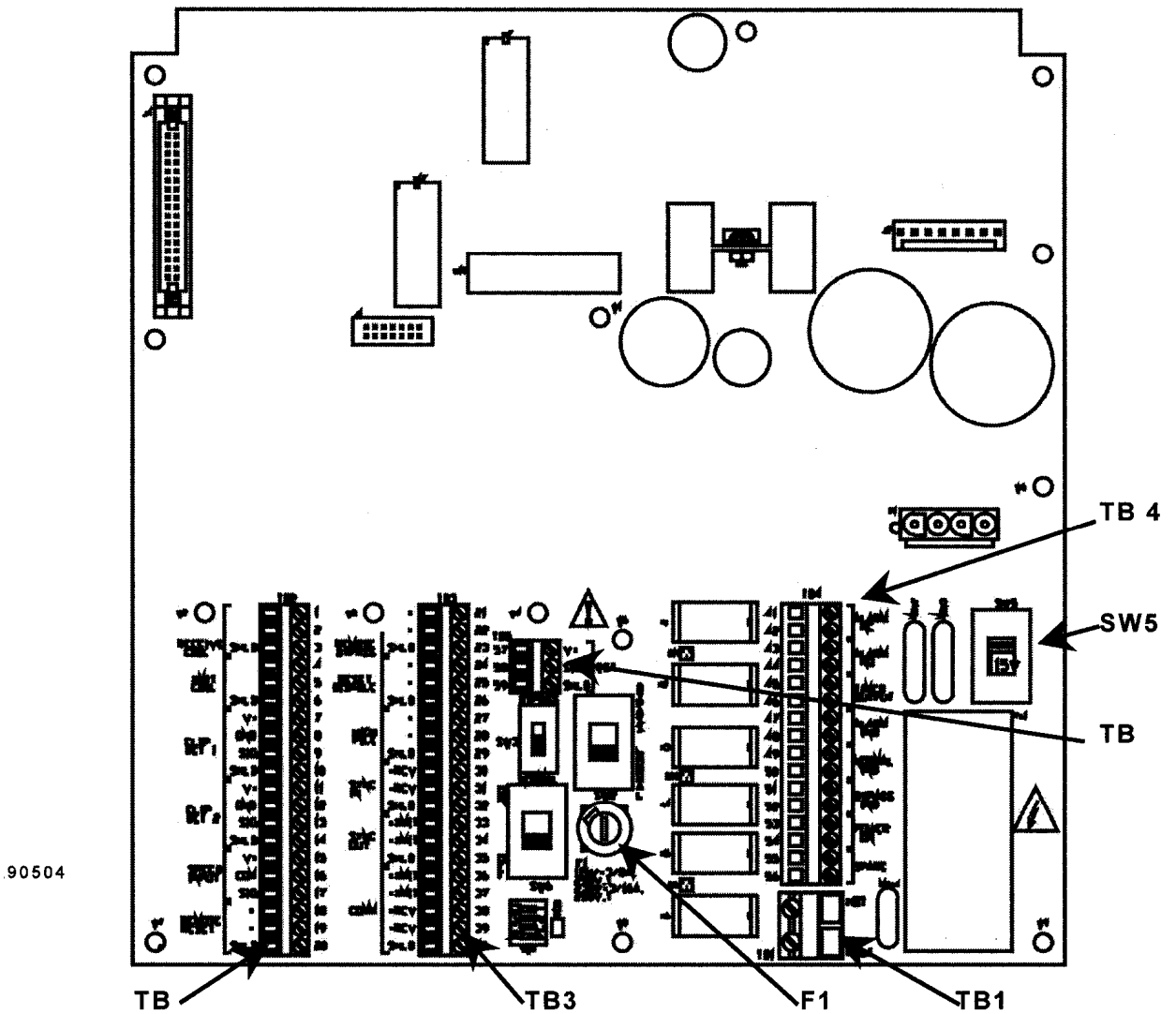

Figure 2-3. Terminal Block Locations on the CPU Board

Use this procedure to wire the control unit.

1. Route incoming connections at line voltages above 30 V through a conduit hole in the bottom right of the enclosure so that they are protected by the power cover (see Figure 2-2).

Leave enough loose wiring (about 8 in.) to allow the board to be moved without having to disconnect wires. Connect all alarm and indicator output wiring to the appropriate terminals on TB4.

2. Connect all alarm and indicator output wiring to the appropriate terminals on TB4.
3. Route incoming connections at voltages below 30 V through a conduit hole on the bottom left of the enclosure (see Figure 2-2).
4. Connect all coil cables, detector wiring, control wiring, and communications cables to the appropriate terminals on TB2 and TB3 (see Figure 2-3).

Connecting Incoming Power



WARNING

Do not apply power until you have read and understood this entire section. Improper connection may result in damage to your detector.

- Verify that the input voltage is correct with a voltmeter before you connect it to the unit. The red tag attached to the machine specifies the correct input voltage for your particular unit.
- Earth ground must be provided to the unit. Do not use conduit to provide this ground.
- Follow your local electrical codes and regulations for minimum wire size and routing.

Follow this procedure to connect incoming power to the control unit. See Figure 2-3 for the locations of the terminals.

1. Determine the input power to be supplied to the control unit and set SW5 to the correct voltage (see Figure 2-3).
2. Verify that fuse F1 on the CPU board is correct for the input power.
115 VAC = 3/8 A, 250 VAC, SB, “Type T”
230 VAC = 3/16 A, 250 VAC, SB, “Type T”

3. Route incoming power wiring through a conduit hole on the bottom right of the enclosure
Use 14 AWG stranded copper wire.
Maintain a gap of at least ½ in. from low voltage wires.
Leave enough loose wiring to allow the board to be moved without having to disconnect wires. (Generally, 8 in. is sufficient.)
4. Connect the GROUND wire to the safety ground terminal located on the right inside of the chassis.
5. Wire the HOT input power to the TB1 terminal labeled “HOT.”
6. Wire the NEUTRAL input power to the TB1 terminal labeled “NEUT.”
7. Replace the power cover.

Note: Make sure the chassis cover is closed before applying power.

Configuring the TMD

This section describes the switches that can be set in the field to adapt the TMD to your environment. SW1 DIP Switches are located on the display board, which is on the back of the control unit enclosure door. SW2–SW6 are located on the CPU board.

DIP Switch Settings

SW1 DIP Switches (on the display board) are used to set the detector hardware configuration. Switches for enabling password protection software, speed sensor input, SYNC input, belt direction, measure units, and cold start are set at the hardware level because these parameters are generally set once and not changed.

The settings of these switches can be viewed on the TMD front panel after the system is operational. Refer to Switch Setting.

Table 2-1 describes the functions of the DIP Switch settings on SW1.

POS	FUNCTION	ON	OFF
1	Password protection	Enable password protection software.	Eliminate password.
2	Speed sensor input	Enable speed sensor input option.	Speed sensor disabled.
3	SYNC input	Enable SYNC input on the slaves for synchronization of transmitter pulses. (Required when two detectors are within 30 ft of each other.)	SYNC input disabled. (Required setting on the master.)
4	Belt direction	Reversed	Normal
5	Factory test		Normal operation. (Required setting.)
6	Units selection	Metric	English
7	F5	Enable F5 error alarm	Disables F5
8	Cold start	Enable cold start on power up.	Cold start disabled.

Table 2-1. SW1 DIP Switch Settings

CPU Board Switch Settings

Four switches on the CPU board must be set for power, line voltage, and alarm output for the TMD. If RS-485 communication is supported, a fifth switch must also be set.

Figure 2-4 shows the locations of the switches on the CPU board.

Table 2-2 and Table 2-3 describe the functions of the switch settings.

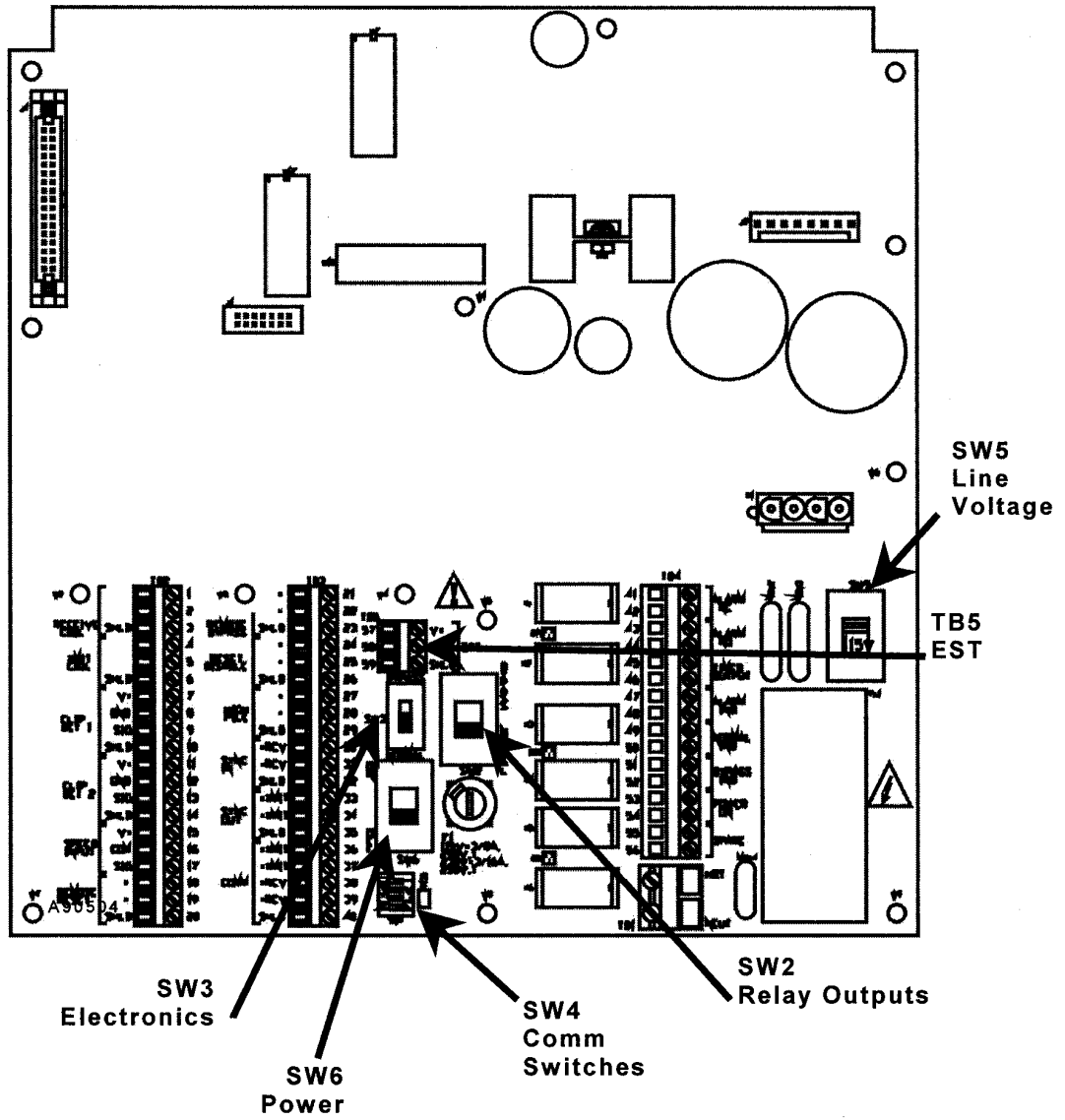

Figure 2-4. Switch Locations on the CPU Board

Note: Both switches SW2 (relay outputs) and SW3 (electronics) must be in the BYPASS position to disable alarms while setting up and calibrating the TMD. When the TMD is set up and operating properly, be sure to place **BOTH** these switches in the NORMAL position before running production.

SWITCH	FUNCTION	SETTINGS
SW2 & SW3	Enables or disables alarm output. To disable, both SW2 and SW3 have to be in bypass position.	NORMAL/BYPASS In NORMAL position, alarm output is enabled. If both SW2 and SW3 are in BYPASS position, alarm output is disabled and BYPASS indicator is ON.
SW4	Communication switches	See <i>Figure 2-3</i>
SW5	Sets power line voltage.	115/230 Factory set to 115 V
SW6	Turns power to the control unit on and off.	ON/OFF

Table 2–2. CPU Board Switch Settings

POS	FUNCTION	ON	OFF
1 & 2	Configures RS-485 communication.	2-wire RS-485	* 4-wire RS-485
3	Connects a termination resistor across the receive input.	* Termination ON	Termination OFF
4	Not used		

* Setting for TMD remote front panel.

Table 2–3. Comm Switch SW4 Settings

Initial Power On

After the TMD is wired and the hardware is configured, turn power on at the mains.

Calibrating the Speed Sensor

If your system uses a speed sensor, use this procedure to calibrate it. The procedure is written as though you are familiar with the operator interface to the Oretronic III TMD. If you are not familiar with the operator interface, please read the detailed descriptions of the front panel keys, indicators, and displays in Chapter 3 of this manual before beginning this procedure.

1. Run the conveyor belt at normal production speed.
2. Place the TMD in Setup mode.
3. Scroll to the BELT SPD display
The first (left most) digit in the counter will be flashing.
4. Press the up or down VALUE key until the correct digit of the belt speed is displayed
5. Press ENTER to set the digit.
6. The next digit in the counter will be flashing.
7. Repeat Steps 4 and 5 to enter each digit of the belt speed.

When the last digit is entered, the entire counter flashes indicating that calibration is in progress. The display reads CAL BELT.

When the speed calibration is complete, the counter stops flashing and the display rereads SPD DONE.

8. Scroll up to the BELT SPD display to verify that the calibration is correct.
9. Place the TMD in Run mode.

Determining Values to Use for Initial Setup

There are three system-dependent measurements you may need for the initial setup of the TMD. These measurements are:

- Belt speed (if you are not using a speed sensor)
- Clip delay (if you are using a clip detector)
- Timed delay (if you are using a marking device)

To take these measurements, you must first place a timing mark on the conveyor belt using the following procedure.



CAUTION

Keep hands and clothing away from all moving or rotating parts.

1. Empty the conveyor belt of all material.
2. Stop the conveyor belt.
3. Place a mark on the belt that will be visible while the belt is running.
4. Start the conveyor belt.

Determining Belt Speed

If your system does not use a speed sensor, you will need to know the belt speed in feet/minute. To determine belt speed:

1. Measure the length of the conveyor belt in feet.
2. Clock the time, in seconds that it takes for the conveyor belt to make one revolution.
3. Divide the length of the belt (in feet) by the revolution time (in seconds) and multiply by 60.

This value is the belt speed in feet/minute.

$(\text{Belt Length divided by Revolution Time}) \times 60 = \text{Belt Speed (ft/min)}$.

Determining Clip Delay

If your system uses a belt clip detector, you will need to know the distance between the clip detector and a point six inches past the receiver coil. This value is the clip delay. It is used to “desensitize” the TMD so that belt clips and splices can pass through the detector without tripping it.

To determine clip delay, measure the distance, in feet, from the clip detector to a point six inches past the receiver coil. Then determine the time it takes for the splice to travel this distance.

If a belt clip detector is not used, this value should be 0 in setup.

Determining Timed Delay

If your system uses a marking device, you will need to know how long it takes for tramp metal to move from the coils to the marking device. This value is the timed delay. It is used to allow enough time for detected tramp to get to the marking device so that the correct area is marked. The TMD can track up to 10 detections between the coils and the marking device.

To determine timed delay, clock the time, in seconds, that it takes for the mark on the belt to move from the receiver coil to the marking device. This value will be equal to:

Distance (ft) x (Belt Speed (ft/min) x 60)

Chapter 3 Operating the TMD

This chapter provides information about setting up and operating the Oretronic III TMD. The operator interface, including all keys, indicators, and displays, is described. Procedures for initial setup and calibration are provided.

Overview

You operate the Oretronic III TMD through the control unit. The control unit is mounted locally, but it may be operated either locally or remotely. Remote operation uses a second front panel, identical to the one on the control unit that is connected to the control unit. Operations are performed from the remote front panel.

You can optionally connect the control unit to a Modbus communications network to set up and operate the TMD. This method of remote control uses Modbus protocol for reading and writing detector registers.

The TMD is a dual-language instrument. All measure units can be either English units or Metric units, as selected by the SW1 DIP Switch. (This chapter uses English units.) If you change your units' selection after the TMD is set up and calibrated, you must redo the calibrations and setup using the new units; the TMD will not convert values.

Operator Interface

The operator interface to the TMD is a front panel on the control unit. The front panel is composed of a touch panel keypad, LED indicators, an eight character alphanumeric display, and a three-digit counter LED.

Figure shows the front panel.

Note: To simplify the descriptions in this section, the alphanumeric display will be called “the display” and the counter LED will be called “the counter.”

This section describes the components of the front panel and how they are used to set up the TMD.



Figure 3–1. Tramp Metal Detector Front Panel

Operating Modes

The TMD has two modes of operation: Run mode and Setup/Calibrate mode. When the TMD is in Run mode, the NORMAL LED is lit, the display shows the word COUNT, and the counter shows the total count of detected tramp.

If the TMD trips (detects tramp), the ALARM LED lights, the display shows what caused the trip (METAL or LONG BAR), and the counter shows the coast count, which is the number of pieces of tramp detected since the system tripped (or while the belt was “coasting” to a stop), if any.

When the TMD is in Run mode, you can display all setup and calibration variables but you cannot change them.

Setup/Calibrate mode allows you to make changes to the device setup and calibrate the TMD for specific metal. In Setup/Calibrate mode, both the BYPASS and CALIB LEDs are lit. The display indicates which variable is shown in the counter; the counter shows the current value of that variable.

Menu Structure

The operator interface is based on a menu structure that guides you through TMD setup and calibration. The menu structure has five “high-level” menus, shown in the eight-character alphanumeric display, that indicate the operating mode and status of the TMD.

Within the setup and calibrate high-level menus are the individual parameters and settings that define how your TMD is to operate. Figure shows the TMD menu tree.

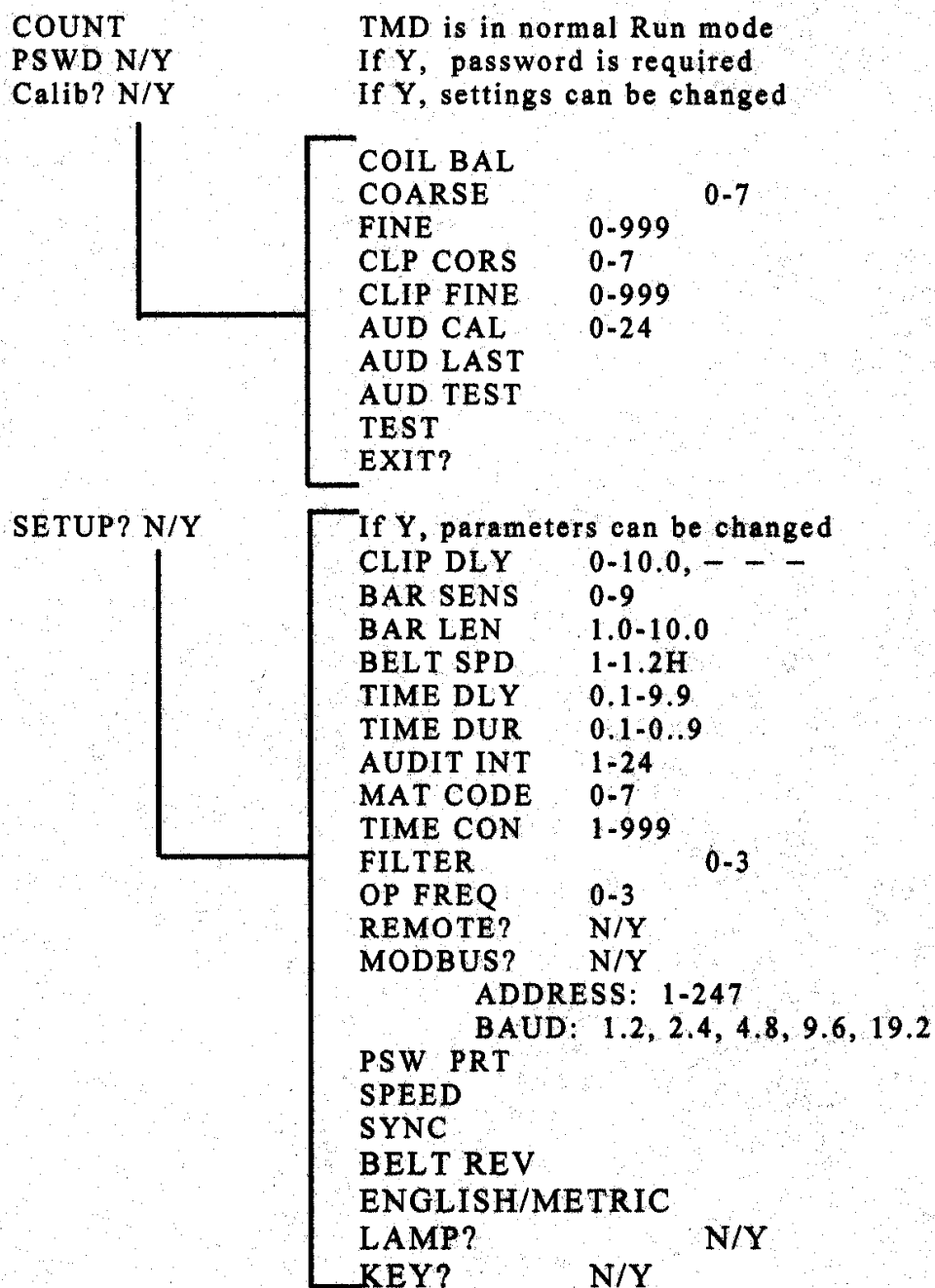

Figure 3-2. TMD Menu Tree

Front Panel Keypad

The keys on the TMD front panel are soft touch keys on a flat panel. The keys are used to set up and calibrate the TMD. Figure shows these keys on the front panel.

SCROLL Keys

The up and down SCROLL arrow keys move the scroll of display “screens” up or down one screen at a time when the TMD is in Setup/Calibrate mode.

In Run mode, the SCROLL keys scroll through the high-level menu displays shown below:

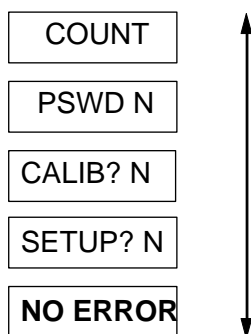

When either end of a scroll is reached, scrolling ends. Scrolls do not wrap.

VALUE Keys

The up and down VALUE arrow keys change the value of the displayed variable when the TMD is in Setup/Calibrate mode. Pressing the up arrow increases the value. Pressing the down arrow decreases the value. Values increase or decrease only within the range for the individual variable.

Changed values are not entered into memory until you press the ENTER key, and they flash in the counter until you press it.

Changed values are not permanently stored in system memory until the TMD is placed back into Run mode.

ENTER Key

The ENTER key enters a changed variable into memory. If the VALUE keys are used to change the displayed value but the ENTER key is not pressed, the original value of the variable is retained in memory.

The ENTER key is also used to clear error and fault messages (refer to Section “Error Messages”).

RESET Key The RESET key is used to reset the ALARM output after metal detection. It also resets the coast count to zero. Pressing this key returns the TMD to normal Run mode after an alarm.

Front Panel LED Indicators Four LED indicators on the TMD front panel provide information about the detector’s current operating status. Figure shows these indicators on the front panel.

NORMAL The NORMAL LED (green) indicates that the TMD is in normal Run mode, has not determined a fault or error exists, and has not detected metal since the RESET key was pressed. It is never on when the ALARM LED is on.

ALARM The ALARM LED (red) indicates that metal was detected and the TMD has not been reset since the detection. This LED will also be on if a fault or error is present. It is never on when the NORMAL LED is on.

BYPASS The BYPASS LED (yellow) indicates that the alarm output relay is disabled by the SW2/SW3 switch settings on the CPU board (see Section (“CPU Board Switch Settings”) or by remote bypass input.

Alarm output is also disabled (and the BYPASS LED lit) when the TMD is in Setup/Calibrate mode (CALIB. LED lit). This allows you to set up and calibrate the detector without generating alarms during the process.

BYPASS disables the alarm even if metal is detected and essentially isolates the TMD from the rest of the system. The detector itself will function normally otherwise.

CALIB The CALIB LED (red) indicates that the TMD is in Setup/Calibrate mode. When it is lit, you can change setup variables or calibrate the detector.

Bar Graph The bar graph is a vertical bank of 20 LEDs that indicates relative signal strength from tramp metal. The more LEDs that are lit from the bottom up, the stronger the signal. The bar graph is also used during coil balancing.

Note: At high belt speeds, the bar graph may not respond quickly enough to accurately indicate the signal strength of a metal trip.

Front Panel Displays

The front panel has two types of display indicators: an eight-character alphanumeric display and a three-digit counter LED. Figure shows these indicators.

The display shows the Run screen and the counter shows the total count when the TMD is in Run mode. Total count is the running total of detected tramp (or total trips). Total count cannot be reset. In Setup/Calibrate mode, the counter shows variable values.

When the display shows the Run screen and metal is detected, the counter shows the coast count. Coast count is the number of pieces of tramp detected since the TMD tripped (or while the belt was “coasting” to a stop). Pressing the RESET key sets the coast counter to zero.

If the display is anywhere else in the scroll, the counter shows the current value of the displayed variable.

- To access the variables, use the scroll keys to move the display up and down the scroll.
- Change variables by pressing the VALUE keys.
- You must press the ENTER key to apply a new value.
- When the value of a variable has been changed but not entered, the value of the variable flashes.

The remainder of this section describes the display screens in the order they appear in the scroll.

Run Screen

The first screen in the scroll is the Run screen. This is the screen you will see when the system powers up. The display shows COUNT and the counter shows the total count of detected tramp. The NORMAL LED is lit.

If the TMD has tripped, the NORMAL LED is off and the ALARM LED is lit. The counter shows the coast count, if any, of tramp metal detected since the trip. The display shows METAL if metal was detected. If the bar/rod detection option is active and a long bar or rod is detected, the display shows LONG BAR.

Pressing the RESET key resets the coast counter to zero, returns the display to the total count display, and returns the TMD to Run mode (NORMAL LED is lit).

Password Protection Screen

Password protection is used to restrict access to the setup and calibration settings. The SW1 DIP Switch on the display board enables or disables the password protection software (refer to Section “DIP Switch Settings”). If the TMD is password protected, settings may be viewed but not changed.

If the switch is set to enable password but no password has been defined, the display will show PSWD N when you SCROLL down from the Run screen. If you do not define a password, protection is not enabled and the system will go to the calibration screens when you SCROLL down again.

Follow this procedure to define a password. The procedure begins at the PSWD N display.

1. Press a value key then press ENTER.
The display changes from PSWD N to PSWD Y indicating that you want password protection. The Y will be flashing.
2. Press ENTER
3. Press the SCROLL down key.
The display changes to PSWD=. The counter shows 000 and the first digit will be flashing.
4. Press the VALUE keys to scroll through the range 0–9.
5. When the digit you want is showing, press ENTER.
The next digit in the counter will be flashing.
6. Repeat the process of scrolling the counter and entering the digit until your password is defined.
The range for each of the three digits in the password is 0–9, so your password can be from 000 to 999.
7. To activate the password, put the TMD into Run mode and wait at the Run screen for 30 seconds.

If password protection is active, the display will show PSWD= when you SCROLL down from the Run screen. If you want to make any changes to calibration settings, you must enter the password. The display changes to PSWD Y and you can proceed to the calibration

screens. If you just want to view the current settings, SCROLL down when PSWD= is displayed.

To disable password protection, use the value keys to change PSWD Y to PSWD N.

Note: To remove a forgotten password, set the SW1 DIP Switch to OFF and cycle the power. Set the DIP Switch back to ON and use the procedure above to define a new password.

Calibration Screens

These display screens are used to calibrate the TMD. The values of these variables determine how sensitive the TMD should be for your application.

The first calibration screen enables or disables changes to calibration settings. When you SCROLL to the screen, the display shows CALIB? N. To change calibration settings, press the down VALUE key to change the display to CALIB? Y then press ENTER. This puts the TMD into Calibrate mode.

Leaving the display on CALIB? N and pressing ENTER allows you to scroll through the calibration screens and view all settings but not change them.

To return the TMD to normal Run mode after making changes or viewing settings, SCROLL up to the RUN screen or SCROLL down to the EXIT? screen and press ENTER.

Coil Balance

This screen shows coil balance, which is an indication of how well the generating and receiving coils are aligned. The screen is for viewing only; you cannot make changes to it. The display shows COIL BAL. The counter indicates how much of the range of the electronic balance is being used from 0 to 999.

The current balance condition is indicated on the bar graph, with the middle LED in the bar being the zero point. If no LEDs are lit, the coils are balanced well. The more LEDs that are lit up or down from the middle the more out-of-balance the coils are in the corresponding direction.

You can “quick balance” the coil electronically by pressing the ENTER key. The display flashes QUIK BAL, then returns to COIL BAL.

Calibrate for Metal

The next two screens are used to calibrate the sensitivity of the TMD for detecting tramp metal. The first screen adjusts the coarse sensitivity of the tramp signal. The second screen adjusts the fine sensitivity.

When you SCROLL to the first metal calibration screen, the display shows COARSE. The counter shows the current coarse sensitivity setting, between 0 and 7.

You can change the coarse sensitivity setting manually using the VALUE keys and the ENTER key.

You can start auto-calibration by pressing the ENTER key without changing the value. The counter then shows A0 and the display flashes AUTO MET. When the calibration is complete, press ENTER again. The display flashes QUIK BAL while the system rebalances, and then returns to the COARSE display. The counter shows the new coarse metal setting.

When you SCROLL to the second metal calibration screen, the display shows FINE. The counter shows the current fine sensitivity setting, between 0 and 999.

You can change the fine sensitivity setting manually using the VALUE keys and the ENTER key.

You can start auto-calibration by pressing the ENTER key without changing the value. The counter then shows A1 and the display flashes AUTO MET. When the calibration is complete, press ENTER again. The display shows MET DONE. The counter shows the new fine metal setting.

To abort the auto-calibration, SCROLL up or down to terminate without changing the previous setting.

Calibrate for Clip

The next two screens are used to calibrate the sensitivity of the TMD for detecting belt splice clips. The first screen adjusts the coarse sensitivity of the clip signal. The second screen adjusts the fine sensitivity.

When you SCROLL to the first clip calibration screen, the display shows CLP CORS. The counter shows the current coarse sensitivity setting, between 0 and 7.

You can change the coarse clip sensitivity setting manually using the VALUE keys and the ENTER key.

You can start auto-calibration by pressing the ENTER key without changing the value. The counter then shows A2 and the display flashes AUTO CLP. When the calibration is complete, press ENTER again. The display flashes QUIK BAL while the system rebalances, and then returns to the CLP CORS display. The counter shows the new coarse clip setting.

When you SCROLL to the second clip calibration screen, the display shows CLP FINE. The counter shows the current fine sensitivity setting, between 0 and 999.

You can change the fine clip sensitivity setting manually using the VALUE keys and the ENTER key.

You can start auto-calibration by pressing the ENTER key without changing the value. The counter then shows A3 and the display flashes AUTO CLP. When the calibration is complete, press ENTER again. The display shows CLP DONE. The counter shows the new fine clip setting.

To abort the auto-calibration, SCROLL up or down to terminate without changing the previous setting.

EST Cal The next three screens are used to calibrate and test Electronically Simulated Tramp (EST). EST is an optional system for your TMD. (Refer to Appendix C for complete installation, setup, and calibration of EST).

The EST LAST screen allows you to see the reading from the last time EST ran. The EST TEST screen allows you to test EST to ensure it is working properly.

Test This screen allows you to test your setup and calibration settings before returning to normal Run mode.

When TEST is displayed, you can pass your test piece of tramp metal to test your calibration without actuating the alarm relay outputs. The TMD will otherwise operate normally; the ALARM LED will light, and pressing RESET will reset ALARM and zero the counter.

Exit This screen allows you to exit the calibration screens and return to Run mode without having to SCROLL back up to the Run screen. The display shows EXIT?. To exit, press ENTER.

Setup Screens These display screens are used to set up TMD operating parameters and options. The values of these variables determine how the TMD will function in your application environment.

The first setup screen enables or disables changes to setup parameters. When you SCROLL to the screen, the display shows SETUP? N. To change setup parameters, press the down VALUE key to change the display to SETUP? Y then press ENTER. This puts the TMD into Setup mode.

Leaving the display on SETUP? N and pressing ENTER allows you to scroll through the setup screens and view all settings but not change them.

To return the TMD to normal Run mode after making changes or viewing settings, SCROLL up to the Run screen or SCROLL down to the EXIT? screen and press ENTER.

Clip Delay This screen is used to set the length of belt to let pass the detection area so a clip does not trip the TMD. The display shows CLIP DLY. The counter shows the length in feet from 0 to 30.0.

If the clip delay value is 0, clip detection is disabled.

Settings above 10.0 are a clip delay value — — —, used with variable speed belts where Clip Detector A input turns on the clip detector and stays on until Clip Detector B input turns it off.

Bar/Rod Sensitivity This screen is used to set the sensitivity of the TMD to long bars or rods. The display shows BAR SENS the counter shows the current sensitivity setting from 0 to 9. The larger the number, the more sensitive.

If the setting is 0, the bar/rod option is disabled.

Unlike calibrating for tramp metal and belt clips, calibrating for bar/rod detection is not automatic. You need to set and adjust the sensitivity manually. For information about setting bar/rod sensitivity correctly,

refer to Section 4.4.4 Adjusting for Bar/Rod Detection and Section 4.6 Passing Bars or Rods Undetected.

- Bar/Rod Length** This screen is used to set the maximum length of the bar or rod for the TMD to detect. The display shows BAR LEN. The counter shows the length in feet from 1.0 to 10.0.
- Belt Speed** This screen has two functions depending on the device configuration. A DIP Switch setting on the display board specifies whether a speed sensor is used (refer to Section “DIP Switch Settings”).
- If speed sensor input is disabled, this screen is used to set the belt speed in feet/minute. If speed sensor input is enabled, this screen shows the actual belt speed. The display shows BELT SPD. The counter shows the value from 1 to 1,200 feet/minute.
- If the belt speed is greater than 999 feet/minute, it will be shown in thousand feet/minute with a decimal point and an “H” following the number. For example, 1.1H is 1,100 feet/minute.
- Timed Delay** This screen is used to set the delay after detection for the timed marking output. The display shows TIME DLY. The counter shows the timed delay in seconds from 0.1 to 9.9. The timed output has a queue of 10.
- Timed Duration** This screen is used to set the duration of the timed marking output. The display shows TIMED DUR. The counter shows the timed duration in tenths of a second from 0.1 to 0.9.
- Audit Int** This screen is used to set the interval for running of EST. The display shows the current interval setting.
- Material Code** This screen is used to set the TMD measurement window timing. Window timing is based on a material type code from 0 to 7. The display shows MAT CODE. The counter shows the current material code number being used. This value is pre-set to 3.
- Time Constant** This screen indicates the slope of the decay curve over time for the tramp metal signal. The display shows TIME CON. The counter shows a number representing the slope of the curve from 1 to 999. The larger

the number, the more gradual the slope. The smaller the number, the steeper the slope. This screen is for display purposes only.

Filter

This screen is used to select the noise filter used on the TMD. There are three filters to choose from. Higher-numbered filters provide more sensitivity to tramp metal, but filter less electrical noise. The display shows FILTER. The counter shows the filter number from 0 to 3.

Operating Frequency

This screen is used to specify the operating frequency of the TMD. The display shows OP FREQ. The counter shows one of the following settings from 0 to 3:

- 0 = 900 Hz
- 1 = 780 Hz
- 2 = 660 Hz
- 3 = 1020 Hz

The usual setting is 0 (900 Hz).

Remote Front Panel

This screen indicates whether the TMD system supports a remote front panel connected to the control unit. The display shows REMOTE?Y or REMOTE?N.

Modbus Communications

This screen indicates whether the system is controlled by a PLC connected to the control unit over a serial communications line. The display shows MODBUS?Y or MODBUS?N.

If the TMD is controlled over a Modbus line (MODBUS?Y), the next screen in the scroll is ADDRESS. The counter shows the Modbus address of the control unit from 0 to 255. The next screen in the scroll is BAUD. The counter shows the baud rate of the serial line from 600 to 19200.

Switch Settings

These screens allow you to view the settings of the DIP Switches on the display board (refer to Section “DIP Switch Settings”)

The display shows the switches in the following order. The corresponding setting (ON or OFF) is shown in the counter. Press the down SCROLL key to move through the displays.

- Password protection (PSWD PRT)
- Speed sensor input (SPEED)
- Sync input (SYNC)
- Belt direction (BELT REV)
- Measure units (ENGLISH/METRIC)

Front Panel Tests

These screens allow you to test the indicators and keys on the front panel.

The first test screen is LAMP? N. Changing this to LAMP? Y and pressing ENTER tests the indicators by lighting each LED on the front panel individually. The bar graph segments light from the bottom up and the counter counts up from 000 to 999. This test completes automatically.

The second test screen is KEY? N. Changing this to KEY? Y and pressing ENTER initiates the key test. When you press ENTER, the display shows ENTER. When you press the up VALUE key, the display shows V UP, and so on. Each key press should result in a corresponding display. To end the key test and return the keys to their normal functionality, press RESET.

Software Version

This screen shows the version of TMD software installed. The display shows V XX.XX, where XX.XX is the version number.

Exit

This screen allows you to exit the setup screens and return to Run mode without having to SCROLL back up to the Run screen. The display shows EXIT?. To exit, press ENTER.

Error Messages

The TMD has built-in error detecting that recognizes and reports error and fault conditions in the system.

Error Conditions

When an error occurs, the ALARM LED lights and the error message appears on the display. The display shows the type of error that occurred (refer to Table 3 1: Error Messages). The counter shows the corresponding error number. An E in the first digit of the counter indicates an error rather than a fault condition.

To clear an error message from the Run screen, press the ENTER key. Correct the error condition, scroll to the error message display (the last display in the scroll), and press ENTER to clear the message.

NO.	MESSAGE	MEANING
E1	COLD ST	<p>The detector cold started on power up. Default values were used for calibration settings.</p> <p>Possible causes:</p> <ul style="list-style-type: none"> • Cold start DIP Switch is set to ON • Memory checksum problem
E2	RESETDIS	<p>The reset disable input is open. (This input is used for the optional marker feature.)</p> <p>You cannot reset the detector until the input is closed by resetting the marker. (This prevents you from restarting the belt without the marker in place.)</p>

Table 3–1. Error Messages

Fault Conditions

Faults indicate that the TMD found a failure in the electronics or a setting that does not allow the detector to operate. When a fault occurs, the ALARM LED lights and the alarm output relay is activated. If the TMD is in Run mode, the fault message appears on the display.

The display shows the type of fault that occurred (refer to Table 3-2: Fault Messages). The counter shows the corresponding fault number. An F in the first digit of the counter indicates a fault rather than an error condition.

To clear a fault message from the Run screen, press the ENTER key. Correct the fault condition, scroll to the error message display (the last display in the scroll), and press ENTER to clear the message. To return the TMD to Run mode, scroll up to the Run screen.

NO.	MESSAGE	MEANING
F1	XMIT FLT	Indicates an open or short circuit has been detected in the transmitter coil. May be due to faulty wiring or actual fault condition.
F2	SELFTEST	Indicates a microprocessor problem.
F3	BALANCE	The coil imbalance exceeds the ability of the detector to electronically “self-balance.” See 4.4.1
F4	HIGHPILE	The high pile input was not reset within 4 seconds after tripping.
F5	OVERLOAD	The input circuitry is saturated. Reduce gain, mechanically balance coils per 4.4.1 or remove the cause of the overload.
F6	AUDITCHK	Not yet implemented.

Table 3–2. Fault Messages

Setting up the TMD

This section guides you through the initial setup and calibration of your Oretronic III TMD. Once the TMD is set up correctly, few or no changes to the settings are required.

Before You Begin

Before you begin setting up and calibrating the TMD for your application, be sure that:

- The TMD has been installed both mechanically and electrically in accordance with the procedures in Chapter 2: Installing the TMD and the installation and field wiring drawings.
- You are familiar with the functions of all the keys, indicators, and displays on the TMD front panel.
- You have taken the required measurements (refer to Section “Determining Values to Use for Initial Setup”).
- You have a timing mark on your conveyor belt.
- You have a piece of tramp metal the average size to be detected.
- You power up the system 15 minutes before beginning setup.

Using the Display Scroll

When the TMD is in Setup/Calibrate mode, the display shows each individual variable that needs to be set up. The counter shows the current (default) value of the variable.

The up and down SCROLL arrow keys move the scroll of display “screens” up and down one screen at a time. To access a variable, press a SCROLL key to move the display to that variable. The Setup/Calibration Displays are referenced in Section “Initial Setup Procedure”.

Note: When either end of the display scroll is reached, scrolling ends. The scroll does not wrap.

Entering Values

The up and down VALUE arrow keys change the value of the variable shown in the counter. Pressing the up arrow increases the value. Pressing the down arrow decreases the value. Values increase or decrease only within the range for the individual variable.

To change a variable, press a VALUE arrow key until the value you want is displayed in the counter. You must press the ENTER key to use the new value. When the value of a variable has been changed but not entered, the value of the variable flashes as a reminder to press ENTER. If the variable has more than one digit, each one flashes individually. **Note:** After you press ENTER to change a variable, the display will show the message XXXX DNE, where XXXX indicates the variable.

Initial Setup Procedure

Follow this procedure for the initial setup of the Tramp Metal Detector. Refer the Setup/Calibration Displays references in the left margin for the order of the displays used during setup.

Note: When setting up or changing variables, the new values are not stored in system memory until you return to Run mode. If you power off the TMD while you are still in Setup/Calibrate mode, all changes are lost.

Set Up Displays

- SETUP? Y**
- CLIP DLY**
- BAR SENS**
- BAR LEN**
- BELT SPD**
- TIME DLY**
- TIME DUR**
- MAT**
- CODE**

1. Stop the conveyor belt.
2. Bump the conveyor belt until a 10-ft (3-m) section of belt, without splices or clips, is centered in the detection area.

There should not be a splice or clip within 4 ft (1.2 m) of the receiver coil on the return side.

3. Scroll to the high-level setup menu and put the TMD in Setup mode (SETUP? Y).
4. If your system uses a marking device, scroll to the TIME DLY display and enter the time, in seconds, it takes for tramp metal to move from the coils to the marking device. (Refer to Section “Determining Timed Delay”)

Range: 0.1–9.9 seconds
 Default: 1.0

5. Scroll to the TIME DUR display and enter the duration of the timed marking output in tenths of a second.

Range: 0.1–0.9 seconds
 Default: 0.9

6. If your system uses a belt clip detector, scroll to the CLIP DLY display and enter the distance, in feet, from the clip detector to a point six inches past the receiver coil. If no speed sensor is used, enter the time needed to pass the belt splice. (Refer to Section “Determining Clip Delay”)

If your system does not use a clip detector, enter 0 to turn off clip detection.

If your system uses two clip detectors and the time required to pass the belt splice is greater than 10.0 seconds, use the — — — on/off mode. Above 10.0, the on/off mode is used with variable speed belts where Clip Detector A input turns on the clip detector and stays on until Clip Detector B input turns it off.

Range: 0.0–30.0 ft, 0.0 – 10.0 seconds, — — — turn
 on/off mode
 Default: 0.5

Calibration

CALIB? Y

COIL BAL

COARSE

FINE

CLIP CORS

CORS FINE

AUD INT

TEST

EXIT

7. Scroll to the BELT SPD display.

If your system uses a speed sensor, the belt speed determined by the sensor will be displayed in the counter.

If your system does not use a speed sensor, enter the belt speed in feet/minute. . (Refer to Section “Determining Belt Speed”).

If the speed is greater than 999 feet/minute, set each digit to 9, and while the third digit is flashing, continue to press the up VALUE key. The display will change to thousand feet/minute with a decimal point and the letter “H” following the number.

Range: 1–1,200 ft/min

Default: 400

8. Scroll to the high-level calibration menu and put the TMD in Calibrate mode (CALIB? Y).
9. Scroll to the COIL BAL display and press ENTER to do a quick electronic balance of the TMD.

The display flashes QUIK BAL while the TMD balances.

10. Scroll to the COARSE display and press ENTER (without changing the value) to start the tramp metal coarse sensitivity auto-calibration.

The counter shows A0 and the display flashes AUTO MET to indicate that the calibration has started.

11. Slide the piece of tramp metal completely through the detection area (that is, between the transmitter and receiver coils) in the center of the belt at least three times in the direction of normal travel, then press ENTER.

The display flashes QUIK BAL while the system rebalances, and then returns to the COARSE display. The counter shows the new coarse sensitivity setting.

Range: 0–7

12. Scroll to the FINE display and press ENTER (without changing the value) to start the tramp metal fine sensitivity auto-calibration.

The counter shows A1 and the display flashes AUTO MET.

- Calibration
- CALIB? Y**
- COIL BAL**
- COARSE**
- FINE**
- CLIP CORS**
- CORS FINE**
- AUD INT**
- TEST**
- EXIT**

13. Slide the piece of tramp metal completely through the detection area at least three more times, then press ENTER.

The display shows MET DONE. The counter shows the new fine sensitivity setting.

Range: 0–999

14. If your system uses a clip detector, go on to Step 14.

If you do not have a clip detector, make sure the counter value for the CLIP DLY display is 0 (this turns off clip detection) and go to Step 19.

15. Start the conveyor belt.

16. Scroll to the CLP CORS display and press ENTER (without changing the value) to start the coarse clip sensitivity auto-calibration.

The counter shows A2 and the display flashes AUTO CLP to indicate that the calibration has started.

17. Wait for the timing mark to pass over a reference point and let at least five complete belt revolutions pass. Then press ENTER.

The display flashes QUIK BAL while the system rebalances, and then returns to the CLP CORS display. The counter shows the new coarse clip sensitivity setting.

Range: 0–7

18. Scroll to the CLP FINE display and press ENTER (without changing the value) to start the fine clip sensitivity auto-calibration.

The counter shows A3 and the display flashes AUTO CLP.

19. Let at least five more belt revolutions pass, then press ENTER.

The display shows CLP DONE. The counter shows the new fine clip sensitivity setting.

Range: 0–999

20. Scroll down to the EXIT? display and press ENTER. Scroll to the high-level setup menu and put the TMD in back into Setup mode (SETUP? Y).

If your system uses bar/rod detection, go on to Step 21.

If you do not use bar/rod detection, make sure the counter value for the BAR SENS display is 0 (this turns off bar/rod detection) and go to Step 22.

21. Scroll to the BAR SENS display and enter the sensitivity of the TMD to long bars or rods. (For information about setting the bar/rod sensitivity, refer to Section “Adjusting for Bar/Rod Detection” and Section “Passing Bars or Rods Undetected”.)

Range: 0–9
Default: 0

22. Scroll to the BAR LEN display and enter the maximum length, in feet, of bar or rod to detect.

Range: 1.0–10.0 ft
Default: 10.0

23. This completes the initial setup procedure.

You can test your setup and calibration by scrolling to the TEST display (in the Setup scroll).

When TEST is displayed, you can pass your test piece of tramp metal to test your calibration without actuating the alarm relay outputs. The TMD will otherwise operate normally; the ALARM LED will light, and pressing RESET will RESET the alarm and zero the counter.

24. Scroll to the EXIT? display and press ENTER.

This puts the TMD in normal Run mode and saves the setup values in system memory. The display shows count, counter shows total, normal LED is lit.

You may want to scroll through all of the Setup and Calibration displays again and record the values.

Chapter 4 Maintaining & Troubleshooting

This chapter provides information about TMD maintenance and troubleshooting. It includes pointers for routine maintenance and suggestions for diagnosing operational problems.

The maintenance information in this chapter should be sufficient to meet your service needs. If you encounter a problem that requires technical assistance, please call your service representative (refer to Service and Repair Information on page 5-1 for telephone numbers).

Overview

You can expect the Oretronic III TMD system to operate satisfactorily and hold its calibration for months with simple routine maintenance.

The Oretronic III control unit is a solid-state device, and as such, requires minimal maintenance.

Routine Maintenance

Keep the area around the TMD free from rocks and material build-up.

The TMD system can be washed down with water and meets NEMA Type 4X standards. Do not add harsh chemicals, caustics, or disinfectants to the wash down solution.

The control unit enclosure can be wiped clean with a damp cloth, and if necessary, a mild detergent. Never use abrasive cleaners, especially on the display windows. Keep the enclosure door tightly closed to prevent dirt infiltration.

As a preventive measure, check all wires, plugs, and integrated circuits in the control unit to make sure they are tight in their connectors.

The idlers on each side of the TMD coil support structure should be greased according to the manufacturer's specifications.

Make sure that the conveyor belt is running true to the conveyor centerline in the detection area to prevent damage to the coil support structure and coil(s).

Troubleshooting

If your TMD is not detecting reliably or your calibrations are providing unexpected results, there are several things you can do to determine the cause of the problem.

Always begin with a visual inspection, not only of TMD components but also of the conveyor belt, the idlers, and all optional equipment.

The TMD is able to detect certain internal errors and faults and provide indications of them on the front panel. Refer to Error Messages on page 3-14 for information about error and fault messages. The diagnostic screens also display the current settings of the DIP Switches and help with electronic coil balancing.

If your system operates but is not working as expected, there are adjustments you can make to the TMD device setup and calibration settings to make it work better. First, you must determine what is causing the problem and what you can do to correct it.

Visual Inspection

If you are experiencing operational problems with the TMD, a quick visual inspection may reveal the source of the problem. Check the following items before proceeding to more specific troubleshooting procedures.

Refer to Configuring the TMD on page 2-12 for the correct settings of the switches and jumpers mentioned below.

- Check power
 1. Make sure that SW6 (power) on the CPU board is set to ON.
 2. Make sure that SW5 (AC voltage selector) is set to the correct position.
 3. Check the fuses.
- Check connections
 1. Make sure all terminations are secure.
 2. Make sure all option DIP Switches (SW1) on the display board are set to the correct positions.
 3. Make sure all TMD wiring and installation is correct according to the drawings provided for your system.

Diagnosing and Correcting Problems

When you calibrate the TMD during initial setup, the microprocessor “imprints” the signal level produced by the piece of tramp metal you use for the calibration. The TMD then trips when tramp producing that signal level or greater passes through the detector.

However, setup and calibration were done with the conveyor belt stopped or running empty. Because background noise caused by material may be different with the belt running loaded, you should observe the TMD for a day or two before changing the device setup or calibration settings.

There are two basic types of problems you could be having with the TMD: false tripping or passing tramp undetected. Both of these problems are costly. False trips stop the conveyor and interrupt the process flow. Undetected tramp damages process machinery.

Common reasons for false tripping include:

- Coil imbalance
- Sensitivity set too high
- Improper bar/rod detection
- Improper clip (belt splice) detection

Common reasons for passing tramp undetected include:

- Sensitivity set too low
- Tramp is too small
- Coil damage
- Detector malfunction

The remainder of this chapter describes the diagnostic processes for these problems and offers suggestions for correcting them.



WARNING

Failure to follow safe installation and servicing procedures could result in death or serious injury.

- Make sure only qualified personnel perform installation and maintenance procedures in accordance with the instructions in this manual.
- Allow only qualified electricians to open and work in the electronics cabinets, power supply cabinets, control cabinets, or switch boxes.
- Covers over the electronics and rotating parts must always remain in place during normal operation. Remove only for maintenance, with the machine's power OFF. Replace all covers before resuming operation.
- During maintenance, a safety tag (not supplied by the factory) is to be displayed in the ON/OFF switch areas instructing others not to operate the unit (ANSI:B157.1).

False Tripping

False tripping means that something other than the metal the TMD is set up to detect is causing it to trip. The most common problem is a sensitivity setting that is too high for the amount of background noise present. This makes it difficult for the TMD to distinguish between the signal produced by tramp metal and the background signal. Another common problem is coil imbalance, which can cause the receiver coil to generate output signals when there is no tramp passing.

If your TMD is false tripping, use the procedures in this section to help determine the cause. The procedures are written as though you are familiar with using the operator interface. If you are not familiar with the operator interface, please read the detailed descriptions of the front panel keys, indicators, and displays in Chapter 3 of this manual before beginning any of these procedures.

Correcting Coil Imbalance

Coil imbalance can result from the transmitter and receiving coils not being aligned well. It can also result from different amounts of metal in the conveyor structure on each side of the coils.

Use this procedure to balance the coils. Always perform this procedure first, before trying to determine any other cause of false tripping.

**WARNING**

Keep hands and clothing away from all moving or rotating parts.

1. Stop the conveyor belt.
2. Clear the burden off the belt for four feet on each side the coil structure.

Also, check the immediate area around the support structure and on the coils and remove any loose metal objects.

3. Place the TMD in Setup/Calibrate mode.
4. Scroll to the MAT CODE display and verify that the material type code shown in the counter is 3. (For mineral ores, this value should be 4.)
5. Scroll to the COARSE display and write down the “as found” coarse sensitivity value shown in the counter, and then set the value to 2.
6. Scroll to the COIL BAL display and observe the LED bar graph.

There should be fewer than five LEDs lit on either side of the middle of the bar graph. The LEDs may be going on and off and changing sides (from top to bottom and visa versa).

If five or more LEDs are lit, you need to manually balance the coils.

If the coil imbalance exceeds the ability of the TMD to self-balance, the ALARM indicator lights and the BALANCE fault message appears in the display. Press ENTER to clear the message and proceed with Step 7.

7. Adjust the coil position for your TMD model as follows.

For a dual coil TMD:

- Use the adjusting bolts on the swing arm stop.
- As the transmitter coil is moved, the bar graph display will change. Find the position where the minimum number of LEDs in the middle of the bar graph are lit.
- If the balance improves significantly, proceed with Step to “fine tune” the coil balance.
- If adjusting the transmitter coil does not affect the bar graph significantly, move the TMD coil frame a few inches towards

head pulley or tail pulley to see if the balance improves significantly, then adjust it to the best position possible. If moving the frame does not help balance then, go on to 4.4.2 Finding the Source of Mechanical or Electrical Noise.

For a single coil TMD:

- Loosen the plastic bolts that hold the coil to the frame.
- Move the coil from side to side. The slots in the coil will limit the coil travel.
- As the coil is moved, the bar graph display will change. Find the position where the minimum number of LEDs in the middle of the bar graph are lit.
- If the balance improves significantly, proceed with Step 8 to “fine tune” the coil balance.
- Retighten the plastic bolts holding the coil to the frame.
- If adjusting the coil does not affect the bar graph significantly, adjust it to the best position possible and go on to 4.4.2 Finding the Source of Mechanical or Electrical Noise

8. Scroll to the COARSE display and set the value to 5.

This increases the sensitivity of the TMD so you can fine-tune the coil balance.

9. Scroll to the COIL BAL display and observe the bar graph again.

The bar graph may be “noisier” than it was in Step 6 (there may be more LEDs lit). This is because the sensitivity is set higher.

10. Repeat Steps 7 and 8, increasing the coarse sensitivity value each time.
11. When you are satisfied with the coil balance, scroll to the COARSE display and return the value to the “as found” value you recorded in Step 5.

Finding the Source of Mechanical or Electrical Noise

False tripping often occurs from mechanical vibrations that produce background noise. The TMD software has signal processing to recognize the difference between a signal from metal passing through the coils and a signal from metal vibrating in the region of the coils. However, severe metal vibrations can sometimes produce the same signal as the metal passing through the coils.

Electrical disturbances from the conveyor belt motor or the wiring from the motor may also produce noise that interferes with TMD operations. Even other electrical systems near the TMD may be generating the noise.

Follow this procedure to find the source of mechanical or electrical noise.

1. Balance the coils as evenly as possible using the procedure from “Correcting Coil Imbalance”.
2. Scroll to the fine display and write down the “as found” fine sensitivity value shown in the counter, then set the value to 950.
3. Watching the LED bar graph, press a Value key to increase or decrease the fine sensitivity value until about 70 percent of the LEDs are lit. (The actual number of bars lit will change continuously; 70 percent is an average.)



CAUTION

Keep hands and clothing away from all moving or rotating parts.

1. Start the conveyor belt.

Do not run any burden at this time.

2. Observe the bar graph.

The number of LEDs lit should not change.

If the noise level (number of LEDs lit) increases with the conveyor belt running, the noise could be caused by mechanical vibrations or electrical disturbances.

3. With the conveyor belt still running empty, check the area in the immediate vicinity of the coils for possible sources of mechanical vibration.

The larger the size and surface area of the metal, the less the vibration required to cause problems.

- The coil support structure should not vibrate or sway.
- The coil(s) should be firmly bolted to the structure and should not vibrate.
- There should be no conveyor idlers or other moving conveyor parts in the area of the coils. (The minimum distances for moving components are given in the system installation drawings.)
- There should be no vibrating grates or covers in the area.

If you find a possible source of mechanical vibration, correct the problem and repeat this procedure to verify that it was the problem.

If the noise level increases when the conveyor is run empty and mechanical vibrations do not appear to be the problem, the problem may be electrical noise from the conveyor motor or electrical wiring from the motor.

**WARNING**

High voltage that may be present on leads could cause electrical shock.

- All switches must be OFF when checking input AC electrical connections, removing or inserting printed circuit boards, or attaching voltmeters to the system.
- Use extreme caution when testing in, on, or around the electronics cabinet, PC boards, or modules. There are voltages in excess of 115 V or 230 V in these areas.

4. Check system wiring and installation to be certain it conforms to the recommended distances specified in the wiring diagram for your system or the Field Wiring Diagram (D07328C-E201).

If you find a problem with the wiring, correct it.

**CAUTION**

The coil wiring must be run in a separate conduit from any power wiring.

If the system appears to be installed and wired correctly and there is still a high level of noise when the conveyor is run, other electrical systems may be generating the noise.

5. With the conveyor running empty, turn off other systems near the TMD one at a time while observing the bar graph.

Turning off the source of the electrical noise will cause the number of LEDs lit to decrease, identifying that system as the one causing the problem.

6. If you identify a definite source of the electrical noise, correct the problem.

A typical solution may be re-routing wiring carrying large currents. In some instances, the only practical solution may be relocating the TMD to some other less noisy location.

If you cannot identify a definite source of the electrical noise, it may be helpful to change the operating frequency of the TMD.

7. Scroll to the OP FREQ display and change the operating frequency value from 0 to one of the other values (0 = 900 Hz, 1 = 780 Hz, 2 = 660 Hz, 3 = 1020 Hz).

8. Observe the bar graph.

If the number of LEDs lit decreases, this is a better operating frequency for the TMD. Skip to Step 14.

If the number of LEDs lit does not decrease, try each value. If the number still does not decrease, change the operating frequency back to 0 and go on.

It may also be helpful to change the filter setting used by the TMD. Although the default filter—filter 1—usually provides the best noise reduction, filter 0, 2, or 3 may work better in some installations.

9. Scroll to the FILTER display and change the value.

10. Observe the bar graph.

If the number of LEDs lit decreases, this is a better filter for the TMD. Go on to Step 14.

If the number of LEDs lit does not decrease, try each value. If the number still does not decrease, change the filter back to 0 and go on.

11. Scroll to the FINE display and return the value to the “as found” value recorded in Step 2.

Adjusting for High Product Noise (Mineral Ores)

With some highly conductive ores, the default measurement window for detecting metal will cause false tripping similar to high electrical noise when the ore is conveyed. The typical indication of this situation is a low noise level when the conveyor is run empty and a higher level when it is run loaded (as indicated by the bar graph).

This noise signal can be overcome by changing the location of the measurement window, which determines the timing of the measurement. Because the magnetic field from mineral ore takes longer to decay, you need to move the measurement window farther out on the time scale so the TMD will not be as sensitive to the signal from the ore. To move the measurement window farther out on the time scale, you increase the material type code number.

Note: Before beginning this procedure, make sure the FILTER setting is 1. Filter 1 provides the best reduction of product noise.

Follow this procedure to adjust the sensitivity of the TMD for mineral ores.

1. Balance the coils as evenly as possible using the procedure from “Correcting Coil Imbalance”.

Make sure that the MAT CODE value (Step 4 of the coil balancing procedure) is set to 4.

2. Scroll to the COARSE display and perform both a coarse and fine metal auto-calibration. (Refer to the Initial Setup Procedure in Chapter 3.)

The coarse and fine values will be different from the values obtained using material type code 3.



CAUTION

Keep hands and clothing away from all moving or rotating parts.

3. Start the conveyor belt and run material through the coils

Observe the noise level on the bar graph. The noise level should have decreased (fewer LEDs lit). If it did, use this material type code.

If the noise level increased, the problem is not caused by the type of material conveyed. Go to Step 5.

4. If the noise level from the ore is still too high, scroll to the MAT CODE display, increase the value by one, and repeat Steps 2 and 3.

The valid numbers for material type code are 0–7.

If you tried using the values 4, 5, 6, and 7 and there was no significant improvement or the noise level increased, the problem may be mechanical or electrical noise or the tramp to be detected may be too small for existing system conditions.

5. Scroll to the MAT CODE display and set the value back to 3.

You may want to try the procedure from Section “Finding the Source of Mechanical or Electrical Noise” to see if that may be the problem.

Adjusting for Bar/Rod Detection

The TMD bar/rod detection option allows you to set a specific sensitivity calibration for bars or rods that are small in diameter and one to ten feet in length. This enables the TMD to trip on the weaker, longer-duration signals produced by these metal objects, which are generally quite different in size and shape from the tramp. When bar/rod detection is active and a weaker signal causes a trip, the display shows LONG BAR.

The TMD is much more sensitive to noise, both electrical and mechanical, when the bar/rod option is active. You also specify the maximum length of bar rod for the TMD to detect. This measurement, along with the belt speed, determines an integrating time at which the TMD takes its bar/rod measurements. Any of these parameters may need to be adjusted.

Before beginning this procedure, scroll to the BAR SENS display and check the number shown in the counter. If the counter shows zero, bar rod sensitivity is not causing the problem because the option is not active.

If any number other than zero appears in the counter, the option is active. The larger the number (from 1 to 9) the more sensitive the TMD to both bar/rod and noise.

If you suspect the bar/rod option may be causing false trips, follow this procedure.

1. Reset the TMD (press the RESET key) and wait for a false trip.
2. Check the display to see if it shows LONG BAR.

If it does, the bar/rod option is likely causing the problem. There are three corrective actions you can try, as described in the next steps.

3. Scroll to the BAR SENS display and decrease the sensitivity of the bar/rod detector by entering a lower number.
4. Reset the TMD (press the RESET key) and wait for a false trip.

If the display still shows LONG BAR, the coils may be unbalanced or there may be too much system noise.

5. Follow the procedure in Correcting Coil Imbalance on page 4-4 to balance the coils. Follow the procedure in Mechanical or Electrical Noise on page 4-7 to reduce system noise.

Adjusting for Clip (Belt Splice) Detection

Some false trips may occur from the clips used for belt repair or splicing. Check the installation of the clip detector(s) to make sure they are positioned correctly. (Refer to the appropriate Installation Placement drawing for your system.)

Make sure you have correctly determined the clip delay, which is designed to prevent the TMD from tripping when a clip goes through. (Refer to “Determining Clip Delay”.) Calibrate the system for clip detection and delay as described in Section “Determining Clip Delay”.

A false trip on a clip can usually be easily diagnosed. The TMD will trip just as or just after a clip has passed. If the conveyor is wired to stop on a trip, the clip will generally be the same distance downstream from the coils each time the trip occurs and the belt is shut down. False tripping from clips is generally caused by one of three conditions:

- The clip detector did not see the clip
- The clip delay is too short
- The clip sensitivity is too high

Follow this procedure to determine whether the clip detector saw the clip.

1. Reset the TMD (press the RESET key) and wait for a false trip.
2. Check the display to see if it shows CLIP.
3. If the display does not show CLIP, scroll to the CLIP DLY display and check the value shown in the counter.

If the value is 0, clip detection is not active.

4. Determine the correct clip delay (refer to Determining Clip Delay on page 2-17) and enter the value.
5. Repeat Steps 1 and 2 of this procedure.

If the display still does not show CLIP, the clip detector is not working properly.

Follow this procedure to determine why the clip detector is not working properly.

Note: You will need a digital volt meter (DVM) to complete this procedure.

1. Check the system wiring based on the wiring diagram for your system or the Field Wiring Diagram (D07328C-E201) in Appendix D.
2. Check the operation of the clip detector by placing a metal screwdriver on the end of the upstream clip detector.

The display should show CLIP for the duration of the clip delay. If CLIP is displayed, go on to the next procedure.



WARNING

High voltage that may be present on leads could cause electrical shock.

- All switches must be OFF when checking input AC electrical connections, removing or inserting printed circuit boards, or attaching voltmeters to the system.
- Use extreme caution when testing in, on, or around the electronics cabinet, PC boards, or modules. There are voltages in excess of 115 V or 230 V in these areas.

3. If CLIP is not displayed, disconnect the clip detector wires at the control unit.
4. Using a DVM, measure the voltage at TB2, terminals “7” and “8.”
5. The voltage should be approximately 24 VDC.
6. If voltage is present, the clip detector is defective and needs to be replaced.

If voltage is not present, the TMD may have been damaged by a clip detector wiring problem. Both the clip detector and the CPU board should be replaced.

If you have determined that the clip detector is functional but still not working properly, it is not seeing the clips on the belt. This may be because the clip detector is too far from the clip and is out of the detection range or because the clip is too small to detect.

Note: The clip detector is to be mounted 3 to 4 inches away from the first idler toward the tail pulley and the coil support structure. If it is not mounted according to the installation placement drawings, the clip detector may intermittently miss clips.

1. If the clip detector is out of detection range, readjust the clip detector. (Refer to the appropriate Installation Placement drawing for your system.)
2. If the clip is too small, add an additional clip on the side of the belt. Mark the section of the belt where the false trip occurs and inspect this section of the belt when it is stopped.

If the clip detector is functional and is detecting all the clips, CLIP shows on the display, and the TMD is false tripping on the clips, the problem is too high a clip sensitivity.

Follow this procedure to adjust the clip sensitivity.

1. Scroll to the CLP CORS display and record the clip coarse sensitivity value shown in the counter.
2. Scroll to the CLP FINE display and record the clip fine sensitivity value shown in the counter.
3. Perform an auto-calibration for both coarse and fine clip sensitivity as described in Section “Initial Setup Procedure”.
4. Scroll to the displays and record the new CLP CORS and CLP FINE values.
5. Compare the old and new CLP CORS values.

If they are not the same, the clip sensitivity has been changed by the auto-calibration. Go on to Step 6.

If they are the same, go to Step 8.

6. Run the conveyor and check for false trip from clips. Observe the LED bar graph.

When the largest clip on the belt passes, 10 to 12 LEDs will light.

7. If the TMD does not false trip and the bar graph shows 10 to 12 LEDs on the largest clip, the old CLP CORS value was incorrect; the new value should be used.

Note: The number of LEDs displayed for the clip(s) may vary slightly as the clip passes through from one time to the next. This is caused by a slight non-linearity in the electromagnetic field near the receiver coils and will not cause any problem.

8. Compare the old and new CLP FINE values.

If they are within 50 of each other or the new value is less than the original value, the auto-calibration set the clip sensitivity too high. You will have to set clip sensitivity manually.

If the CLP FINE value is less than 500, there may not be enough range in the clip fine adjustment. Go on to Step 9.

If the CLP FINE value is greater than 500, go to Step 14.

9. Scroll to the CLP CORS display.

10. Decrease the clip coarse sensitivity value shown in the counter by and press enter.

11. Scroll to the clip fine display and press enter (without changing the value) to start an auto-calibration.

12. Allow at least two complete revolutions of the conveyor belt, then press ENTER.

The display shows CLP DONE. The counter shows the clip fine sensitivity setting.

13. Run the conveyor and watch for false trips.

14. If no false trips occur, the CLP FINE value is set correctly. Do not proceed with any further steps in this procedure unless additional false tripping occurs.

If false trips are still occurring, go on to Step 14.

15. Decrease the CLP FINE value by 10 and press ENTER.

16. Run the conveyor and watch for false trips.

If false trips from the clip still occur, continue decreasing the CLP FINE value by 50 until the largest clip passes without tripping the detector.

If the CLP FINE value reaches 500 and false trips are still occurring, scroll to the CLP CORS display and repeat this procedure from Step 10.

Passing Tramp Undetected

There are a number of reasons why the TMD may pass tramp undetected. The detector may be incorrectly wired or installed, the metal sensitivity number may be too low, the size of the tramp may be too small for the coil size and separation, the coils, or junction box may be damaged, or the TMD may be malfunctioning.

Tramp may also pass undetected if your system uses clip detection and the size of the clip(s) is large compared to the size of the tramp you are trying to detect. If there should happen to be tramp metal on top of a clip, the TMD may not detect the metal because it is letting the clip pass.

If your TMD is passing tramp undetected, use the procedures in this section to help determine the cause. The procedures are written as though you are familiar with using the operator interface. If you are not familiar with the operator interface, please read the detailed descriptions of the front panel keys, indicators, and displays in Chapter 3 of this manual before beginning any of these procedures.

Adjusting Metal Sensitivity

The most common cause of undetected tramp is having the metal sensitivity setting too low for the tramp you are trying to detect. Whenever you calibrate the TMD for tramp metal, make sure you use the same size, shape, and type of metal for the calibration that you expect to trip the detector during normal operation.

The TMD is designed so that when it is auto-calibrated, the threshold for a trip is just slightly less than the signal seen when the metal was passed during the calibration. A small irregularity in the shape of the tramp or a variation in placement between the coils will result in a slightly different strength signal. For these reasons, a round ball gives the most consistent calibration results. Even using a ball for calibration, however, the metal threshold value may vary a few digits from calibration to calibration.

Follow this procedure to adjust the metal sensitivity of the TMD.

1. Perform an auto-calibration for both coarse and fine metal sensitivity as described in Section “Initial Setup Procedure”.
2. Place the TMD in Run mode and pass the test tramp through the coils in the normal direction of travel.

If the TMD does not trip, observe the bar graph. If the LED level on the bar graph does not increase when the tramp is passed through the coils, there is a more serious problem than a low sensitivity setting. Go on to “Testing for Coil or Junction Box Damage” and “Determining TMD Malfunction”.

If the TMD does not trip, but the LED level on the bar graph increases when the tramp is passed, go on to Step 3.

3. Pass the test tramp through the coils in the opposite direction of normal travel.

If the TMD trips, the polarity of the receiver coil is reversed. Go on to Step 4.

If the TMD does not trip when the tramp is passed in either direction, but the LED level increases (indicating a metal signal), the sensitivity values need to be adjusted manually. Go to Step 7.

4. Check the marking on the receiver coil to make sure it is installed correctly. (Refer to the appropriate Outline, Mounting and Assembly, Coil Stand, drawing.)
5. If the coil is installed correctly, reverse the black and clear wires from the receiver coil in the control unit or change the position of DIP Switch 4 on the display board, then power cycle the TMD.
6. Test the detector by passing the metal through in the direction of normal travel.
7. To manually adjust the metal sensitivity values, place the TMD in Calibrate mode and scroll to the FINE display.
8. Using the down VALUE key, increase the FINE sensitivity value by 10 and press ENTER.
9. Place the TMD in Run mode and pass the test tramp through the coils.

If the TMD trips, the FINE sensitivity value is set correctly.

If the TMD does not trip, repeat Steps 7–9 until you find a fine sensitivity value that will trip the detector every time. If the FINE value reaches 950 and this is still not sensitive enough, you should adjust the coarse sensitivity value. Go on to Step 10.

10. Place the TMD in Calibrate mode and scroll to the COARSE display.
11. Using the up VALUE key, increase the COARSE value by 1 and press ENTER.
12. Place the TMD in Run mode, pass the test tramp through the coils, and check for a trip.

If the sensitivity is still not correct for your system, repeat Steps 7–12 of this procedure until it is.

If this procedure does not increase the sensitivity enough, try the procedures in Finding the Source of Mechanical or Electrical Noise on page 4-7. For a dual coil TMD, you can also try lowering the transmitter coil to the minimum height possible (refer to Outline, Mounting and Assembly, Coil Stand (D07328C-A003)).

If these steps do not result in adequate sensitivity, you may need to change the material type code.

Note: Adjusting metal sensitivity is performed the same for both double and single coil detectors.

Changing the Material Type Code to Adjust Sensitivity

Detecting small-sized tramp metal, especially small stainless steel tramp may require changing the material type code used by the TMD. This may not result in a dramatic sensitivity increase because a reduction of 1/2 in tramp size may result in a reduction of only 1/4 to 1/16 of the signal; the signal reduction is a function of both size and type.

First, you must determine how well the TMD is working with the current material type code (which should be 3).

1. Balance the coils using the procedure in Correcting Coil Imbalance on page 4-4.
2. Scroll to the COIL BAL display and observe the LED bar graph.
3. Increase the COARSE and FINE sensitivity values until 5 LEDs are lit in the COIL BAL diagnostic display.

This may require a number of cycles of changing and observing.

4. When 5 LEDs are lit, record the COARSE and FINE values.
5. Scroll to the MAT CODE display and decrease the value shown in the counter by 1. Press ENTER.
6. Balance the coils again using the procedure in Correcting Coil Imbalance on page 4-4.
7. Scroll to the COARSE display and enter the value recorded in Step 4.
8. Scroll to the FINE display and enter the value recorded in Step 4.
9. Scroll to the COIL BAL display and observe the LED bar graph.

If fewer than 5 LEDs are lit, the TMD is functioning properly at this material type code and the sensitivity will be greater than it was with the previous material type code.

Note: The lower the material type code number, the greater the sensitivity to conductive materials other than tramp metal. In most instances, this will not be a problem. If a problem should occur, refer to Adjusting for High Product Noise (Mineral Ores) on page 4-10.

If more than 5 LEDs are lit, the TMD may still function properly at this material code setting.

10. Perform an auto-calibration for coarse and fine metal sensitivity as described in Section “Initial Setup Procedure” and test the system to see if it trips on tramp correctly.
11. If still greater sensitivity is required, repeat this procedure until you have the sensitivity you need.

Testing for Coil or Junction Box Damage

If you suspect that coil or junction box (if used) damage may be causing the TMD to operate improperly, follow the procedures in this section to test for damage.

These procedures involve testing wiring on the CPU board (and in the junction box, if your system uses one) using an ohm meter.

Figure 4-1 shows the location of the terminals on the bottom left of the CPU board.

⚠ WARNING

Failure to follow safe installation and servicing procedures could result in death or serious injury.

- Make sure only qualified personnel perform installation and maintenance procedures in accordance with the instructions in this manual.
- Allow only qualified electricians to open and work in the electronics cabinets, power supply cabinets, control cabinets, or switch boxes.

⚠ WARNING

High voltage that may be present on leads could cause electrical shock.

- All switches must be OFF when checking input AC electrical connections, removing or inserting printed circuit boards, or attaching voltmeters to the system.
- Use extreme caution when testing in, on, or around the electronics cabinet, PC boards, or modules. There are voltages in excess of 115 V or 230 V in these areas.

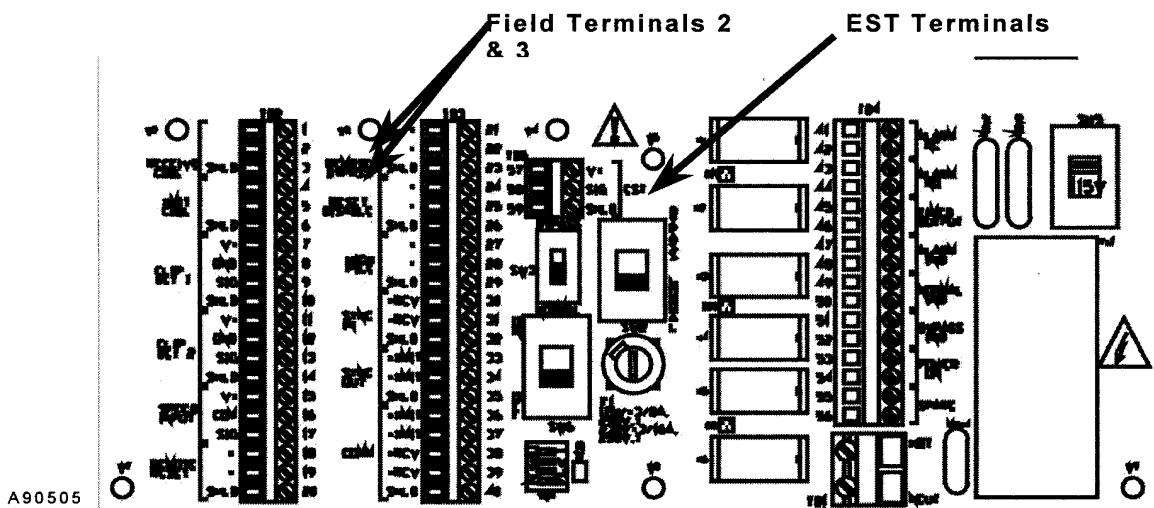

Figure 4–1. Terminals on the CPU Board

Testing the Transmitter Coil

Follow this procedure to test the transmitter coil if your system does not have a junction box.

1. Turn off power to the control unit (SW6).
2. Disconnect the transmitter coil wires from field terminals 4 and 5.
3. Measure the resistance of the coil.

If the ohm meter does not show 2–3 ohms, the transmitter coil is bad.

If the transmitter coil resistance is approximately 2–3 ohms, the transmitter coil, its wiring, and its portion of the CPU board is all right. Check the receiver coil.

If your system uses a junction box, follow this procedure to test the transmitter coil.

1. Turn off power to the control unit (SW6).
2. Disconnect the transmitter coil wires from field terminals 4 and 5.
3. Measure the resistance of the coil.

If the transmitter coil resistance is approximately 2–3 ohms, the transmitter coil, its wiring, and its portion of the CPU board is all right. Check the receiver coil.

4. If the ohm meter does not show 2–3 ohms on the transmitter coil wires, measure terminals 24 and 25 at the junction box.

If 24–25 at the junction box are 2–3 ohms, the cable from the junction box to the control unit is bad.

Testing the Receiver Coil

Follow this procedure to test the receiver coil if your system does not have a junction box.

1. Turn off power to the control unit (SW6).
2. Disconnect the receiver coil wires from field terminals 1 and 2.
3. Measure the resistance of the coil.

If the resistance is greater than 500 ohms, the receiver coil is bad.

If the receiver coil resistance is approximately 450–500 ohms, the receiver coil, its wiring, and its portion of the CPU board is all right.

If your system uses a junction box, follow this procedure to test the receiver coil.

1. Turn off power to the control unit (SW6).
2. Disconnect the receiver coil wires from terminals 121 and 222 at the junction box.
3. Measure the resistance of the coil.

If the resistance is greater than 500 ohms, the receiver coil is bad.

If the receiver coil resistance is approximately 450–500 ohms, the receiver coil, its wiring, and its portion of the CPU board is all right.

4. If the receiver coil resistance is all right, reconnect the wires to the terminals in the junction box.
5. Disconnect the receiver coil wires from field terminals 1 and 2 in the control unit.
6. Measure the resistance of the coil.

If the receiver coil resistance is greater than 2,500 ohms, the wiring to the junction box or the junction box circuit is bad.

Determining TMD Malfunction

If the TMD is not functioning correctly, follow the test procedures in this section to help determine the problem.



WARNING

Failure to follow safe installation and servicing procedures could result in death or serious injury.

- Make sure only qualified personnel perform installation and maintenance procedures in accordance with the instructions in this manual.
- Allow only qualified electricians to open and work in the electronics cabinets, power supply cabinets, control cabinets, or switch boxes.



WARNING

High voltage that may be present on leads could cause electrical shock.

- All switches must be OFF when checking input AC electrical connections, removing or inserting printed circuit boards, or attaching voltmeters to the system.
- Use extreme caution when testing in, on, or around the electronics cabinet, PC boards, or modules. There are voltages in excess of 115 V or 230 V in these areas.

1. Turn on power to the control unit (SW6).
2. If the displays do not light, check power wiring on TB1.
3. If the line voltage setting is not correct for your detector (SW5), correct it.
4. Turn the power switch (SW6) off.
5. Remove fuse (F1) and test it.

If the fuse tests good, put it back into the fuse holder and continue with this procedure.

If the fuse tests bad, go to the next procedure.

6. Turn the power switch back on.
7. If the displays do not light, turn the power switch off and test the fuse again.
8. Check the connectors on the CPU board and the ribbon cable to the display board for correct mating on boards.

Re-insert any connector that may have come loose during shipping or installation.

9. Check for coil or junction box damage using the procedures in “Testing for Coil or Junction Box Damage”.
10. Turn the power switch back on.

If the displays do not light, the TMD has been damaged and must be replaced.

If the fuse tested bad in the first procedure:

1. Replace the fuse with the correct sized fuse.
2. Turn the power switch back on.
3. If the displays do not light, turn the power switch off.
4. Test the fuse again.

If the fuse tests good, follow Steps 8–10 in the first test procedure.

If the fuse tests bad, continue with this procedure.

5. Disconnect all wiring to the CPU board except the power on TB1.
6. Replace the fuse with the correct-sized fuse.
7. Turn the power switch back on.
8. If the displays do not light, turn the power switch off.
9. Test the fuse again.

If the fuse tests good, follow Steps 8–10 in the first test procedure.

If the fuse tests bad, the TMD has been damaged and must be replaced.

The previous procedure should leave you with a functioning display with no field wiring except incoming power. The next test is to determine whether a peripheral system component may be causing the fuse to blow.

You will be connecting components to the CPU board one at a time until the fuse blows. Refer to the field wiring diagram for your system or the Field Wiring Diagram (D07328C-E201) in Appendix D for correct wiring connections.

The basic procedure for testing components is:

1. Turn the power switch (SW6) off.
2. Wire in a component.
3. Turn the power switch on.
4. Check the front panel.

If the displays are lit, that component did not blow the fuse. Repeat the procedure for the next component.

If the displays do not light, the fuse is blown. The wiring for that component is causing a problem.

Wire in the components, one at a time, in the following order:

- Transmitter coil
- Clip detector A
- Clip detector B
- High pile detector
- SYNC input
- Receiver coil
- Remote panel
- Alarm outputs

If all of the system wiring tests all right, go on to the next procedure for checking the TMD configuration.

1. Turn on power to the control unit (SW6).
2. Place the TMD in Setup/Calibrate mode.
3. Scroll to the MAT CODE display.
4. The value shown in the counter should be 3.
5. If the MAT CODE value is not 3, change it to 3 and press ENTER.

If you changed the value, rebalance the coils using the procedure in Correcting Coil Imbalance on page 4-4.

6. Scroll to the COARSE display.
7. Set the coarse sensitivity value to 6 and press ENTER.

If a BALANCE fault message appears in the display, rebalance the coils using the procedure in Correcting Coil Imbalance on page 4-4.

8. Scroll to the FINE display.
9. Set the fine sensitivity to a value that lights 5 LEDs on the bar graph and press ENTER.

If it is not possible to light 5 LEDs, decrease the value to 10.

10. Place the TMD in Run mode.
11. Pass a large piece of tramp or steel (3 inches or more in diameter) through the coils while watching the bar graph.

If the number of lit LEDs increases when the metal passes through the coils, the TMD is functional.

12. If no change in the bar graph occurs when the metal is passed through the coils, check all the wiring and installation.

If no abnormalities are found, the TMD is damaged and must be replaced.

Passing Bars or Rods Undetected

Bar/rod detection is determined by four factors:

- Coil balance
- Belt speed
- Bar/rod sensitivity
- Bar/rod length

If there is a problem with any of these, the TMD may pass bars or rods undetected.

If your TMD is passing bars or rods undetected, use the procedure in this section to help determine the cause. The procedure is written as though you are familiar with using the operator interface. If you are not familiar with the operator interface, please read the detailed descriptions of the front panel keys, indicators, and displays in Chapter 3 of this manual before beginning the procedures.

1. Check the coil balance using the procedure in Correcting Coil Imbalance on page 4-4.
2. Place the TMD in Setup mode.
3. Scroll to the BELT SPD display.

The counter should show the maximum belt speed or the actual speed if a speed sensor is being used. If the value is incorrect, change it.

4. Scroll to the BAR LEN display.

The counter should show the maximum bar/rod length for the TMD to detect. If the value is incorrect, change it.

5. Scroll to the BAR SENS display.

If the value in the counter is 0, bar/rod detection is disabled. Set the value to 1.

6. If the desired size bar/rod is not detected, increase the sensitivity value by 1 until it is.

Installing Default Values

If the TMD software should become corrupted, you may need to install the factory default values to get your system running. If possible, record all of your setup and calibration settings so you can re-enter them.

Follow this procedure to install factory default values.

1. Turn off power to the control unit (SW6).
2. Set DIP Switch position 8 on SW1 to ON (enable cold start on power up).

Refer to DIP Switch Settings on page 2-12.

- Turn on power to the control unit (SW6) and wait 4 seconds.

Default values will be installed on power up.

- Set DIP Switch position 8 on SW1 back to OFF.

Note: It is very important that you set the DIP Switch to OFF so you do not accidentally install default values if the machine is power cycled.

The factory default values are as follows:

PARAMETER	DEFAULT VALUE
Setup Displays	
CLIP DLY	00.0
BAR SENS	00.0
BAR LEN	01.0
BELT SPD	400
TIME DLY	00.1
TIME DUR	00.1
MAT CODE	003
FILTER	001
OP FREQ	000
REMOTE	N
MODBUS	N
Calibrate Displays	
COARSE	006
FINE	750
CLP CORS	000
CLP FINE	750

Error Messages

The TMD has built-in error detecting that recognizes and reports error and fault conditions in the system.

Error Conditions

When an error occurs, the ALARM LED lights and the error message appears on the display. The display shows the type of error that occurred (refer to Table 4 1). The counter shows the corresponding

error number. An E in the first digit of the counter indicates an error rather than a fault condition.

To clear an error message from the Run screen, press the ENTER key. Correct the error condition, scroll to the error message display (the last display in the scroll), and press ENTER to clear the message.

NO.	MESSAGE	MEANING
E1	COLD ST	The detector cold started on power up. Default values were used for calibration settings. Possible causes: Table Cold start DIP Switch is set to ON Table Memory problem
E2	RESETDIS	The reset disable input is open. (This input is used for the optional marker feature.) You cannot reset the detector until the input is closed by resetting the marker. (This prevents you from restarting the belt without the marker in place.)

Table 4–1. Error Messages

Fault Conditions

Faults indicate that the TMD found a failure in the electronics or a setting that does not allow the detector to operate. When a fault occurs, the ALARM LED lights and the alarm output relay is activated. If the TMD is in Run mode, the fault message appears on the display.

The display shows the type of fault that occurred (refer to Table 4-2). The counter shows the corresponding fault number. An F in the first digit of the counter indicates a fault rather than an error condition.

To clear a fault message from the Run screen, press the ENTER key. Correct the fault condition, scroll to the error message display (the last display in the scroll), and press ENTER to clear the message. To return the TMD to Run mode, scroll up to the Run screen.

NO.	MESSAGE	MEANING
F1	XMIT FLT	Indicates an open or short circuit has been detected in the transmitter coil. May be due to faulty wiring or actual fault condition.
F2	SELFTEST	Indicates a microprocessor problem.
F3	BALANCE	The coil imbalance exceeds the ability of the detector to electronically “self-balance.” See section 4.4.1
F4	HIGHPILE	The high pile input was not reset within 4 seconds after tripping.
F5	OVERLOAD	The input circuitry is saturated. Reduce gain, mechanically balance coils per 4.4.1 or remove the cause of the overload.
F6	EST	Not yet implemented.

Table 4–2. Fault Messages

Chapter 5 Service, Repair, & Replacement Parts

This chapter provides information about service, repair, and replacement parts for your ORETRONIC III TMD. It includes the telephone numbers for various departments at Thermo Scientific. The procedure for ordering replacement parts and a Return Material Authorization form are also included in this chapter.

Service and Repair Information

The maintenance information in this manual is designed to meet your service needs. If you should encounter a problem that requires technical assistance, you may call Thermo Scientific Product Service at (800) 445-3503.

Thermo Scientific also provides on-site service technicians to assist customers with installation, set up, initial calibration, customer training, maintenance, and repair. Contact the Field Service department at the number given below for current rates and scheduling.

Thermo Scientific has a repair center located at our plant in Minneapolis, Minnesota. Products that need system checkout or repair can be returned to the plant with the Return Material Authorization (RMA) form found on page 5-4. Contact our Repair and Returns department at (800) 445-3503 to get an RMA number to use on the form.

Note: Have your machine model number and serial number available when you call.

Main Switchboard	(763) 783-2500
FAX	(763) 783-2525
Technical Assistance	(800) 445-3503
Field Service	(800) 445-3503
Return Material Authorization & Repair	(800) 445-3503

Parts Ordering Information

For the fastest service when ordering parts, telephone or FAX the Thermo Scientific Parts Department at the numbers given below. Your regional field service representative can also assist you with parts orders, but this may delay shipment of your parts.

The recommended procedure for ordering parts is:

1. Determine the broken or faulty part.
2. Locate the part on the engineering drawings in Appendix D.
3. Find the corresponding part number in the parts list.
4. Before you contact Thermo Scientific for your parts, make sure you have the following information:
 - Machine model and serial number
 - Purchase Order number
 - Date required
 - Preferred shipping method
 - Part number(s), description, and quantity needed
5. Telephone or FAX:

Thermo Fisher Scientific
Customer Service Department
501 90th Ave. NW
Minneapolis, MN 55433
PHONE (800) 445-3503
FAX: (763) 783-2525

Business hours are 8:00 a.m. to 4:30 p.m. Central Time.

Parts Lists

The list below provides part numbers and descriptions of the replaceable parts for the Oretronic III TMD control unit.

All other replaceable parts for the Oretronic III TMD are shown on the engineering drawings in Appendix D. The drawings help you accurately identify the part(s) you need, and the parts lists on the drawings provide part numbers and descriptions.

ITEM DESCRIPTION	PART NO.
Control Unit Enclosure, NEMA 4X	060095
Chassis Assembly	067169
PCBA, CPU	058550
PCBA, Display	058547
Relays (6) GP, 24 V DC, 5 A, 2SPST, PC	049637
Fuse, SloBlo, .37 (3/8) A (1/4 x 1 1/4 Type T)	027784
Fuse, Slo-Blo, .19 (3/16) A (1/4 x 1 1/4 Type T)	022898
Transformer, Power	059782

Dear Customer,

Thank you for using our in-house repair service. To expedite your repair, control costs, and ensure that safety requirements are met please follow these simple steps.

1. Send in a copy of this completed form with a copy of your PO to the fax or email listed above. An RMA will not be issued without a hard copy PO on file.
2. Once an RMA has been issued, you will be sent a shipping label noting your RMA number and the address to ship the parts back to. The assigned RMA number is valid for 30 days from the date of issuance. If your part(s) is not received within 30 days, your PO will be cancelled and a new RMA will be required. All parts for repair MUST reference a valid RMA number or the part will be returned at your cost.
3. Please do not ship partial shipments. Your return must be complete. Any parts received separately will require a separate RMA and PO. Return only those products which are authorized by the RMA. Additional products that are sent without approval may be returned to you.
4. If a product is determined to be a "no defect found" then an evaluation fee of \$250.00 per part (\$500.00 per full system) sent in will be charged.

Thank you for giving Thermo Fisher Scientific the opportunity to satisfy your service needs. You can contact me by sending an e-mail to _____ or by calling 1-800-445-3503.

Return Material Authorization (RMA) Form

Note: Thermo Fisher Scientific safety policy requires a decontamination form for any package being received into our building. Please complete the following paperwork and send it to the fax or email noted above. Failure to do so will cause delays. If the unit is not decontaminated as required, there will be a \$300.00 minimum charge.

CONTACT INFORMATION

Contact Name: _____
Phone Number: _____
Fax Number: _____
Email: _____

SHIPPING INFORMATION

Company Name: _____
Address: _____
City: _____ State: _____ Zip: _____

BILLING INFORMATION (If different from above):

Company Name: _____
Address: _____
City: _____ State: _____ Zip: _____
A/P Contact Name: _____
Phone Number: _____
Fax Number: _____
Email: _____

TAX EXEMPT: Yes No

PAYMENT INFORMATION (Choose One):

Credit Card (If you wish to pay via credit card, please call 800-227-8891, opt.2. In order to protect our customers from accidental data compromise, Thermo Fisher Scientific dba Thermo Ramsey Inc does not accept credit card numbers via email or fax.)

Purchase Order (If you wish to pay via PO, please send an official hard copy PO with this form)
PO Number: _____

Warranty (All warranties need to be pre-approved by our tech support representatives prior to an RMA being issued. If this box is checked then a tech support rep will be contacting you shortly)

PRODUCT INFORMATION:

Part number: _____

Part Description: _____

Problem description:

Part number: _____

Part Description: _____

Problem description:

Part number: _____

Part Description: _____

Problem description:

Part number: _____

Part Description: _____

Problem description:

Part number: _____

Part Description: _____

Problem description:

DECONTAMINATION FORM

Please complete all areas of the Decontamination Declaration below.

- Orders without a Decontamination Declaration will not be processed and the instrument will be returned to the sender via collect freight.
- Please send this form with a hard copy of your PO to the above email or fax number to obtain an RMA number for shipping. Retain a copy for your records.

Please provide a specific description of your system's use:

Describe type of product run on your equipment:

Please describe all cleaning and/or decontamination performed:

Check all that apply:

- Out of Box Failure Non-Hazardous Materials only **Hazardous Material** (See Below)

Hazardous Materials:

<input type="checkbox"/> Carcinogen	<input type="checkbox"/> Bacteria	<input type="checkbox"/> Fungus	<input type="checkbox"/> Pathogen	<input type="checkbox"/> Toxic Substance
<input type="checkbox"/> Radioactive	<input type="checkbox"/> Virus	<input type="checkbox"/> Corrosive Chem. Hazard	<input type="checkbox"/> Flammable Chem. Hazard	<input type="checkbox"/> Reactive Chem. Hazard
<input type="checkbox"/> Animal/ Plant/ Mineral (Explain) _____ _____			<input type="checkbox"/> Other (Explain) _____ _____	

To the best of my knowledge, this equipment is free of harmful or hazardous chemical, biological or radioactive contamination. I understand that if the equipment is found to be contaminated, regardless of the signature on this document, the equipment will be returned at my company's expense.

Signature: _____ Title: _____ Date: _____

Disposal of Hazardous Waste

All soldered printed circuit boards must be disposed of in accordance with your local Hazardous Waste policy.

As an alternative, you may return product supplied by Thermo Scientific, with an RMA form, freight prepaid for disposal. Contact our Repair and Returns department at (800) 445-3503 to get an RMA number to use on the form.

Appendix A - TMD Modbus Interface

This Appendix provides information about the Modbus protocol implemented for communications between the ORETRONIC III Tramp Metal Detector (TMD) and an intelligent host or PLC. It deals only with the protocol as used for this particular interface.

If you need detailed information about all aspects of Modbus protocol, refer to Modicon, Document Number PI-MBUS-300, Revision J.

Overview of TMD Communications

The TMD Modbus interface protocol is a subset of the Modicon Modbus protocol. The physical layer uses an asynchronous serial bus topology with an RS-485 physical data medium. Transferred data is 8-bit binary using RTU framing and 16-bit CRC error checking.

Control is restricted to a single master/multiple slave configuration. The host or PLC must act as a Modbus master device. Baud rates supported are: 1200, 2400, 4800, 9600, 19200. The default is 9600 bps.

Modbus Message Types Supported by the TMD

The TMD provides normal Modbus responses only for the functions listed below; all other functions and diagnostic requests will return Exception 01 (Illegal Function).

- Function 03 - Read Holding Registers
- Function 06 - Preset Single Register
- Function 16 - Preset Multiple Registers

Holding register reads (Function 03) are restricted to transferring 1 to 16 registers at a time, starting with the specified holding register address. Any other form of holding register address will return Exception 02 (Illegal Data Address). This is a sub-set of normal Modbus slave responses.

Holding register writes (Function 16) are restricted to transferring 1 to 16 registers at a time, starting with the specified holding register address. Any other form of holding register address will return Exception 02

(Illegal Data Address). This is a sub-set of normal Modbus slave responses.

Broadcast messages are not supported in this implementation. Following are examples of Modbus query messages and their responses.

Example: Read Holding Registers

In this example, the host reads holding registers 40003–4005 from slave device 5.

QUERY		RESPONSE	
Field Name	Contents (Hex)	Field Name	Contents (Hex)
Slave Address	05	Slave Address	05
Function	03	Function	03
Starting Address Hi	00	Byte Count	06
Starting Address Lo	02	Data Hi (Reg. 40003)	02
No. of Registers Hi	00	Data Lo (Reg. 40003)	2B
No. of Registers Lo	03	Data Hi (Reg. 40004)	00
Error Check (16-bit CRC)		Data Lo (Reg. 40004)	00
		Data Hi (Reg. 40005)	00
		Data Lo (Reg. 40005)	64
		Error Check (16-bit CRC)	

Example: Preset Multiple Registers

In this example, the host writes new data (00 0A and 01 02 hex) to holding registers 40002–40003 in slave device 7.

QUERY		RESPONSE	
Field Name	Contents (Hex)	Field Name	Contents (Hex)
Slave Address	07	Slave Address	07
Function	10	Function	10
Starting Address Hi	00	Starting Address Hi	00
Starting Address Lo	01	Starting Address Lo	01
No. of Registers Hi	00	No. of Registers Hi	00
No. of Registers Lo	02	No. of Registers Lo	02
Byte Count	04	Error Check (16-bit CRC)	
Data Hi	00		
Data Lo	0A		
Data Hi	01		
Data Lo	02		
Error Check (16-bit CRC)			

Exception Responses

When the TMD is unable to respond normally to a Modbus query, it will return an appropriate exception response to the host.

Table A-1 shows the two-digit code and the meaning of each exception response.

EXCEPTION	CODE	MEANING
Illegal Function	01	The function code received in the query is not supported.
Illegal Data Address	02	The data address in the query is not an allowable value for the slave.
Illegal Data Value	03	The value in the query data field is not an allowable value for the slave.
Slave Device Busy	04	The slave is processing a long-duration program command.

Table A-1. TMD Exception Responses

Master/Slave Timing Considerations

The Modicon Modbus protocol establishes a minimum timing interval between query and response messages that use RTU framing. This delay allows devices attached to the serial bus to identify message boundaries by means of the idle time between messages. The minimum idle time between messages is 3.5 character times at the current serial baud rate. However, there must be no more than 1.5 character times between characters within a message, or the message will be considered invalid.

In a multidrop system, all slave devices must process all query messages, except for broadcast messages. Slave devices not addressed by the query must also process and discard the response message sent by the slave device that was addressed.

The slave device ID (slave address) for each individual TMD is assigned in setup and can be from 1 to 247. On a multidrop line, each address must be unique.

TMD Holding Registers

The TMD uses Modbus holding registers (4xxxx designation) to implement the register set. The message function code implicitly defines that the query applies to a holding register. The leading 4 (indicating a holding register) is not sent as part of the register address. Registers are addressed starting at zero: register 1 is addressed as 0.

Table A-2 describes each holding register used for Modbus communication with the TMD. In the table, Type “I” is a signed integer; Type “P” means that data is packed within the bytes. MSB = most significant byte, LSB = least significant byte.

REGISTER ADDRESS	ACCESS	TYPE	DESCRIPTION
40001	Read Only	I	Coast count = Number of pieces of metal counted since the last time the detector was RESET .
40002	Read Only	I	Total count = Total number of pieces of metal detected.
40003	Read Only	I	Received signal = Amplified and filtered signal derived from the receiver coil. The metal detection algorithm depends on the amplitude of this signal.
40004	Read/Write	I	Fine sensitivity used to determine whether metal is present.
40005	Read/Write	I	Clip sensitivity used to determine whether metal is present when clip detection is active.
40006	Read/Write	I	Clip delay = Length of belt to let pass the detection area when clip detection is active.
40008	Read/Write	I	Bar length = Maximum length of the bar/rod.
40009	Read/Write	I	Belt speed = Entered belt speed if no speed input is present. It is the actual belt speed if a speed sensor is present. The units are feet/minute or meters/minute, depending on the units implied by the operator during automatic calibration.
40010	Read/Write	I	Timed delay in seconds. The number stored in this register is divided by 10.
40011	Read/Write	I	Timed duration in seconds. The number stored in this register is divided by 10.
40012	Read/Write	I	Material code = Code ranging from 0 to 7 used to select the window timing that controls the time delay from the coil excitation phase to the data sampling phase. 0 - Minimum delay 7 - Maximum delay
40013	Read/Write	I	Coarse sensitivity = Amount of amplification applied to the signal from the receiver coil. 0 - Minimum gain 7 - Maximum gain
40014	Read/Write	I	Clip sensitivity = Amount of amplification applied to the signal from the receiver coil when clip detection is active. 0 - Minimum gain 7 - Maximum gain
40015	Read/Write	1	Key input register; shows which key was pressed. This register is used for diagnostic purposes. <ul style="list-style-type: none"> • 0xFF – No key was pressed • 0xFE – SCROLL up key was pressed

REGISTER ADDRESS	ACCESS	TYPE	DESCRIPTION
			0xFF - No key was pressed 0xFE - SCROLL up key was pressed 0xFD - RESET key was pressed 0xFB - VALUE up key was pressed 0xF7 - VALUE down key was pressed 0xEF - SCROLL down key was pressed • 0xDF – ENTER enter key was pressed
40016	Read Only	I	<i>THERMO FISHER SCIENTIFIC</i> USE ONLY
40017	Read Only	I	<i>THERMO FISHER SCIENTIFIC</i> USE ONLY
40018	Read Only	I	Password = Password entered by the user if password protection is enabled.
40019	Read Only	I	<i>THERMO FISHER SCIENTIFIC</i> USE ONLY
40020	Read Only	P	MSB = 0x20 (ASCII code for a space) LSB = ASCII code for character 0 (left most character) of the text display
40021	Read Only	P	MSB = 0x20 (ASCII code for a space) LSB = ASCII code for character 1 of the text display
40022	Read Only	P	MSB = 0x20 (ASCII code for a space) LSB = ASCII code for character 2 of the text display
40023	Read Only	P	MSB = 0x20 (ASCII code for a space) LSB = ASCII code for character 3 of the text display
40024	Read Only	P	MSB = 0x20 (ASCII code for a space) LSB = ASCII code for character 4 of the text display
40025	Read Only	P	MSB = 0x20 (ASCII code for a space) LSB = ASCII code for character 5 of the text display
40026	Read Only	P	MSB = 0x20 (ASCII code for a space) LSB = ASCII code for character 6 of the text display
40027	Read Only	P	MSB = 0x20 (ASCII code for a space) LSB = ASCII code for character 7 (right most character) of the text display
40028	Read Only	P	<i>THERMO FISHER SCIENTIFIC</i> USE ONLY
40029	Read Only	P	<i>THERMO FISHER SCIENTIFIC</i> USE ONLY
40030	Read Only	P	<i>THERMO FISHER SCIENTIFIC</i> USE ONLY

REGISTER ADDRESS	ACCESS	TYPE	DESCRIPTION
40046	Read Only	P	<p>Second general purpose status register, which is used for diagnostic purposes.</p> <p>If set (1), the bits have the following meanings (otherwise, bits are 0):</p> <ul style="list-style-type: none"> Bit 0 - Remote mode is enabled Bit 1 - Modbus is enabled Bit 2 - TMD is in Setup/Calibration mode Bit 3 - Speed input is enabled Bit 4 - SYNC input is enabled Bit 5 - Belt direction is set to "Reversed" Bit 6 - Measure units are Metric Bits 7–15 - Unused
40047–40099			Not used
40100	Read Only		<i>THERMO FISHER SCIENTIFIC USE ONLY</i>
40101	Read Only		<i>THERMO FISHER SCIENTIFIC USE ONLY</i>
40031	Read Only	P	<p>General-purpose status register, which is used for diagnostic purposes.</p> <p>If set (1), the bits have the following meanings (otherwise, bits are 0):</p> <ul style="list-style-type: none"> Bit 0 – NORMAL LED is on Bit 1 – ALARM LED is on Bit 2 – CALIB LED is on Bit 3 – BYPASS LED is on Bit 5 – Metal has been detected Bit 6 – An error has been detected Bit 7 – E1 error flag (Cold Start) is present Bit 8 – E2 error flag (Reset Disable) is present Bit 9 – F1 fault flag (Transmitter Coil) is present Bit 10 – F2 fault flag (Self Test) is present Bit 11 – F3 fault flag (Coil Balance) is present Bit 12 – F4 fault flag (High Pile) is present Bit 13 – F5 fault flag (A/D Converter Overload) is present Bit 14 – F6 fault flag (Audit Check Failure) is present Bit 15 – Not used

REGISTER ADDRESS	ACCESS	TYPE	DESCRIPTION
40032	Read Only	P	<p>Indicates how many LEDs are lit on the bar graph.</p> <p>Uni-polar mode:</p> <p>MSB = 0x00</p> <p>LSB = Number of LED bars lit</p> <p>In this mode, zero is at the bottom of the graph. LSB is proportional to the absolute value of the metal signal.</p> <p>Example: LSB = 3 indicates that three bars above the bottom are lit. This can mean +3 or -3.</p> <p>Bi-polar mode:</p> <p>MSB = 0x01</p> <p>LSB = Number of LED bars lit</p> <p>In this mode, zero is in the middle of the graph. LSB is proportional to the metal signal. Sign is taken into account.</p> <p>Example: LSB = 3 indicates that seven bars below the center are lit. This means -7.</p>
40033	Read/Write	I	Audit fine sensitivity if Audit Check is active.
40034	Read/Write	I	Audit coarse sensitivity if Audit Check is active.
40035	Read/Write	I	Audit interval = Time, in hours, between Audit Checks.
40036	Read/Write	I	<p>Filter = The noise filter used on the TMD.</p> <p>0 - Filter emphasizes middle of response curve</p> <p>1 - Filter emphasizes beginning of response curve</p> <p>2 - Filter weights all of the curve equally</p>
40037	Read/Write	I	<p>Frequency = The operating frequency of the TMD.</p> <p>0 - 900 Hz</p> <p>1 - 780 Hz</p> <p>2 - 660 Hz</p> <p>3 - 1020 Hz</p>
40038-40041	Read Only	P	<p>Software version, stored as two characters per integer.</p> <p>Left most character is stored in the MSB of Register 40038.</p>

REGISTER ADDRESS	ACCESS	TYPE	DESCRIPTION
40042–40044	Read Only	P	Packed ASCII representation of the 3-digit counter LED. Integer 0 - Left most digit (Reg. 40042) MSB = 0x20 (ASCII code for a space) LSB = ASCII code for left most digit Integer 1 - Middle digit (Reg. 40043) If left most digit has a decimal point: MSB = ASCII code for a . If left most digit does not have a decimal point: MSB = 0x20 (ASCII code for a space) LSB = ASCII code for middle digit Integer 2 - Right most digit (Reg. 40044) If middle digit has a decimal point: MSB = ASCII code for a . If middle digit does not have a decimal point: MSB = 0x20 (ASCII code for a space) LSB = ASCII code for right most digit
40045	Read Only	I	Time constant (in ms)

Appendix B - Remote Front Panel

This Appendix describes the optional remote front panel for the Oretronic III TMD. It includes technical specifications, wiring procedures, instructions for setup and operation, and a spare parts list.

Overview

The operator interface to the TMD is a front panel on the control unit. The front panel is composed of a touch panel keypad, LED indicators, an eight-character alphanumeric display, and a three-digit counter LED.

The keypad is used to enter and change values and to scroll the displays. The displays indicate tramp count and coast count during normal operations and are used during setup and calibration. LEDs visible from outside the enclosure indicate NORMAL, BYPASS, and ALARM conditions and a bar graph show signal strength.

A remote front panel display option using RS-485 serial communications can be added to the main TMD control unit. The remote front panel includes a separate power supply and has a distance limitation of 4,000 ft (1,219 m) from the main TMD control unit.

The remote front panel is identical to the front panel on the control unit in both appearance and operation.

Routine Maintenance

Keep the area around the TMD free from rocks and material build-up. The TMD system can be washed down with water and meets NEMA Type 4X standards. Do not add harsh chemicals, caustics, or disinfectants to the wash down solution.

The control unit enclosure can be wiped clean with a damp cloth, and if necessary, a mild detergent. Never use abrasive cleaners, especially on the display windows. Keep the enclosure door tightly closed to prevent dirt infiltration.

As a preventive measure, check all wires, plugs, and integrated circuits in the control unit to make sure they are tight in their connectors. The idlers on each side of the TMD coil support structure should be greased according to the manufacturer's specification.

Technical Specifications

Make sure that the conveyor belt is running true to the conveyor centerline in the detection area to prevent damage to the coil support structure and coil(s).

This section lists the technical specifications that pertain to the remote front panel of an Oretronic III Tramp Metal Detector.

Enclosure

Type:

NEMA 4X, non-metallic

Size:

11.20 in. x 9.23 in. x 6.12 in. (H x W x D)
(284.5 mm x 234.4 mm x 155.4 mm)

Weight:

11.5 lb (5.2 kg)

Maximum Distance from TMD:

4,000 ft (1,219 m)

Environmental Conditions

Location:

Indoor/outdoor

Storage Temperature:

-67° to 158° F (-55° to 7° C) ambient

Operating Temperature:

-40° to 122° F (-40° to 50° C)

Humidity:

10 to 95% relative humidity, non-condensing

Altitude:

6,561 ft (2,000 m)

Pollution Degree:

Pollution Degree 2

Power Requirements

Nominal Line Voltage:

115/230 VAC, selectable

Operating Range:

+10, -15%

Nominal Frequency:

50/60 Hz

Operating Range:

47-63 Hz

Fusing:

115 VAC (F1) - 1/4 A, 250 VAC, "Type T"

230 VAC (F1) - 1/8 A, 250 VAC, "Type T"

Maximum Non-Destructive Input Voltage:

150/300 VAC for one minute

Overvoltage Category:

Transient overvoltage according to installation category
(Overvoltage Category II)

Power Switch:

On chassis

Displays/Keypad

Display:

Three seven-segment LEDs for counts

One eight-character alphanumeric LED display

Bar Graph:

20 LED bars

Status LEDs:

Red for ALARM, green for NORMAL, yellow for BYPASS

Calibrate LED:

Indicates the detector is in calibrate mode

Keypad:

Mounted on the enclosure door

Cutouts for viewing display, status LEDs, and bar graph

Installing the Remote Front Panel

This section provides information about mounting and wiring the remote front panel.

Do not connect power to the machine or turn on the unit until you have read and understood this entire Appendix. The precautions and procedures presented in this Appendix must be followed carefully to prevent equipment damage and protect the operator from possible injury.



WARNING

Failure to follow safe installation and servicing procedures could result in death or serious injury.

- Make sure only qualified personnel perform installation and maintenance procedures in accordance with the instructions in this manual.
- Allow only qualified electricians to open and work in the electronics cabinets, power supply cabinets, control cabinets, or switch boxes.



WARNING

High voltage that may be present on leads could cause electrical shock.

- All switches must be OFF when checking input AC electrical connections, removing or inserting printed circuit boards, or attaching voltmeters to the system.
- Use extreme caution when testing in, on, or around the electronics cabinet, PC boards, or modules. There are voltages in excess of 115 V or 230 V in these areas.
- Covers over the electronics should always remain in place during operation. Remove only for maintenance procedures with the machine's power OFF. Replace all covers before resuming operation.



WARNING

Use only the procedures and new parts specifically referenced in this manual to ensure specification performance and certification compliance. Unauthorized procedures or parts can render the instrument dangerous to life, limb, or property.



WARNING

All wiring must be done in accordance with field wiring diagrams, applicable sections of the National Electrical Code, and local electrical codes.

Mounting the Remote Front Panel

The remote front panel should be mounted in a vibration-free area less than 4,000 ft (1,219 m) from the main TMD control unit. Mount the enclosure to a rigid, flat, vertical surface using the 2-position mounting feet on the back of the enclosure (see Figure B-1).

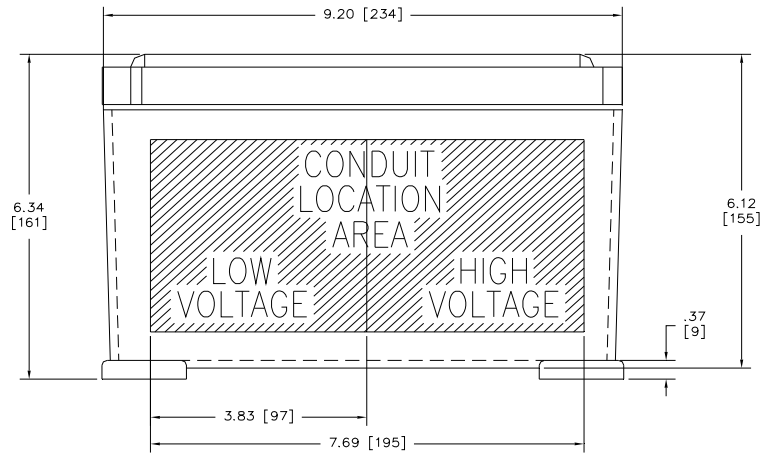
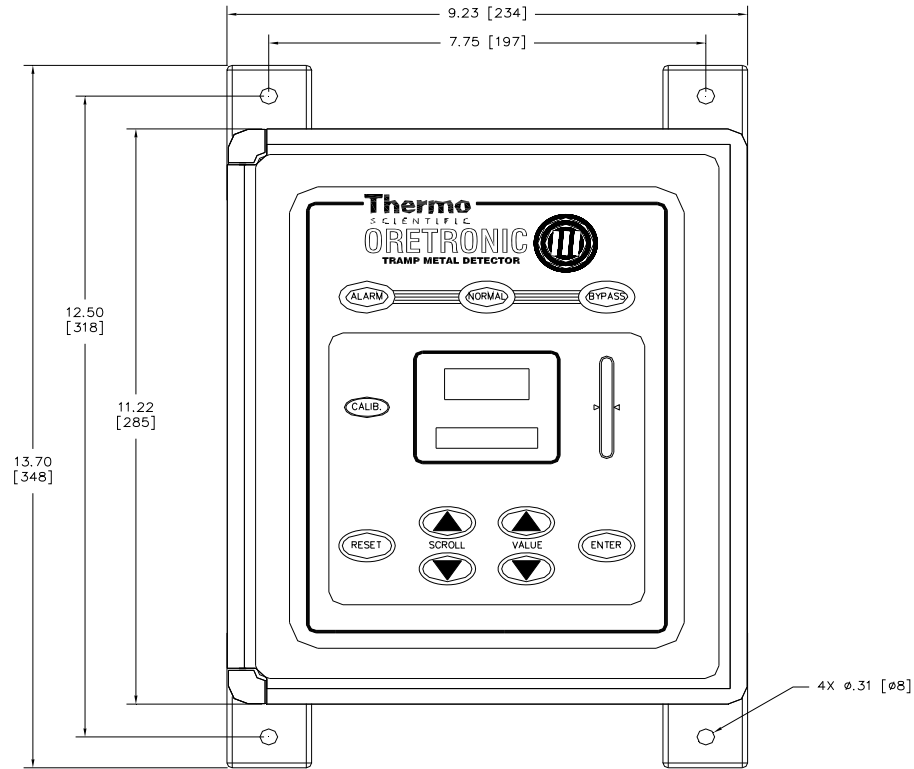

D07328C-B002

Figure B-1. Remote Front Panel Dimensions



WARNING

Make sure the mounting surface is flat so that the fibreglass enclosure does not twist or warp when the mounting bolts are tightened.

Follow this procedure to mount the remote front panel enclosure.

1. Open the enclosure door.
2. Bolt the enclosure to a flat, vertical surface using the 2-position mounting feet on the back of the enclosure (see Figure B-1).
3. Punch the required conduit holes in the bottom of the enclosure for the power supply cable and the communications cable(s).

Locate the holes on the appropriate sides of the enclosure to separate high and low voltages (see Figure B-1).

4. Install conduit.

Field Wiring the Remote Front Panel

All wiring, except as noted, is the responsibility of the customer. Follow the field wiring diagram for your system or refer to the Field Wiring Diagram (D07328C-E201) in Appendix D to connect system wiring to the remote front panel.



WARNING

All wiring must be done in accordance with field wiring diagrams, the National Electrical Code, and all local electrical codes.

Input Power Requirements

Switch selectable: 115 VAC or 230 VAC

Fusing: 115 VAC (F1) - 1/4 A, 250 VAC, "Type T"
 230 VAC (F1) - 1/8 A, 250 VAC, "Type T"

Critical Wiring Conditions

Be sure to observe the following critical wiring conditions to ensure proper connection of your detector:

- Ensure power to the remote front panel is OFF.
- Power and communications cables must be routed through different areas of the enclosure (see Figure B-1).
- Earth ground all enclosures and conduit. A ground connection between all conduits is required.

- Stranded, rather than solid, wire should be used. This wiring should be long enough, and routed, to allow the chassis to be removed from the front for servicing.
- Connect the shield only where shown.
- Never use a “megger” to check the wiring.
- A readily accessible disconnect device (maximum 20 A) shall be incorporated in the field wiring. This disconnect should be in easy reach of the operator and it must be marked as the disconnecting device for the equipment.
- All conduit should enter the bottom of the enclosure. Do not run conduit through the top or sides of the enclosure.

Field Wiring Procedure

Follow all cable number specifications on the Field Wiring Diagram (D07328C-E201) when connecting wiring to the remote front panel. Figure B-2 shows the locations of the wiring connections.



Figure B–2. Interior of the Remote Front Panel Enclosure

Use this procedure to wire the remote front panel.

1. Ensure that the POWER switch on the chassis cover is in the “OFF” position.

2. Route incoming power connections through a conduit hole in the bottom right of the enclosure (see Figure B-1). Use 14 AWG stranded copper wire.

Maintain a gap of at least ½ in. from low voltage wires.

Leave enough loose wiring (about 8 in.) to allow the chassis cover to be moved without having to disconnect wires.

3. Route the communications cable(s) through a conduit hole on the bottom left of the enclosure (see Figure B-1).

Leave enough loose wiring (about 8 in.) to allow the chassis cover to be moved without having to disconnect wires.

4. Connect the communications cables to the appropriate terminals on the remote front panel chassis cover (see Figure B-2). Refer to the Field Wiring Diagram (D07328C-E201). Connecting Incoming Power



WARNING

Do not apply power until you have read and understood this entire section. Improper connection may result in damage to your detector.

- Verify that the input voltage is correct with a voltmeter before you connect it to the unit. The red tag attached to the machine specifies the correct input voltage for your particular unit.
- Earth ground must be provided to the unit. Do not use conduit to provide this ground.
- Follow your local electrical codes and regulations for minimum wire size and routing.

Follow this procedure to connect incoming power to the remote front panel. See Figure B-2 for the locations of the terminals.

1. Determine the input power to be supplied to the control unit and set the VOLTAGE switch to the correct voltage (see Figure B-2).
2. Verify that fuse F1 is correct for the input power.

115 VAC = 1/4 A, 250 VAC, “Type T”

230 VAC = 1/8 A, 250 VAC, “Type T”

3. Connect the ground wire to the “GND” terminal.

4. Wire the HOT input power to the terminal labeled “H.”
 5. Wire the NEUTRAL input power to the terminal labeled “N.”
- Note:** Make sure the chassis cover is closed before applying power.
6. Put the POWER switch on the chassis cover in the “ON” position.

Setting the Comm Switches

There are four DIP Switches on the inside of the enclosure door that must be set correctly for the remote front panel. These switches correspond to the SW4 Comm switches on the CPU board of the main TMD.

The Comm switches must be set on both SW4 and the remote front panel. Refer to Table B-1 for the correct switch settings to support the remote front panel.

POS	FUNCTION	ON	OFF
1 & 2	Configures RS-485 communication.	2-wire RS-485	* 4-wire RS-485
3	Connects a termination resistor across the receive input.	* Termination ON	Termination OFF
4	Not used		

* Setting for TMD remote front

Table B-1. Comm Switch Settings

Setting up and Operating the Remote Front Panel

The remote front panel uses the setup and calibration parameter settings of the main TMD control unit. To support the remote front panel, the remote? parameter in the control unit must be set to y.

Because the operator interface provided by the remote front panel is identical to that provided by the TMD control unit, all operations are performed identically. Refer to Chapter 3 for a complete description of the operator interface and information about operations. Refer to Chapter 4 for information about troubleshooting procedures.

Note: If the main TMD control unit is in use, the display on the remote front panel will show busy if you try to use it. You will not be able to use the remote until 30 seconds after the control unit is no longer in use.

Parts List

The list below provides part numbers and descriptions of the replaceable parts for the ORETRONIC III TMD remote front panel.

Refer to the parts list in Chapter 5 and the engineering drawings in Appendix C for other TMD system part numbers. The drawings help you accurately identify the part(s) you need, and the parts lists on the drawings provide part numbers and descriptions.

ITEM DESCRIPTION	PART NO.
Enclosure, Rmt Display	060097
PCBA, Rmt Display/CPU	0654559
Fuse, Slo-Blo, 1/8 (.125) A (.25 x .125, Type T)	058550

Appendix C - Electronically Simulated Tramp (EST)

This appendix introduces you to Electronically Simulated Tramp (EST), a specially designed optional system for your TMD. EST works as a quality assurance check for your TMD to ensure the transmitter and receiver coils are operating properly.

Theory of Operation

The transmitter induces a magnetic field in the EST that is detected by the receiver coil. This effect is similar to what occurs when tramp metal is present.

EST is periodically enabled by a timer that can be scheduled from 1 to 24 hours. The TMD reads the induced field EST produces and tests it against a learned or reference EST value.

EST will not turn on when a belt splice is detected, but waits until the belt splice is through the coils and then starts the test.

If the latest EST value measured differs from the reference or learned EST value, an alarm is generated.

This simple, yet sophisticated system guarantees the transmitter and receiver on your TMD are working properly.

Mechanical Installation

Use the following procedures for mechanical, electrical installation, calibration, and setup. See Appendix D for the Engineering Drawings related to mechanical installation.

EST is mounted on the coil support crossbeams.

1. Loosen nuts and remove the bolts from the coil support cross beam.
2. Place the EST plate under the coil support cross beam.
3. Using the bolts provided, insert the bolts through the coil support cross beam and the slots in the EST plate. Place the nuts on the ends of the bolts and hand tighten.

Note: Do not tighten the bolts securely at this time.

Electrical Installation

See Appendix D for the engineering drawing related to electrical installation.

Calibration and Setup

1. At the TMD control panel, from the RUN menu, scroll to the CALIBRATION menu press the value up arrow until the display toggles to Y
2. Press ENTER
3. Scroll through the CALIBRATION menu until EST CAL displays.
4. Press ENTER

EST takes three readings; these reading are at an interval that is dependent on your belt speed. The system then takes an average of the three readings and displays it on the display screen.

5. The reading should display between 250 and 500. If your reading is below or above those values, you have to gently move EST horizontally to reposition it.
6. Press the ENTER key and run the calibration procedure again. Keep moving the EST and running the calibration until your reading displays in the desired 250-500 signal range.
7. After the value displays between 250 and 500, securely tighten the nuts on the bolts that run through the cross support beam and the EST plate.
8. Run the calibration again to ensure the EST plate did not move while tightening the nuts. If the reading is not between 250 and 500, loosen the nuts and start the calibration again beginning with Step 5.

Interval Setup

EST can be set to run at specific intervals. The interval range is between 1 and 24 hours. Use the following procedures to set up EST interval for automatic operation:

1. At the TMD control panel, from the RUN menu, scroll to the SETUP menu press the value up arrow until the display toggles to Y.

2. Press ENTER
3. Scroll through the SETUP menu until EST INT displays
4. Press ENTER

The current interval displays.

5. Use the arrow keys to set the designated interval time between 1 and 24 hours.

Note: When you set the calibration reading and the interval you must scroll back through the menus until you reach the RUN menu. If you do not scroll back to the RUN menu, your changes are not saved.

Last EST (EST Last)

Last EST (EST LAST) displays the last signal reading for the last interval EST test. Use the following procedures to display the last EST value:

1. At the TMD control panel, from the RUN menu, scroll to the CALIBRATION menu.
2. Press ENTER
3. Scroll through the CALIBRATION menu until EST LAST displays.
4. EST reading from the last interval time displays.

EST Test (EST Test)

EST Test (EST TEST) runs EST through a system test on demand. Use the following procedures to run an EST test:

1. At the TMD control panel, from the RUN menu, scroll to the CALIBRATION menu press the up arrow until the display toggles to Y.
2. Press ENTER
3. Scroll through the CALIBRATION menu until EST TEST displays.
4. Press ENTER

EST Test performs an EST test on demand. A test on demand can be done in either calculation or normal mode of operation.

An EST test done on demand in NORMAL operating mode is identical to an EST test done automatically using the EST Time Interval.

If the test fails, the ALARM LED lights and the alarm output is activated. The alarm must be cleared before returning to normal operation.

An EST test failure in the CALIBRATION mode only lights the ALARM LED. The ALARM LED turns off if either scroll key is pressed.

Use the following procedure to perform an EST Test in CALIBRATION mode:

1. At the TMD control panel, from the RUN menu, scroll to the CALIBRATION menu. Press the up arrow until the display toggles to Y.
2. Press ENTER
3. Scroll through the CALIBRATION menu until EST Test displays.
4. Press ENTER

Use the following procedures to perform an EST Test in NORMAL mode:

1. At the TMD control panel, from the RUN menu, scroll to the CALIBRATION menu. Press the up arrow until the display toggles to N.
2. Press ENTER
3. Scroll through the CALIBRATION menu until EST Test displays.
4. Press ENTER

Appendix D Engineering Drawings

This Appendix contains the engineering drawings for your Oretronic III Tramp Metal Detector system. The following drawings are included:

- Field Wiring Diagram
(D07344A-E001)
- Field Wiring Diagram
(D07344A-E002)
- Field Wiring Diagram
(D07344A-E031)
- Field Wiring Diagram
(D07344B-E010)
- Field Wiring Diagram
(D07344B-E012)
- Under Belt Single Coil Assembly Stand
(D07328C-A110-XX)
- Under Belt Single Coil Final Assembly
(D07328C-A101)
- Under Belt Single Coil Installation Placement
(D07328C-A102)
- Final Assembly, Standard System
(D07328C-A001)
- Installation Placement, Standard System
(D07328C-A002)

- Outline, Mounting and Assembly, Coil Stand
(D07328C-A003)
- Outline & Mounting Dimensions, Clip Detector
(C07328C-B003)
- Outline & Mounting Dimensions, Flag Drop Marker
(B07328C-B004)
- Outline & Mounting Dimensions, Spray Marker
(D07344B-B007)
- Outline & Mounting Dimensions, Alarm Horn
(B07328C-B005)
- Outline & Mounting dimensions, Rotating Beacon Assembly
(B07328C-B006)
- Outline, Mounting and Installation, High Pile Detector
(B07328C-B007)
- Electronically Simulated Tramp (EST) Assembly Standard/Hi
Strength
(D07328C-K001)
- EST Outline and Mounting
(D07328C-B008)
- EST Under Belt Outline and Mounting
(D07328C-B102)

ITEM	PART NO	QTY	DESCRIPTION	DWG NO/SPEC
------	---------	-----	-------------	-------------

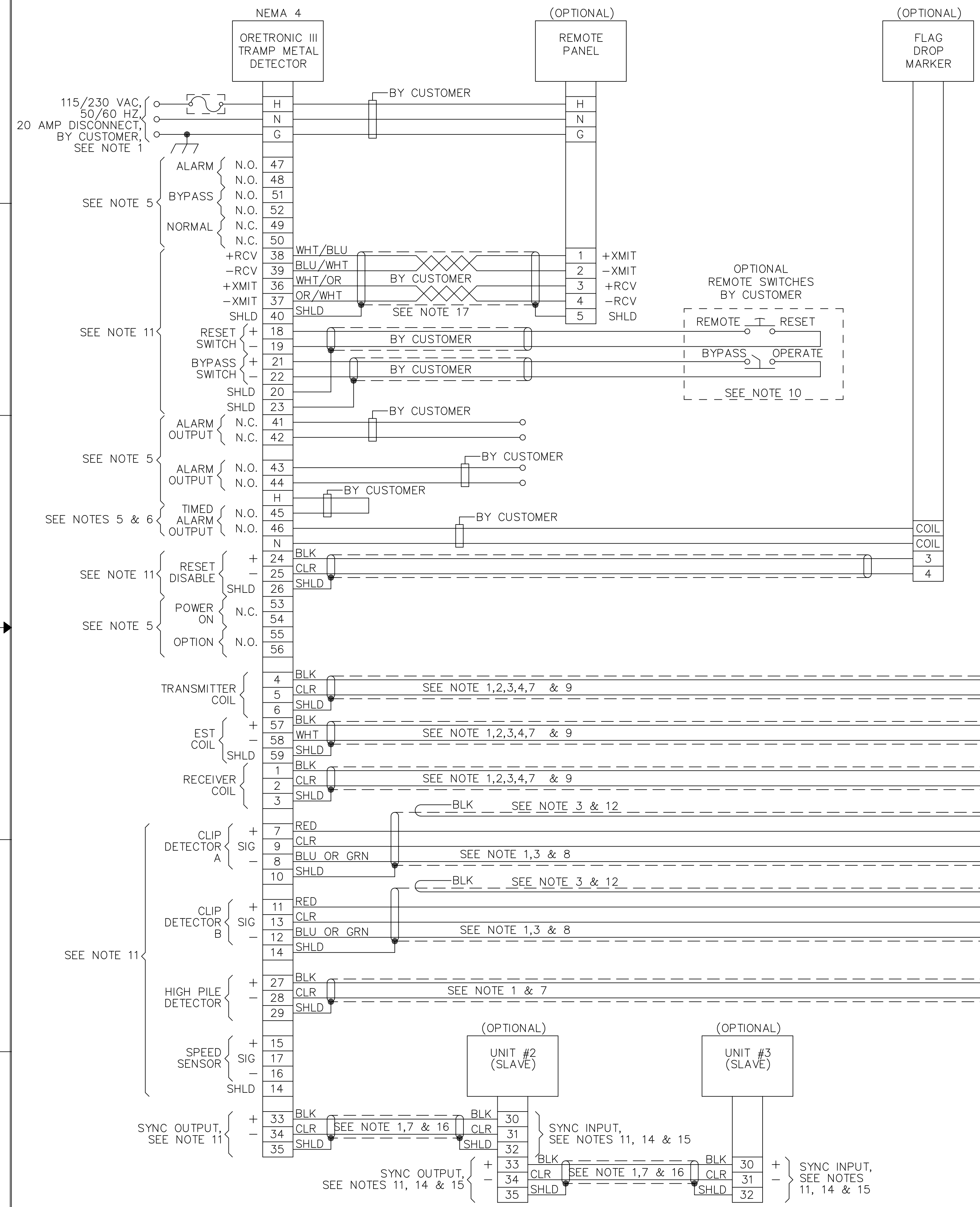

- NOTES:**
- ALL WIRING MUST BE IN ACCORDANCE WITH (A) INSTRUCTION MANUAL, (B) THIS DRAWING AND (C) THE NATIONAL ELECTRICAL CODE FOR AREA WHERE INSTALLED.
 - ALL COILS ARE TO BE POSITIONED SO THE CONTROL AND COIL CABLES ARE ON THE SAME SIDE OF THE CONVEYOR.
 - ADJUST TRANSMITTER COIL, RECEIVER COILS, EST COILS AND CLIP DETECTOR(S), PER INSTALLATION DRAWING.
 - IF BELT DIRECTION IS OPPOSITE OF THE BELT TRAVEL DIRECTION SHOWN ON THE COIL, REVERSE THE RECEIVER COIL BLACK AND CLEAR WIRES.
 - ISOLATED CONTACTS FOR ALARM PROCESS CONTROL ARE RATED 5 AMPS AT 250 VAC NON-INDUCTIVE. CONTACTS, EXCEPT FOR TIME ALARM OUTPUT, ARE SHOWN IN NORMAL OPERATION, POWER ON, ENERGIZED (FAIL SAFE) NO ALARM CONDITION. TERMINALS 47-50 MIMIC FRONT PANEL INDICATORS.
 - TIMED ALARM CONTACT IS NORMALLY OPEN, 0-10 SECOND DELAY ON CLOSURE AFTER TRAMP IS DETECTED, WITH A 0-1 SECOND ADJUSTABLE "ON" TIME. ADJUSTMENT IN .1 SECOND INCREMENTS.
 - USE BELDEN CABLE NUMBER 8760 OR EQUIVALENT FOR WIRING REMOTE RESET SWITCH, RESET DISABLE, HIGH PILE DETECTOR, BYPASS SWITCH, SYNC OUTPUT AND THE TRANSMITTER, RECEIVER AND EST COILS.
 - USE BELDEN CABLE NUMBER 8772 OR EQUIVALENT FOR CLIP DETECTOR WIRING.
 - DO NOT RUN COIL CABLES THROUGH THE SAME CONDUIT AS POWER OR CONTROL WIRING.
 - INTERNAL COMPONENTS SHOWN ONLY FOR CLARITY.
 - THESE INPUTS/OUTPUTS ARE LOW LEVEL D.C. ONLY: MAXIMUM RATINGS ARE 24 VDC AND 80mA.
 - BLACK WIRE FROM CLIP DETECTOR IS NOT USED. INSULATE BLACK WIRE WITH ELECTRICAL TAPE OR OTHER APPROPRIATE METHODS.
 - THE SYNC FEATURE MUST BE USED WHEN THE COILS OF TWO OR MORE TRAMP METAL DETECTORS ARE WITHIN 30 FEET OF EACH OTHER.
 - WHEN REQUIRED, CONTINUE WIRING OF MULTIPLE SLAVE TRAMP METAL DETECTORS USING THE SYNC FEATURE AS ILLUSTRATED.
 - MAXIMUM CABLE LENGTH FOR SYNC OUTPUT/INPUT IS 60 FEET.
 - ALL CABLES BY THERMO, EXCEPT AS NOTED.
 - USE BELDEN CABLE NUMBER 9829 FOR REMOTE PANEL WIRING. (MAX. 4000 FT)

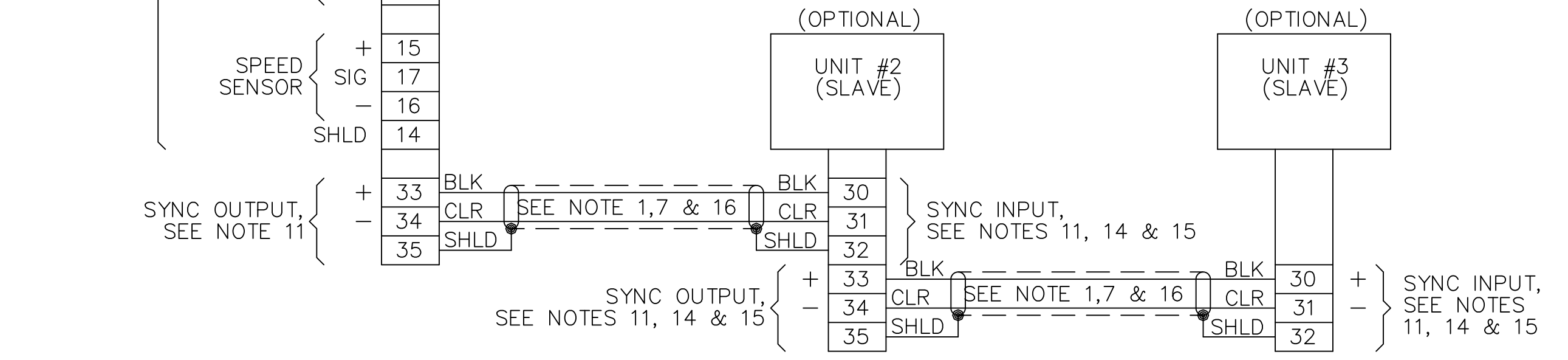
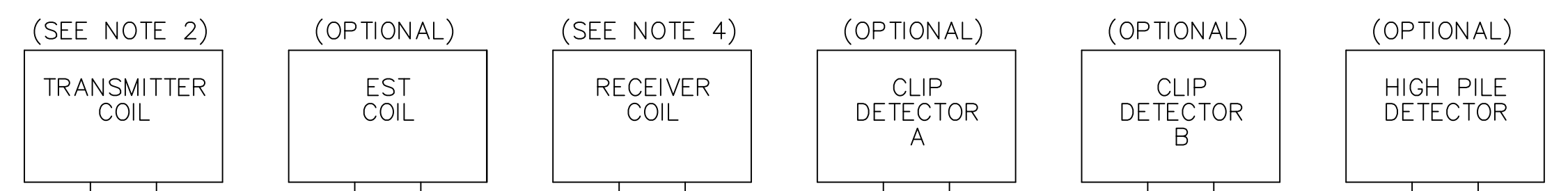

REV	ECO NO	MICRO	DESCRIPTION	DATE	BY	APPD
J	1293		20 AMP DISCONNECT WAS: 15 AMP	12/14/06	GDK	RWT
H	1194		ADDED CONTACT DETAILS AND REVISED NOTE 5	11/17/06	KIM	RWT
G	0660		FORMAT CHANGE	6/07/05	LB	RWT
F	3114		CHANGE NOTE 15	4/19/02	KIM	RWT
E	2768		CHANGE SPARE TO OPTON	8/8/01	KIM	RWT
D	2673		SPARE WAS AUDIT CHECK	5/10/01	KIM	RWT
C	2662		ADD EST OPTION	4/24/01	KIM	RWT
B	2461		CORRECT COMM LINK	11/30/00	KIM	RWT
A	2233		RELEASED	6/14/00	KIM	RWT

DO NOT SCALE DWG		SCALE	NONE
REMOVE ALL BURRS AND UNNECESSARY SHARP EDGES		JOB NO	
TOLERANCE UNLESS SPECIFIED		ENG RWT	DATE 2/15/00
± .06		OWN	DATE 2/15/00
± .03		CHK	DATE 6/14/00
± .01			
± 1/16			
± 1/2			
NEXT ASS'Y			
CUST ORDER NO			
CUSTOMER LOCATION			
USER LOCATION			

This document is confidential and is the property of Thermo Fisher Scientific. It may not be copied or reproduced in any way without the expressed written consent of Thermo Fisher Scientific. This document also is an unpublished work of Thermo Fisher Scientific. Thermo Fisher Scientific intends to and is maintaining the work as confidential information. Thermo Fisher Scientific also may seek to protect this work as an unpublished copyright. In the event of other independent or derivative publications, Thermo Fisher Scientific intends to enforce its right to this work under the copyright laws as a published work. Those having access to this work may not copy, use or disclose the information in this work unless expressly authorized by Thermo Fisher Scientific.

Thermo Fisher SCIENTIFIC

FIELD WIRING DIAGRAM
TRAMP METAL DETECTOR
ORETRONIC III
NEMA 4

PART NO	DRAWING NUMBER	REV
	D07344A-E001	J

ITEM	PART NO	QTY	DESCRIPTION	DWG NO/SPEC
------	---------	-----	-------------	-------------

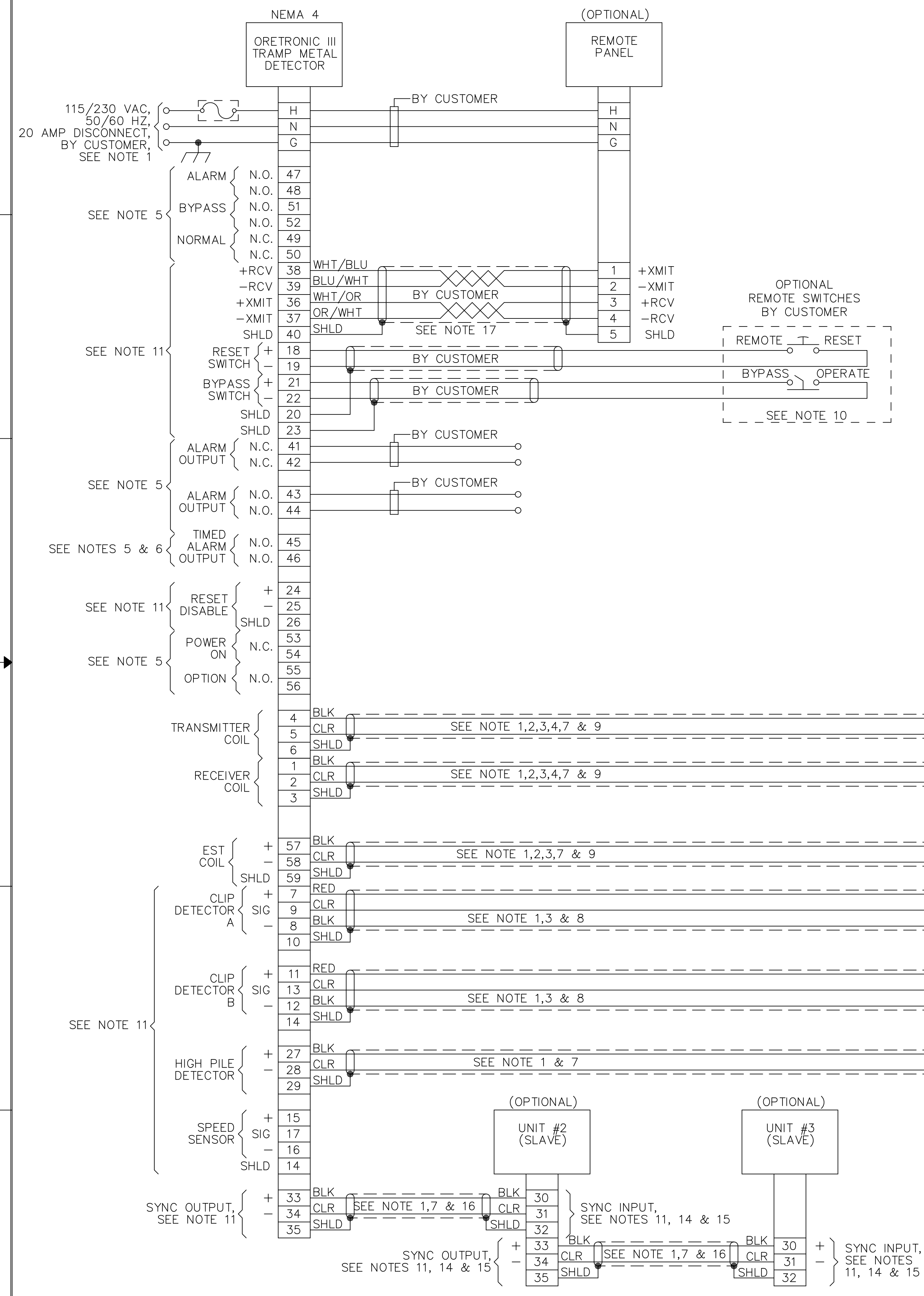

- NOTES:
- ALL WIRING MUST BE IN ACCORDANCE WITH (A) INSTRUCTION MANUAL, (B) THIS DRAWING AND (C) THE NATIONAL ELECTRICAL CODE FOR AREA WHERE INSTALLED.
 - ALL COILS ARE TO BE POSITIONED SO THE CONTROL AND COIL CABLES ARE ON THE SAME SIDE OF THE CONVEYOR.
 - ADJUST TRANSMITTER COIL, RECEIVER COILS, EST COILS AND CLIP DETECTOR(S), PER INSTALLATION DRAWING.
 - IF BELT DIRECTION IS OPPOSITE OF THE BELT TRAVEL DIRECTION SHOWN ON THE COIL, REVERSE THE RECEIVER COIL BLACK AND CLEAR WIRES.
 - ISOLATED CONTACTS FOR ALARM PROCESS CONTROL ARE RATED 5 AMPS AT 250 VAC NON-INDUCTIVE. CONTACTS, EXCEPT FOR TIME ALARM OUTPUT, ARE SHOWN IN NORMAL OPERATION, POWER ON, ENERGIZED (FAIL SAFE) NO ALARM CONDITION. TERMINALS 47-50 MIMIC FRONT PANEL INDICATORS.
 - TIMED ALARM CONTACT IS NORMALLY OPEN, 0-10 SECOND DELAY ON CLOSURE AFTER TRAMP IS DETECTED, WITH A 0-1 SECOND ADJUSTABLE "ON" TIME. ADJUSTMENT IN .1 SECOND INCREMENTS.
 - USE BELDEN CABLE NUMBER 8760 OR EQUIVALENT FOR WIRING REMOTE RESET SWITCH, RESET DISABLE, HIGH PILE DETECTOR, BYPASS SWITCH, SYNC OUTPUT AND THE TRANSMITTER, RECEIVER AND EST COILS.
 - USE BELDEN CABLE NUMBER 8772 OR EQUIVALENT FOR CLIP DETECTOR WIRING.
 - DO NOT RUN COIL CABLES THROUGH THE SAME CONDUIT AS POWER OR CONTROL WIRING.
 - INTERNAL COMPONENTS SHOWN ONLY FOR CLARITY.
 - THESE INPUTS/OUTPUTS ARE LOW LEVEL D.C. ONLY: MAXIMUM RATINGS ARE 24 VDC AND 80mA.
 - BLACK WIRE FROM CLIP DETECTOR IS NOT USED. INSULATE BLACK WIRE WITH ELECTRICAL TAPE OR OTHER APPROPRIATE METHODS.
 - THE SYNC FEATURE MUST BE USED WHEN THE COILS OF TWO OR MORE TRAMP METAL DETECTORS ARE WITHIN 30 FEET OF EACH OTHER.
 - WHEN REQUIRED, CONTINUE WIRING OF MULTIPLE SLAVE TRAMP METAL DETECTORS USING THE SYNC FEATURE AS ILLUSTRATED.
 - MAXIMUM CABLE LENGTH FOR SYNC OUTPUT/INPUT IS 60 FEET.
 - ALL CABLES BY THERMO, EXCEPT AS NOTED.
 - USE BELDEN CABLE NUMBER 9829 FOR REMOTE PANEL WIRING. (MAX. 4000 FT)

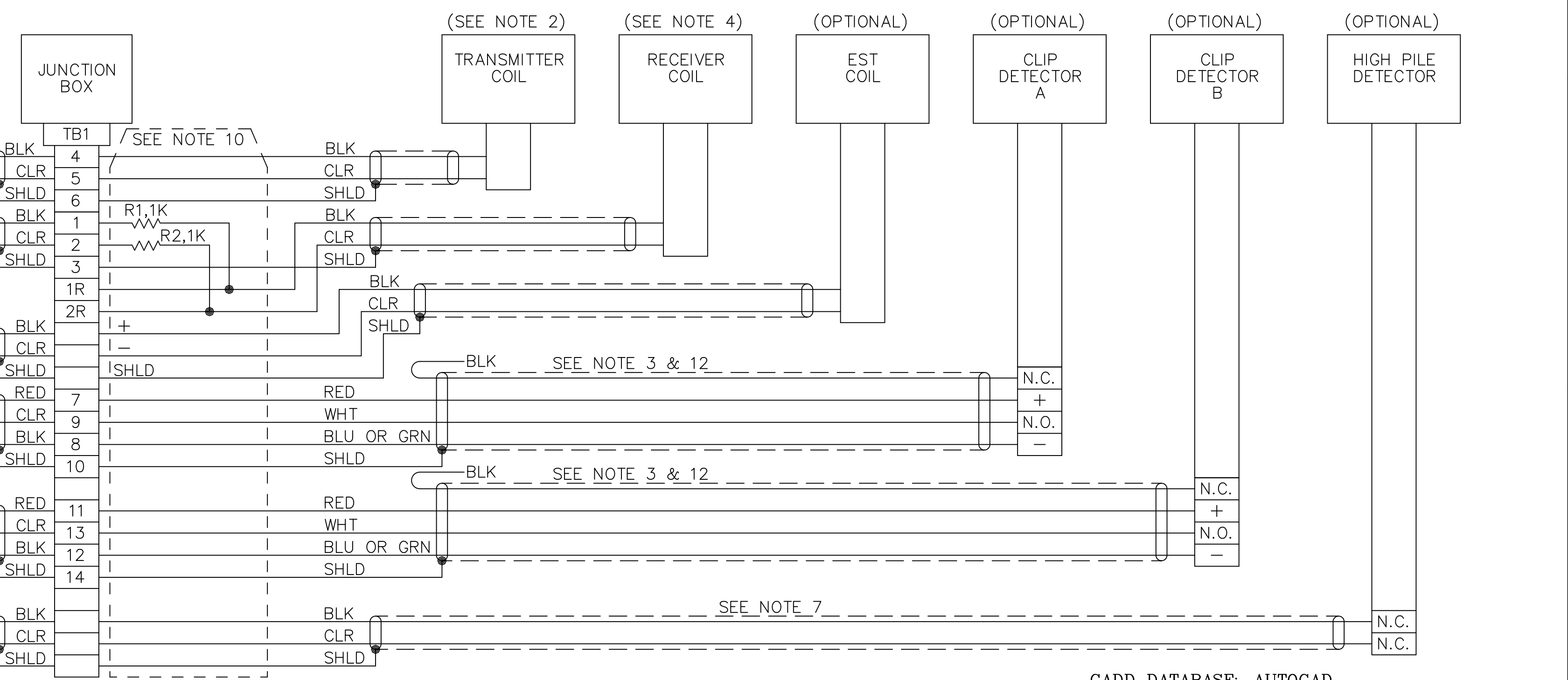

REV	ECO NO	MICRO	DESCRIPTION	DATE	BY	APPD
J	1293		20 AMP DISCONNECT WAS: 15 AMP	12/14/06	GDK	RWT
H	1194		ADDED CONTACT DETAILS AND REVISED NOTE 5	11/17/06	KIM	RWT
G	0660		FORMAT CHANGE	6/07/05	LB	RWT
F	3114		CHANGE NOTE 15	4/19/02	KIM	RWT
E	2768		CHG SPARE TO OPTION, ADD EST FROM JBOX TO TMD	8/9/01	KIM	RWT
D	2673		SPARE WAS AUDIT CHECK	5/11/01	KIM	RWT
C	2662		ADD EST OPTION	4/24/01	KIM	RWT
B	2461		CORRECT COMM LINK	11/30/00	KIM	RWT
A	2233		RELEASED	10/16/00	KIM	RWT

CADD DATABASE: AUTOCAD

DO NOT SCALE DWG
REMOVE ALL BURRS AND UNNECESSARY SHARP EDGES

SCALE: NONE
JOB NO: _____

TOLERANCE UNLESS SPECIFIED:
 .xx ± .06
 .xxx ± .03
 FRACT. ± .01
 ANGLES ± 1/16
 NEXT ASS'Y
 CUST ORDER NO

USER LOCATION: _____
 DRAWING NUMBER: D07344A-E002
 REV: J

Thermo Fisher Scientific
 FIELD WIRING DIAGRAM
 TRAMP METAL DETECTOR
 ORETRONIC III NEMA 4
 WITH J-BOX

© 2005 by Thermo Fisher Scientific

ITEM	PART NO	QTY	DESCRIPTION	DWG NO/SPEC
------	---------	-----	-------------	-------------

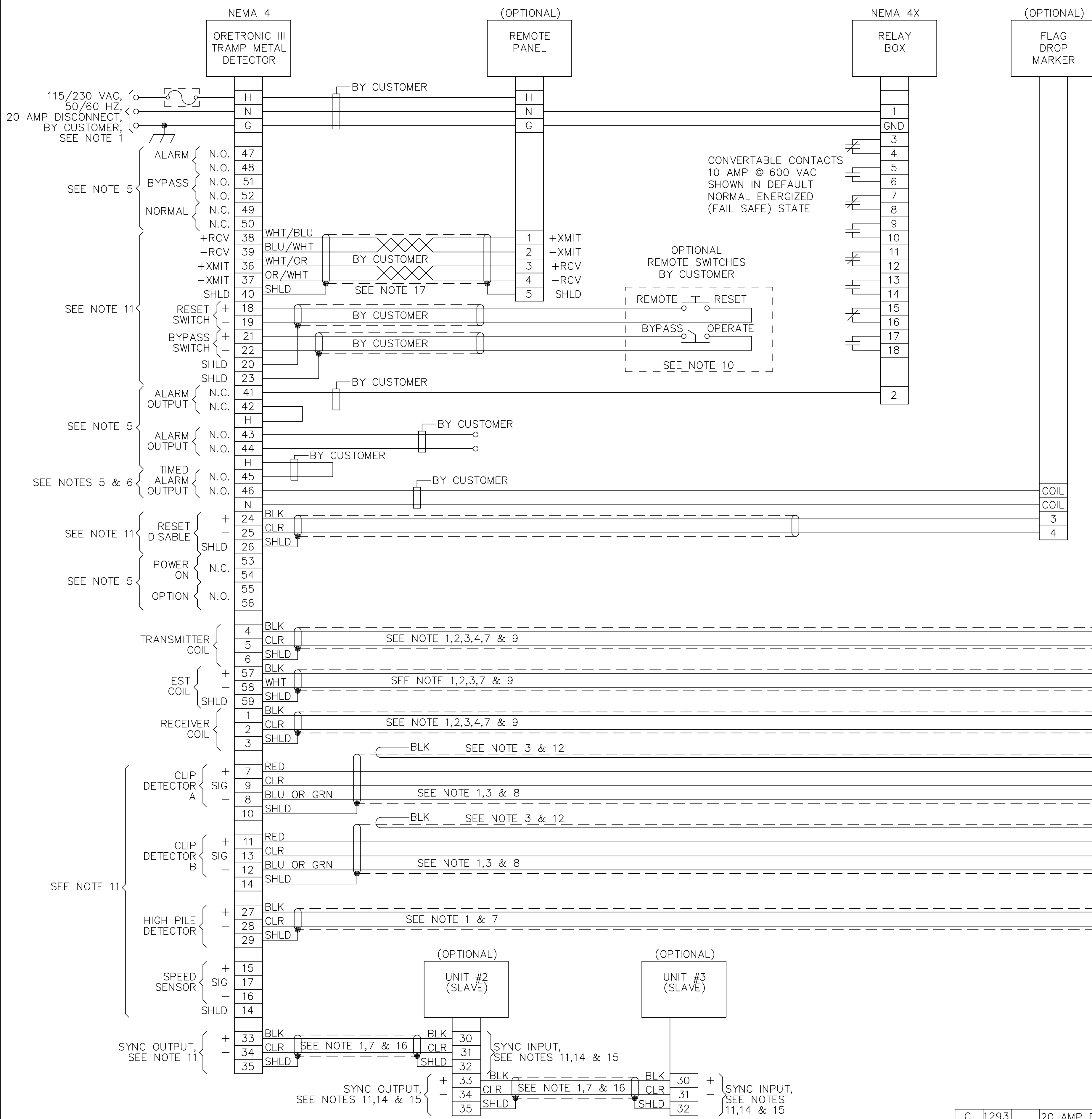

- NOTES:**
- ALL WIRING MUST BE IN ACCORDANCE WITH (A) INSTRUCTION MANUAL, (B) THIS DRAWING AND (C) THE NATIONAL ELECTRICAL CODE FOR AREA WHERE INSTALLED.
 - ALL COILS ARE TO BE POSITIONED SO THE CONTROL AND COIL CABLES ARE ON THE SAME SIDE OF THE CONVEYOR.
 - ADJUST TRANSMITTER COIL, RECEIVER COILS, EST COILS AND CLIP DETECTOR(S), PER INSTALLATION DRAWING.
 - IF BELT DIRECTION IS OPPOSITE OF THE BELT TRAVEL DIRECTION SHOWN ON THE COIL, REVERSE THE RECEIVER COIL BLACK AND CLEAR WIRES.
 - ISOLATED CONTACTS FOR ALARM PROCESS CONTROL ARE RATED 5 AMPS AT 250 VAC NON-INDUCTIVE. CONTACTS, EXCEPT FOR TIME ALARM OUTPUT, ARE SHOWN IN NORMAL OPERATION, POWER ON, ENERGIZED (FAIL SAFE) NO ALARM CONDITION. TERMINALS 47-50 MIMIC FRONT PANEL INDICATORS.
 - TIMED ALARM CONTACT IS NORMALLY OPEN, 0-10 SECOND DELAY ON CLOSURE AFTER TRAMP IS DETECTED, WITH A 0-1 SECOND ADJUSTABLE "ON" TIME. ADJUSTMENT IN .1 SECOND INCREMENTS.
 - USE BELDEN CABLE NUMBER 8760 OR EQUIVALENT FOR WIRING REMOTE RESET SWITCH, RESET DISABLE, HIGH PILE DETECTOR, BYPASS SWITCH, SYNC OUTPUT AND THE TRANSMITTER, RECEIVER AND EST COILS.
 - USE BELDEN CABLE NUMBER 8772 OR EQUIVALENT FOR CLIP DETECTOR WIRING.
 - DO NOT RUN COIL CABLES THROUGH THE SAME CONDUIT AS POWER OR CONTROL WIRING.
 - INTERNAL COMPONENTS SHOWN ONLY FOR CLARITY. 11. THESE INPUTS/OUTPUTS ARE LOW LEVEL D.C. ONLY: MAXIMUM RATINGS ARE 24 VDC AND 80mA.
 - BLACK WIRE FROM CLIP DETECTOR IS NOT USED. INSULATE BLACK WIRE WITH ELECTRICAL TAPE OR OTHER APPROPRIATE METHODS.
 - THE SYNC FEATURE MUST BE USED WHEN THE COILS OF TWO OR MORE TRAMP METAL DETECTORS ARE WITHIN 30 FEET OF EACH OTHER.
 - WHEN REQUIRED, CONTINUE WIRING OF MULTIPLE SLAVE TRAMP METAL DETECTORS USING THE SYNC FEATURE AS ILLUSTRATED.
 - MAXIMUM CABLE LENGTH FOR SYNC OUTPUT/INPUT IS 60 FEET.
 - ALL CABLES BY THERMO, EXCEPT AS NOTED.
 - USE BELDEN CABLE NUMBER 9829 FOR REMOTE PANEL WIRING. (MAX. 4000 FT)

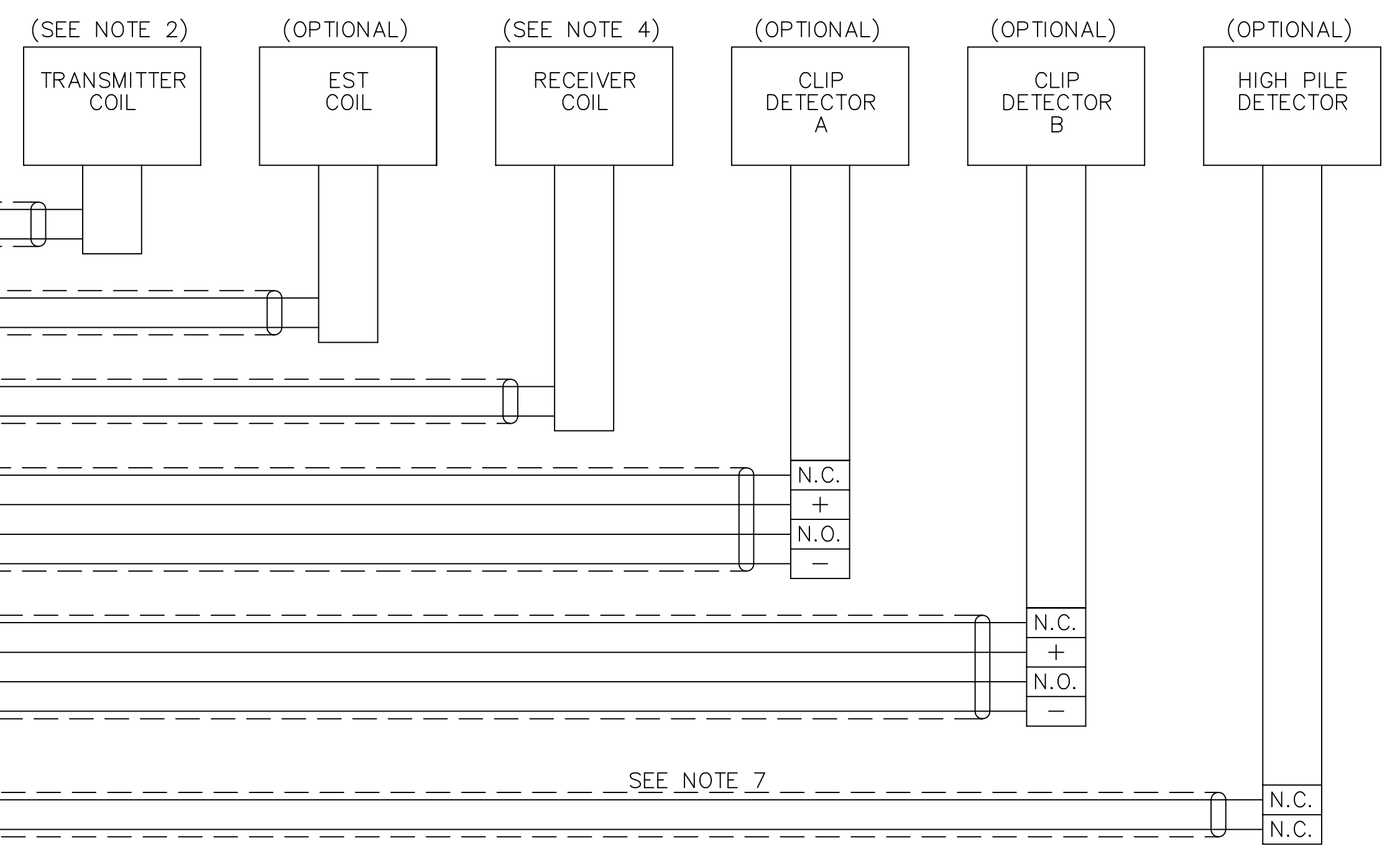

CADD DATABASE: AUTOCAD

DO NOT SCALE DWG SCALE NONE

REMOVE ALL BURRS AND UNNECESSARY SHARP EDGES JOB NO

TOLERANCE UNLESS SPECIFIED	ENG RWT	DATE
.x ± .06	OWN	2/23/05
.xx ± .03	LB	2/23/05
FRACT ± .01	CHK	DATE
ANGLES ± 1/16	RWT	2/23/05
± 1/2"		

NEXT ASS'Y

CUST ORDER NO

CUSTOMER LOCATION

USER LOCATION

FIELD WIRING DIAGRAM TRAMP METAL DETECTOR ORETRONIC III W/RELAY BOX NEMA 4

PART NO DRAWING NUMBER REV

D07344A-E031 C

REV	ECO NO	MICRO	DESCRIPTION	DATE	BY	APPD
C	1293		20 AMP DISCONNECT WAS: 15 AMP	12/14/06	GDK	RWT
B	1194		ADDED CONTACT DETAILS AND REVISED NOTE 5	11/17/06	KIM	RWT
A	0651		RELEASED	5/24/05	LB	RWT

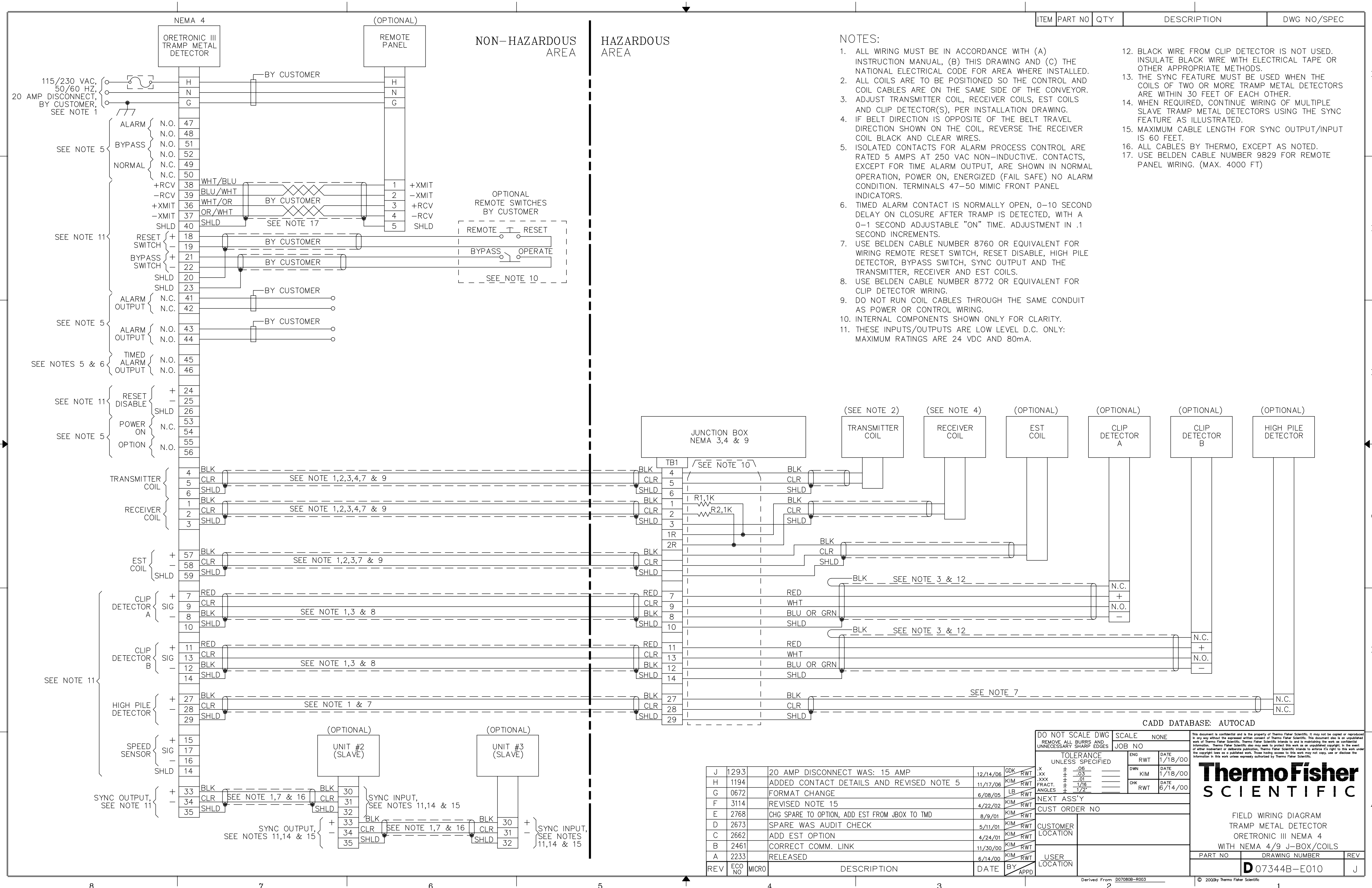

ITEM	PART NO	QTY	DESCRIPTION	DWG NO/SPEC
------	---------	-----	-------------	-------------

- NOTES:
- ALL WIRING MUST BE IN ACCORDANCE WITH (A) INSTRUCTION MANUAL, (B) THIS DRAWING AND (C) THE NATIONAL ELECTRICAL CODE FOR AREA WHERE INSTALLED.
 - ALL COILS ARE TO BE POSITIONED SO THE CONTROL AND COIL CABLES ARE ON THE SAME SIDE OF THE CONVEYOR.
 - ADJUST TRANSMITTER COIL, RECEIVER COILS, EST COILS AND CLIP DETECTOR(S), PER INSTALLATION DRAWING.
 - IF BELT DIRECTION IS OPPOSITE OF THE BELT TRAVEL DIRECTION SHOWN ON THE COIL, REVERSE THE RECEIVER COIL BLACK AND CLEAR WIRES.
 - ISOLATED CONTACTS FOR ALARM PROCESS CONTROL ARE RATED 5 AMPS AT 250 VAC NON-INDUCTIVE. CONTACTS, EXCEPT FOR TIME ALARM OUTPUT, ARE SHOWN IN NORMAL OPERATION, POWER ON, ENERGIZED (FAIL SAFE) NO ALARM CONDITION. TERMINALS 47-50 MIMIC FRONT PANEL INDICATORS.
 - TIMED ALARM CONTACT IS NORMALLY OPEN, 0-10 SECOND DELAY ON CLOSURE AFTER TRAMP IS DETECTED, WITH A 0-1 SECOND ADJUSTABLE "ON" TIME. ADJUSTMENT IN .1 SECOND INCREMENTS.
 - USE BELDEN CABLE NUMBER 8760 OR EQUIVALENT FOR WIRING REMOTE RESET SWITCH, RESET DISABLE, HIGH PILE DETECTOR, BYPASS SWITCH, SYNC OUTPUT AND THE TRANSMITTER, RECEIVER AND EST COILS.
 - USE BELDEN CABLE NUMBER 8772 OR EQUIVALENT FOR CLIP DETECTOR WIRING.
 - DO NOT RUN COIL CABLES THROUGH THE SAME CONDUIT AS POWER OR CONTROL WIRING.
 - INTERNAL COMPONENTS SHOWN ONLY FOR CLARITY.
 - THESE INPUTS/OUTPUTS ARE LOW LEVEL D.C. ONLY: MAXIMUM RATINGS ARE 24 VDC AND 80mA.
 - BLACK WIRE FROM CLIP DETECTOR IS NOT USED. INSULATE BLACK WIRE WITH ELECTRICAL TAPE OR OTHER APPROPRIATE METHODS.
 - THE SYNC FEATURE MUST BE USED WHEN THE COILS OF TWO OR MORE TRAMP METAL DETECTORS ARE WITHIN 30 FEET OF EACH OTHER.
 - WHEN REQUIRED, CONTINUE WIRING OF MULTIPLE SLAVE TRAMP METAL DETECTORS USING THE SYNC FEATURE AS ILLUSTRATED.
 - MAXIMUM CABLE LENGTH FOR SYNC OUTPUT/INPUT IS 60 FEET.
 - ALL CABLES BY THERMO, EXCEPT AS NOTED.
 - USE BELDEN CABLE NUMBER 9829 FOR REMOTE PANEL WIRING. (MAX. 4000 FT)

REV	ECO NO	MICRO	DESCRIPTION	DATE	BY	APPD
J	1293		20 AMP DISCONNECT WAS: 15 AMP	12/14/06	GDK	RWT
H	1194		ADDED CONTACT DETAILS AND REVISED NOTE 5	11/17/06	KIM	RWT
G	0672		FORMAT CHANGE	6/08/05	LB	RWT
F	3114		REVISED NOTE 15	4/22/02	KIM	RWT
E	2768		CHG SPARE TO OPTION, ADD EST FROM JBOX TO TMD	8/9/01	KIM	RWT
D	2673		SPARE WAS AUDIT CHECK	5/11/01	KIM	RWT
C	2662		ADD EST OPTION	4/24/01	KIM	RWT
B	2461		CORRECT COMM. LINK	11/30/00	KIM	RWT
A	2233		RELEASED	6/14/00	KIM	RWT

SCALE	TOLERANCE UNLESS SPECIFIED	ENG	DATE
NONE <td>± .06</td> <td>RWT</td> <td>1/18/00</td>	± .06	RWT	1/18/00
	± .03	OWN	1/18/00
	FRACT. ± .01	KIM	6/14/00
	ANGLES ± 1/16	CHK	
		RWT	

DO NOT SCALE DWG	SCALE	NONE
REMOVE ALL BURRS AND UNNECESSARY SHARP EDGES	JOB NO	
	ENG	RWT
	DATE	1/18/00
	OWN	KIM
	DATE	1/18/00
	CHK	RWT
	DATE	6/14/00

THIS DOCUMENT IS CONFIDENTIAL AND IS THE PROPERTY OF THERMO FISHER SCIENTIFIC. IT MAY NOT BE COPIED OR REPRODUCED IN ANY WAY WITHOUT THE EXPRESSED WRITTEN CONSENT OF THERMO FISHER SCIENTIFIC. THIS DOCUMENT IS AN UNPUBLISHED WORK OF THERMO FISHER SCIENTIFIC. THERMO FISHER SCIENTIFIC INTENDS TO AND IS MAINTAINING THE WORK AS CONFIDENTIAL INFORMATION. THERMO FISHER SCIENTIFIC DOES NOT SEEK TO PROTECT THIS WORK AS UNPUBLISHED COPYRIGHT. IN THE EVENT OF OTHER UNPUBLISHED OR PUBLISHED INFORMATION, THERMO FISHER SCIENTIFIC INTENDS TO ENFORCE ITS RIGHT TO THIS WORK UNDER THE COPYRIGHT LAWS AS A PUBLISHED WORK. THOSE HAVING ACCESS TO THIS WORK MAY NOT COPY, USE OR DISCLOSE THE INFORMATION IN THIS WORK UNLESS EXPRESSLY AUTHORIZED BY THERMO FISHER SCIENTIFIC.
ThermoFisher SCIENTIFIC
FIELD WIRING DIAGRAM TRAMP METAL DETECTOR ORETRONIC III NEMA 4 WITH NEMA 4/9 J-BOX/COILS
PART NO: D07344B-E010
DRAWING NUMBER: J

ITEM	PART NO	QTY	DESCRIPTION	DWG NO/SPEC
------	---------	-----	-------------	-------------

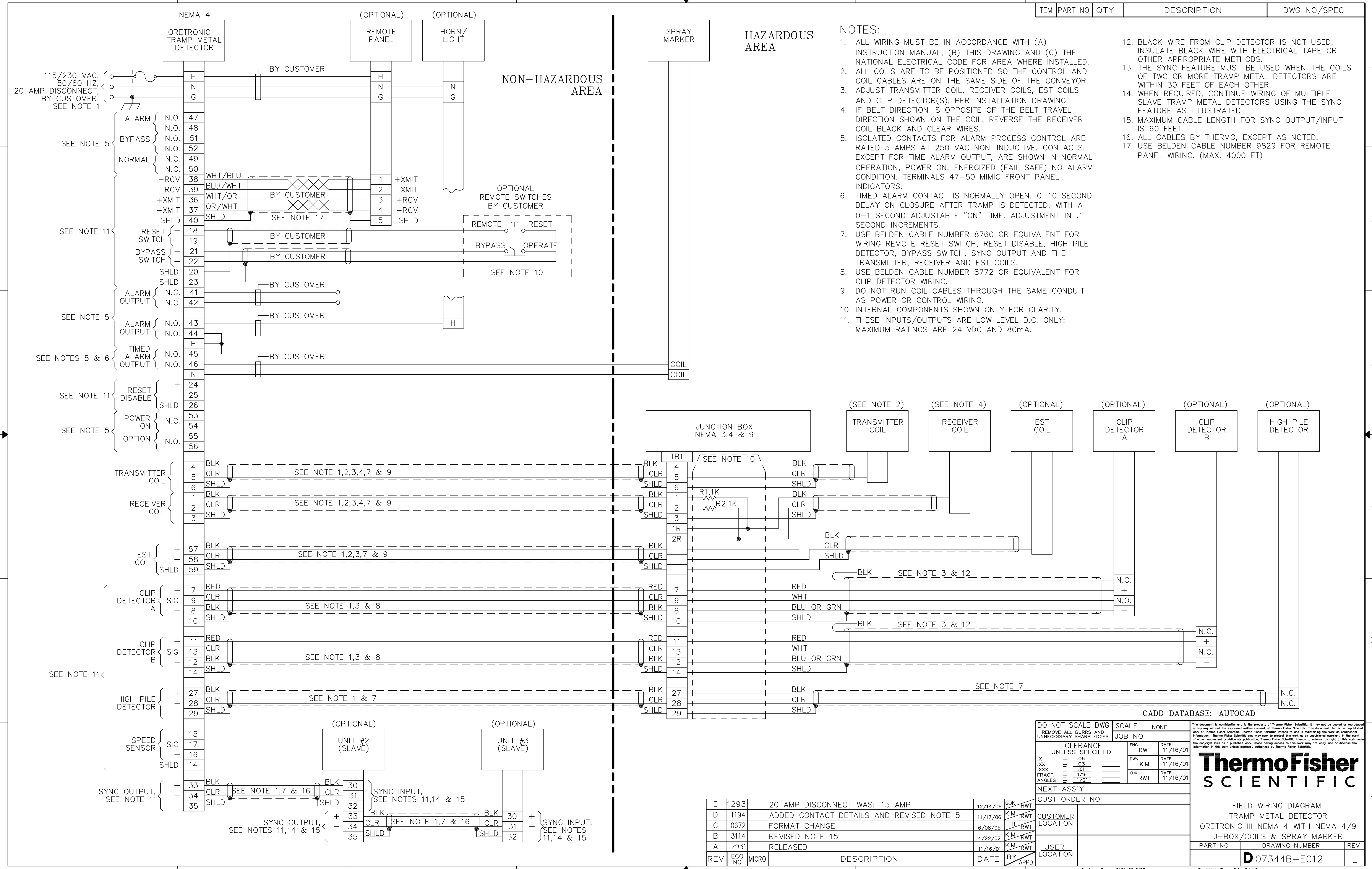

HAZARDOUS AREA

NON-HAZARDOUS AREA

NOTES:

- ALL WIRING MUST BE IN ACCORDANCE WITH (A) INSTRUCTION MANUAL, (B) THIS DRAWING AND (C) THE NATIONAL ELECTRICAL CODE FOR AREA WHERE INSTALLED.
- ALL COILS ARE TO BE POSITIONED SO THE CONTROL AND COIL CABLES ARE ON THE SAME SIDE OF THE CONVEYOR.
- ADJUST TRANSMITTER COIL, RECEIVER COILS, EST COILS AND CLIP DETECTOR(S), PER INSTALLATION DRAWING.
- IF BELT DIRECTION IS OPPOSITE OF THE BELT TRAVEL DIRECTION SHOWN ON THE COIL, REVERSE THE RECEIVER COIL BLACK AND CLEAR WIRES.
- ISOLATED CONTACTS FOR ALARM PROCESS CONTROL ARE RATED 5 AMPS AT 250 VAC NON-INDUCTIVE. CONTACTS, EXCEPT FOR TIME ALARM OUTPUT, ARE SHOWN IN NORMAL OPERATION, POWER ON, ENERGIZED (FAIL SAFE) NO ALARM CONDITION. TERMINALS 47-50 MIMIC FRONT PANEL INDICATORS.
- TIMED ALARM CONTACT IS NORMALLY OPEN, 0-10 SECOND DELAY ON CLOSURE AFTER TRAMP IS DETECTED, WITH A 0-1 SECOND ADJUSTABLE "ON" TIME. ADJUSTMENT IN .1 SECOND INCREMENTS.
- USE BELDEN CABLE NUMBER 8760 OR EQUIVALENT FOR WIRING REMOTE RESET SWITCH, RESET DISABLE, HIGH PILE DETECTOR, BYPASS SWITCH, SYNC OUTPUT AND THE TRANSMITTER, RECEIVER AND EST COILS.
- USE BELDEN CABLE NUMBER 8772 OR EQUIVALENT FOR CLIP DETECTOR WIRING.
- DO NOT RUN COIL CABLES THROUGH THE SAME CONDUIT AS POWER OR CONTROL WIRING.
- INTERNAL COMPONENTS SHOWN ONLY FOR CLARITY.
- THESE INPUTS/OUTPUTS ARE LOW LEVEL D.C. ONLY: MAXIMUM RATINGS ARE 24 VDC AND 80mA.
- BLACK WIRE FROM CLIP DETECTOR IS NOT USED. INSULATE BLACK WIRE WITH ELECTRICAL TAPE OR OTHER APPROPRIATE METHODS.
- THE SYNC FEATURE MUST BE USED WHEN THE COILS OF TWO OR MORE TRAMP METAL DETECTORS ARE WITHIN 30 FEET OF EACH OTHER.
- WHEN REQUIRED, CONTINUE WIRING OF MULTIPLE SLAVE TRAMP METAL DETECTORS USING THE SYNC FEATURE AS ILLUSTRATED.
- MAXIMUM CABLE LENGTH FOR SYNC OUTPUT/INPUT IS 60 FEET.
- ALL CABLES BY THERMO, EXCEPT AS NOTED.
- USE BELDEN CABLE NUMBER 9829 FOR REMOTE PANEL WIRING. (MAX. 4000 FT)

DO NOT SCALE DWG		SCALE NONE	
REMOVE ALL BURRS AND UNNECESSARY SHARP EDGES		JOB NO	
TOLERANCE UNLESS SPECIFIED		ENG RWT	DATE 11/16/01
.x	± .06	OWN	DATE 11/16/01
.xx	± .03	KIM	DATE 11/16/01
.xxx	± .01	CHK	DATE 11/16/01
FRACT.	± 1/16		
ANGLES	± 1/2°		

Thermo Fisher SCIENTIFIC

FIELD WIRING DIAGRAM
TRAMP METAL DETECTOR
ORETRONIC III NEMA 4 WITH NEMA 4/9
J-BOX/COILS & SPRAY MARKER

REV	ECO NO	MICRO	DESCRIPTION	DATE	BY	APPD
E	1293		20 AMP DISCONNECT WAS: 15 AMP	12/14/06	GDK	RWT
D	1194		ADDED CONTACT DETAILS AND REVISED NOTE 5	11/17/06	KIM	RWT
C	0672		FORMAT CHANGE	8/08/05	LB	RWT
B	3114		REVISED NOTE 15	4/22/02	KIM	RWT
A	2931		RELEASED	11/16/01	KIM	RWT

PART NO	D07344B-E012	DRAWING NUMBER	REV	E
---------	--------------	----------------	-----	---

ITEM	PART NO	QTY	DESCRIPTION	DWG NO/SPEC
1	067035	1	BRKT,SIDE,ORE III,UND BELT,SGL	D07328C-C108
2	SEE TAB	2	COIL,SUPPORT,CROSS BRACKET	SEE TAB
3	003129	8	WASHER,FLAT, 3/8 ZN	
4	003125	8	WASHER,LOCK,SPRING, 3/8 ZN	
5	013851	8	SCR,LAG,HEX, 3/8X 6.000 ZN	
6	066101	SEE TAB	SCR,CAP,HEXFLG,1/2-13X 5.0 FGL	
7	066097	2	NUT,HEX, 1/2-13 GRY FBRGL	
8	066350	4	SCR,CAP,HEXFLG,1/2-13X 2.0 FGL	
9	067663	1	BRKT,SIDE,ORE III,UND BELT,SGL	D07328C-C109
10	068383	SEE TAB	SCR,CAP,HEXFLG,1/2-13X 6.0 FGL	

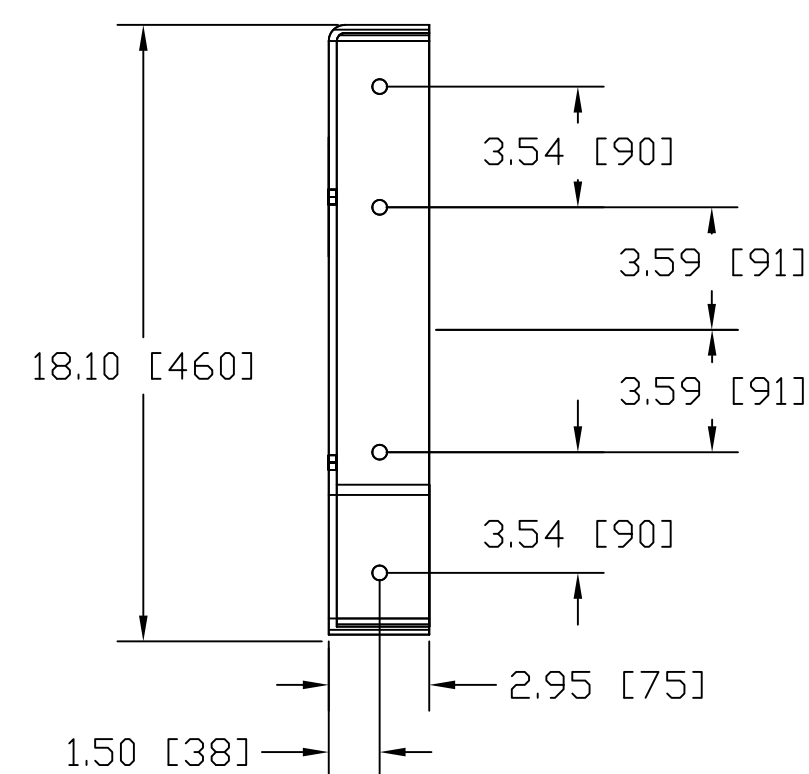
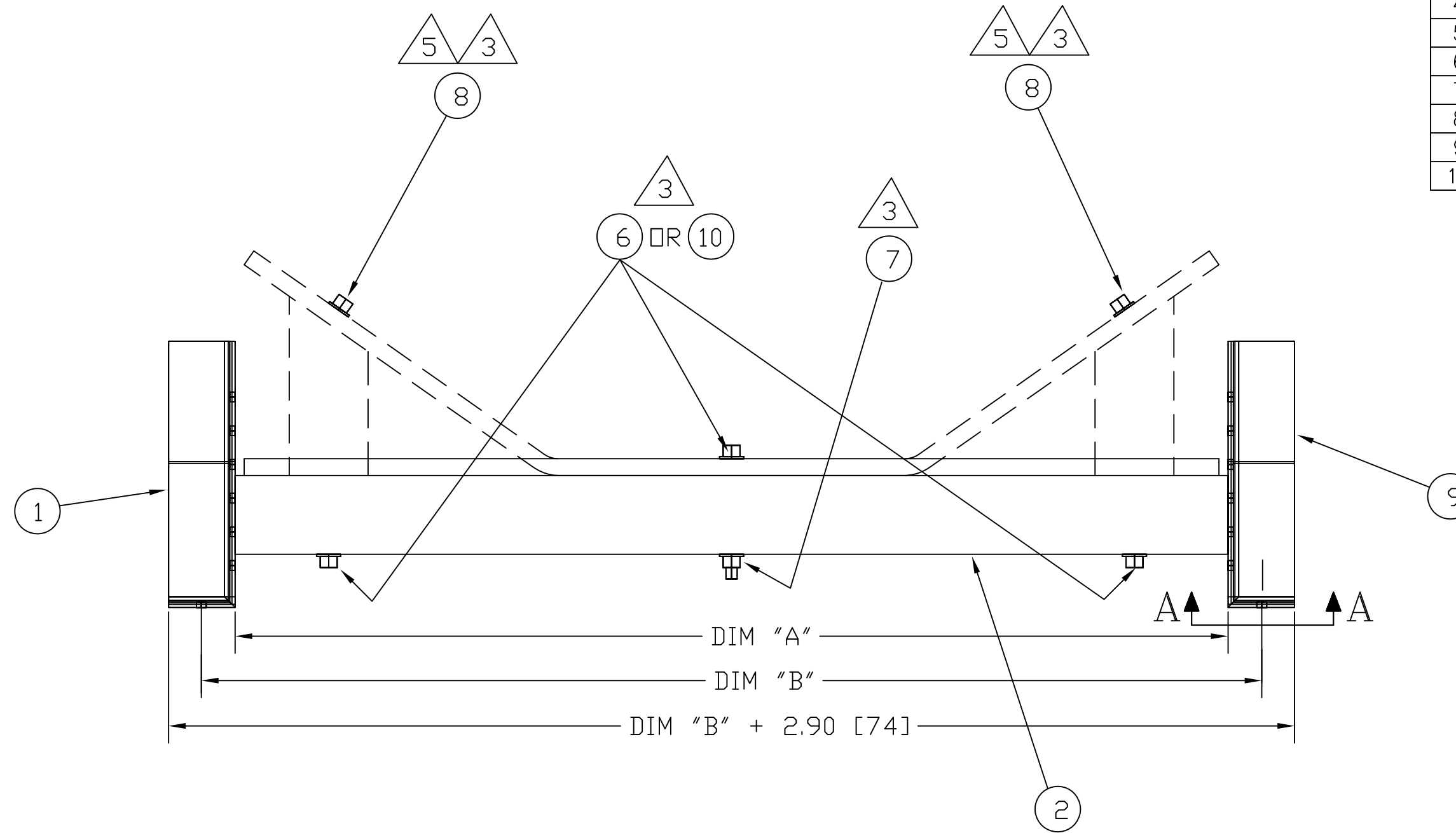
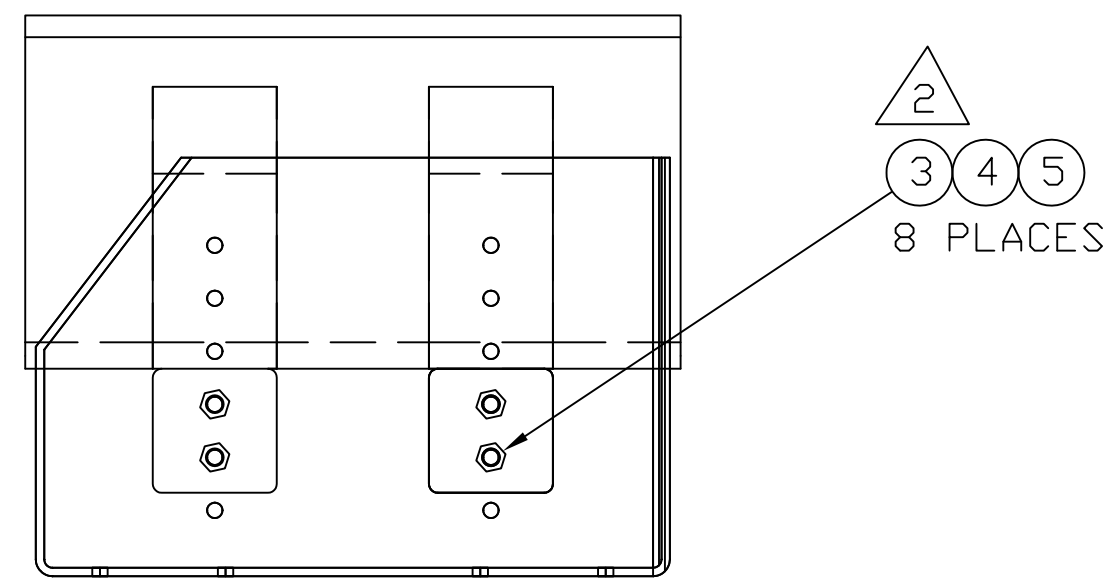

VIEW A-A

-24	067034		96		111 [2819]	108 [2743]	067058	C07328C-C115-24	0	6
-23	067033	96			105 [2667]	102 [2591]	067057	C07328C-C115-23	0	6
-22	091457			2200 mm	100.94 [2564]	103.94 [2640]	091462	C07328C-C115-22	0	6
-21	067032		84		99 [2515]	96 [2438]	067056	C07328C-C115-21	0	6
-20	067031	84			93 [2362]	90 [2286]	067055	C07328C-C115-20	0	6
-19	067030			1800 mm	87.38 [2219]	84.38 [2143]	067054	C07328C-C115-19	0	6
-18	037029		72		87 [2210]	84 [2134]	067053	C07328C-C115-18	0	6
-17	067028	72			81 [2057]	78 [1981]	067052	C07328C-C115-17	0	6
-16	067027			1600 mm	76 [1930]	73 [1854]	067051	C07328C-C115-16	0	6
-15	067026		60		75 [1905]	72 [1829]	067050	C07328C-C115-15	0	6
-14	067025	60	54		69 [1753]	66 [1676]	067049	C07328C-C115-14	6	0
-13	067024			1400 mm	68.12 [1730]	65.12 [1654]	067048	C07328C-C115-13	6	0
-12	067023	54	48		63 [1600]	60 [1524]	067047	C07328C-C115-12	6	0
-11	067022			1200 mm	58.62 [1489]	55.62 [1413]	067046	C07328C-C115-11	6	0
-10	067021	48	42		57 [1448]	54 [1372]	067045	C07328C-C115-10	6	0
-09	067020			1050 mm	52.75 [1340]	49.75 [1264]	067044	C07328C-C115-09	6	0
-08	067019	42	36		51 [1295]	48 [1219]	067043	C07328C-C115-08	6	0
-07	067018			900 mm	46.88 [1191]	43.88 [1114]	067042	C07328C-C115-07	6	0
-06	067017	36	30		45 [1143]	42 [1067]	067041	C07328C-C115-06	6	0
-05	067016			750 mm	41 [1041]	38 [965]	067040	C07328C-C115-05	6	0
-04	067015	30	24		39 [991]	36 [914]	067039	C07328C-C115-04	6	0
-03	067014	24		600 mm	33 [838]	30 [762]	067038	C07328C-C115-03	6	0
-02	067013	20		500 mm	29 [737]	26 [660]	067037	C07328C-C115-02	6	0
-01	067012	18		450 mm	27 [686]	24 [610]	067036	C07328C-C115-01	6	0
VERSION	PART NO.	U.S. BELT + 9 INCHES STD. BELT WIDTH	U.S. BELT + 15 INCHES WIDE BASE B.W.	METRIC BELT	"B" DIM	"A" DIM	PART NO.	DRAWING NUMBER	QTY	QTY
							ITEM 2		ITEM 6	ITEM 10

NOTE:

1. READ ALL NOTES BEFORE STARTING ASSEMBLY.
2. TORQUE NOT TO EXCEED 200 IN. LBS.
3. TORQUE NOT TO EXCEED 80 IN. LBS.
4. DIMENSIONS ARE IN INCHES AND [MILLIMETERS].
5. FOR CONTOURED COILS THE WEDGES AND HARDWARE ARE SUPPLIED WITH COIL.

CADD DATABASE: AUTOCAD METRIC A1

DO NOT SCALE DWG	SCALE NONE	<small>This document is confidential and is the property of Thermo Fisher Scientific. It may not be copied or reproduced in any way without the expressed written consent of Thermo Fisher Scientific. This document also is an unpublished work of Thermo Fisher Scientific. Thermo Fisher Scientific intends to and is maintaining the work as confidential information. Thermo Fisher Scientific also may seek to protect this work as an unpublished copyright. In the event of other treatment or subsequent publication, Thermo Fisher Scientific intends to enforce its right in the work under the copyright law as a published work. Those using access to this work may not copy, use or disclose the information in this work unless expressly authorized by Thermo Fisher Scientific.</small>				
REMOVE ALL BURRS AND UNNECESSARY SHARP EDGES	JOB NO					
TOLERANCE UNLESS SPECIFIED	ENG LOC DATE 8-29-00	<p>UNDER BELT SINGLE COIL ASSEMBLY, STAND TRAMP METAL DETECTOR</p>				
.X ± 1.5 mm .06 in	DWN DATE 8-29-00					
.XX ± 0.8 mm .03 in	LOC DATE 8-29-00					
.XXX ± 0.3 mm .01 in	CHK DATE 10-25-00					
FRACT. ± 1/16 1/16	JLB					
ANGLES ± .50° .12°						
NEXT ASS'Y						
CUST ORDER NO						
CUSTOMER LOCATION						
USER LOCATION						
REV	ECO NO	MICRO	DESCRIPTION	DATE	BY	APPD
E	2180		ADDED BALLONS	4-21-10	RAE	RAE
D	1281		ADDED VERSION -24	12/26/06	QDK	RWT
C	3487		ADD NOTE 5	8/1/03	KIM	RWT
B	3439		ADD ITEM 10, ADD ITEM 6 TO TAB	5/19/03	KIM	RWT
A	2233		GENERAL CLEANUP	11/14/00	LOC	JLB
PART NO	DRAWING NUMBER		REV			
	D07328C-A110-XX		E			

ITEM	PART NO	QTY	DESCRIPTION	DWG NO/SPEC
------	---------	-----	-------------	-------------

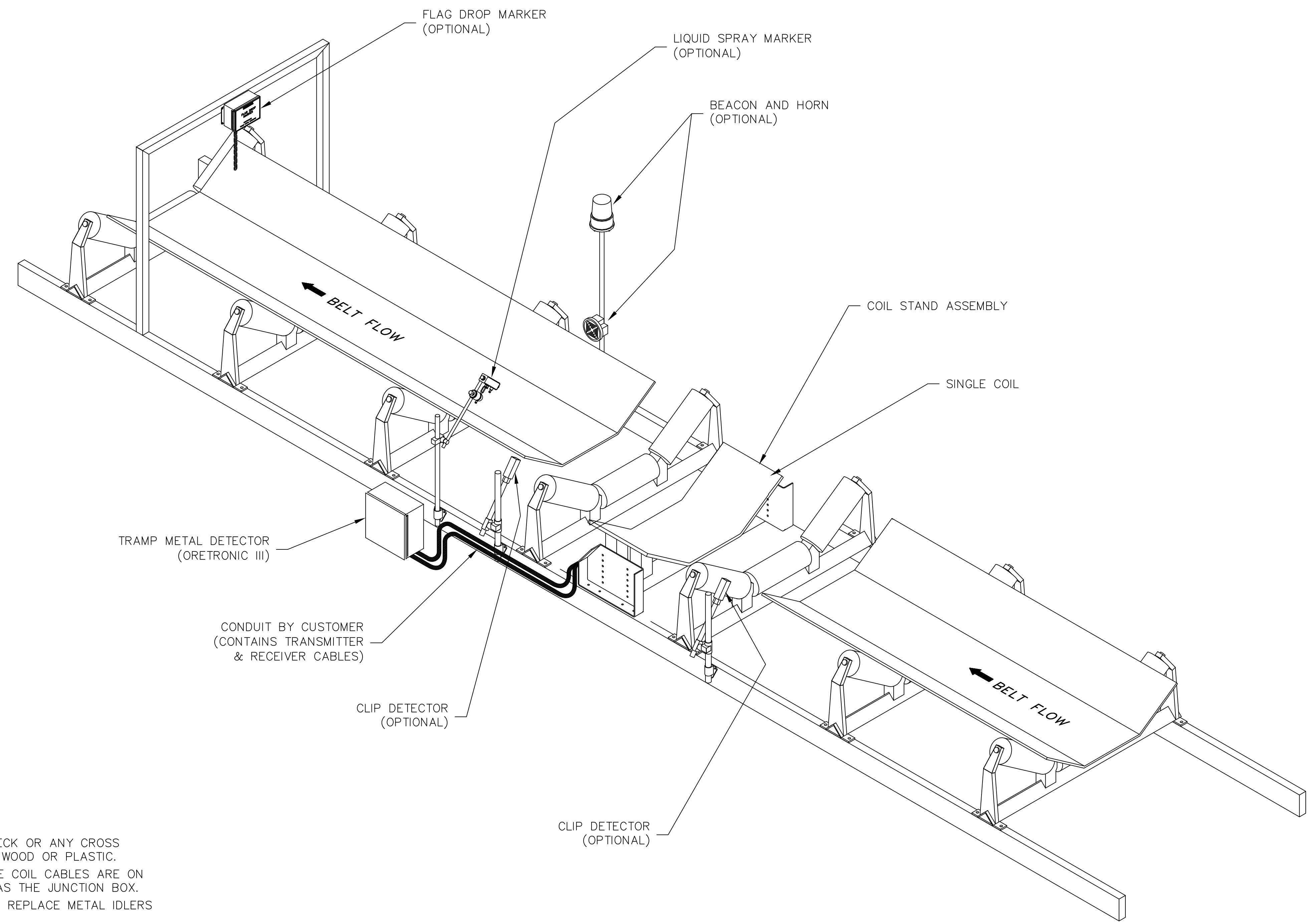

NOTE:

1. REMOVE OR REPLACE METAL DUST DECK OR ANY CROSS MEMBERS BETWEEN STRINGERS WITH WOOD OR PLASTIC.
2. COIL TO BE POSITIONED SO THAT THE COIL CABLES ARE ON THE SAME SIDE OF THE CONVEYOR AS THE JUNCTION BOX.
4. IF IDLER SPACING IS LESS THAN 48", REPLACE METAL IDLERS WITH RUBBER IMPACT TYPE.
5. CLIP DETECTOR(S) SHOULD BE LOCATED PER DETECTOR DETAIL.
6. RECEIVER COIL CABLES TO ORETRONIC III MAY BE SHORTENED BUT NOT SPLICED. (CABLES BY THERMO)
7. TRANSMITTER COIL CABLE TO ORETRONIC III MAY BE SHORTENED BUT NOT SPLICED. (CABLE BY THERMO)
8. OPTIONAL CLIP DETECTOR(S) CABLES MAY BE SHORTENED BUT NOT SPLICED. (CABLES BY THERMO)
9. IF BELT DIRECTION IS OPPOSITE OF BELT DIRECTION MARKED ON THE COIL, SEE THE FIELD WIRING DRAWING.

CADD DATABASE: AUTOCAD

DO NOT SCALE DWG		SCALE	N/A
REMOVE ALL BURRS AND UNNECESSARY SHARP EDGES		JOB NO	
TOLERANCE UNLESS SPECIFIED		ENG RWT	DATE 5/24/00
.X	± .06	OWN	DATE 5/24/00
.XX	± .03	CHK	DATE 6/15/00
.XXX	± .01	RWT	
FRACT.	± 1/16		
ANGLES	± 1/2"		

This document is confidential and is the property of Thermo Fisher Scientific. It may not be copied or reproduced in any way without the expressed written consent of Thermo Fisher Scientific. This document also is an unpublished work of Thermo Fisher Scientific. Thermo Fisher Scientific intends to and is maintaining the work as confidential information. Thermo Fisher Scientific does not intend to protect this work as an unpublished copyright. In the event of other intellectual or database publications, Thermo Fisher Scientific intends to enforce its right to this work under the copyright laws as a published work. Those having access to this work may not copy, use or disclose the information in this work unless expressly authorized by Thermo Fisher Scientific.

Thermo Fisher SCIENTIFIC

UNDER BELT SINGLE COIL
FINAL ASSEMBLY
ORETRONIC III
TRAMP METAL DETECTOR

C	2180	CORRECT LOGO	4-20-10	RAE	RAE
B	0854	FORMAT CHANGE	6/10/05	LE	RWT
A	2233	RELEASED	6/15/00	KIM	RWT
REV	ECO NO	MICRO	DESCRIPTION	DATE	BY APFD

NEXT ASS'Y	
CUST ORDER NO	
CUSTOMER LOCATION	
USER LOCATION	

PART NO	D07328C-A101	REV	C
---------	--------------	-----	---

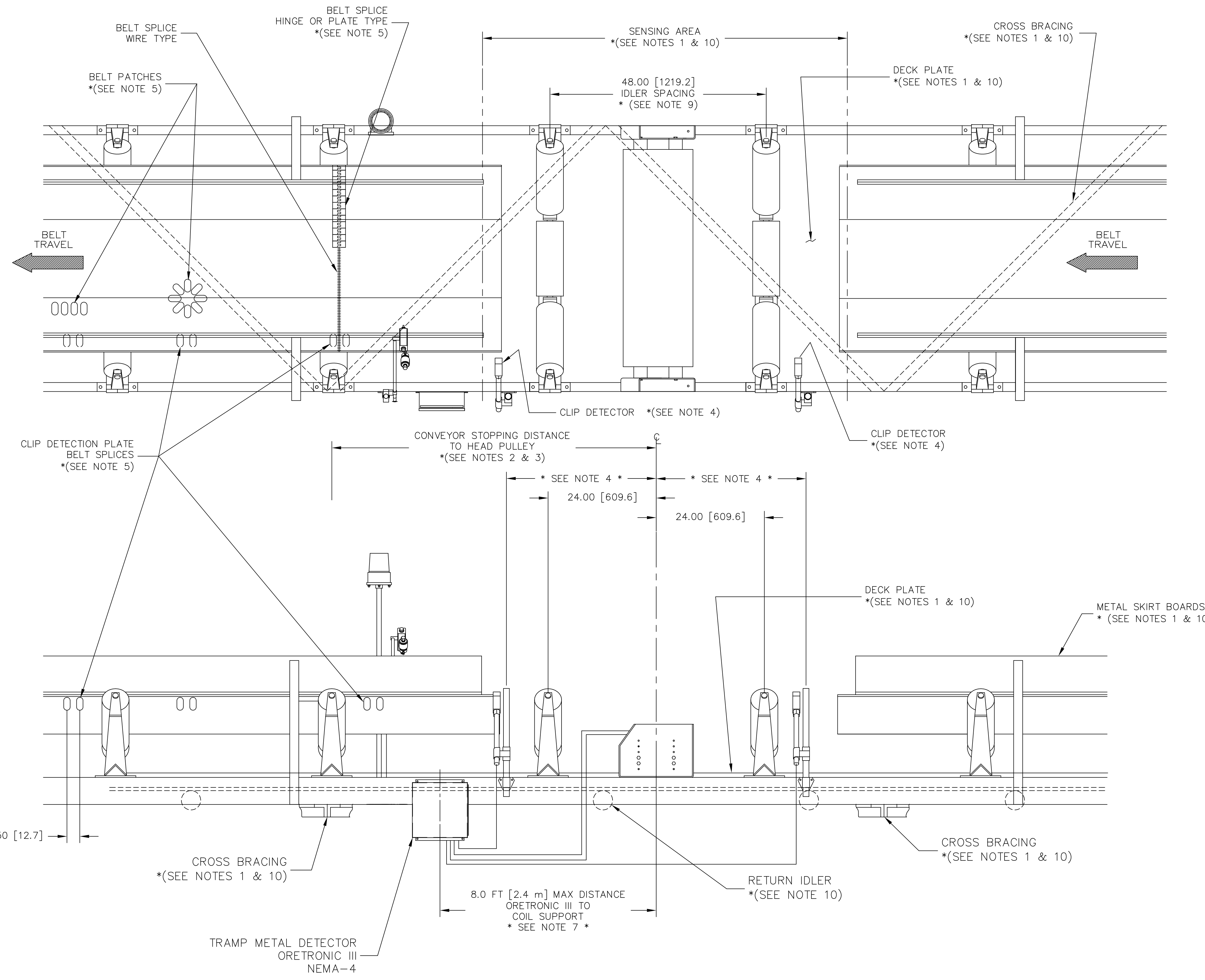

NOTE:

- SEE MANUAL FOR REQUIRED METAL REMOVAL IN SENSING AREA.
- COIL SUPPORT STRUCTURE TO BE LOCATED SO THAT CONVEYOR WILL STOP BEFORE ANY TRAMP IS DISCHARGED.
- SPRAY MARKER, FLAG DROP, OR DIVERTER CHUTE TO BE LOCATED WITHIN 10 SECONDS OF COIL SUPPORT STRUCTURE BUT NOT CLOSER THAN 3 FT.
- LOCATE THE CLIP DETECTOR(S) 3 TO 4 INCHES FROM IDLER CLOSEST TO COIL SUPPORT STRUCTURE.
- IF THE BELT SPLICE IS WIRE OR IF A HOLE OR TEAR IN THE BELT IS FIXED WITH METAL SPLICES, INSTALL TWO PLATE BELT SPLICES ON THE OUTER EDGE OF THE BELT FOR CLIP DETECTION.
- POSITION CLIP DETECTOR(S) FOR 1/4" CLEARANCE FROM BELT WHEN LOADED.
- 15 FT. CABLE FROM TRANSMITTER COIL, 10 FT. CABLE FROM RECEIVER COILS AND 20 FT. CABLE FROM CLIP DETECTOR (BY THERMO), THEY MAY BE SHORTENED BUT NOT SPLICED.
- NO MAGNETS WITHIN 18 FT. OF COILS.
- IDLER SPACING IN COIL AREA SHOULD BE 48" OR LARGER. IF FOR MECHANICAL REASONS THIS SPACING IS NOT POSSIBLE THE DISTANCE MAY BE REDUCED BY USING RUBBER IMPACT IDLERS.
- METAL PIPES, CONDUITS, DUCT WORK, RETURN ROLLERS, DECK PLATES, AND CROSS BRACING SHOULD BE NO CLOSER THAN 4 FT. FROM COILS. INLET AND OUTLET CHUTES, AND SKIRTBOARDS SHOULD BE NO CLOSER THAN 8 FT. FROM COILS.

CADD DATABASE: AUTOCAD

DO NOT SCALE DWG	SCALE	N/A
REMOVE ALL BURRS AND UNNECESSARY SHARP EDGES	JOB NO	
TOLERANCE UNLESS SPECIFIED	ENG	DATE
.x ± .06	LOC	8-22-00
.xx ± .03	OWN	DATE
.xxx ± .01	LOC	8-22-00
FRACT ± 1/16	CHK	DATE
ANGLES ± 1/2"	LOC	8-22-00

This document is confidential and is the property of Thermo Fisher Scientific. It may not be copied or reproduced in any way without the expressed written consent of Thermo Fisher Scientific. This document also is an unpublished work of Thermo Fisher Scientific. Thermo Fisher Scientific intends to and is maintaining the work as confidential information. Thermo Fisher Scientific also may seek to protect the work as an unpublished copyright. In the event of other industrial or scientific publications, Thermo Fisher Scientific intends to enforce its right to this work under the copyright laws as a published work. Those having access to this work may not copy, use or disclose the information in this work unless expressly authorized by Thermo Fisher Scientific.

Thermo Fisher SCIENTIFIC

UNDER BELT SINGLE COIL INSTALLATION PLACEMENT
ORETRONIC III, TMD
SHEET 1 OF 2

C	2180	CORRECT LOGO	4-21-10	RAE	RAE
B	0854	FORMAT CHANGE	6/11/05	LE	RTW
A	2233	RELEASED	8-22-00	LOC	
REV	ECO NO	MICRO	DATE	BY	APPD

NEXT ASS'Y	
CUST ORDER NO	
CUSTOMER LOCATION	
USER LOCATION	

PART NO	D07328C-A102
DRAWING NUMBER	
REV	C

ITEM	PART NO	QTY	DESCRIPTION	DWG NO/SPEC
------	---------	-----	-------------	-------------

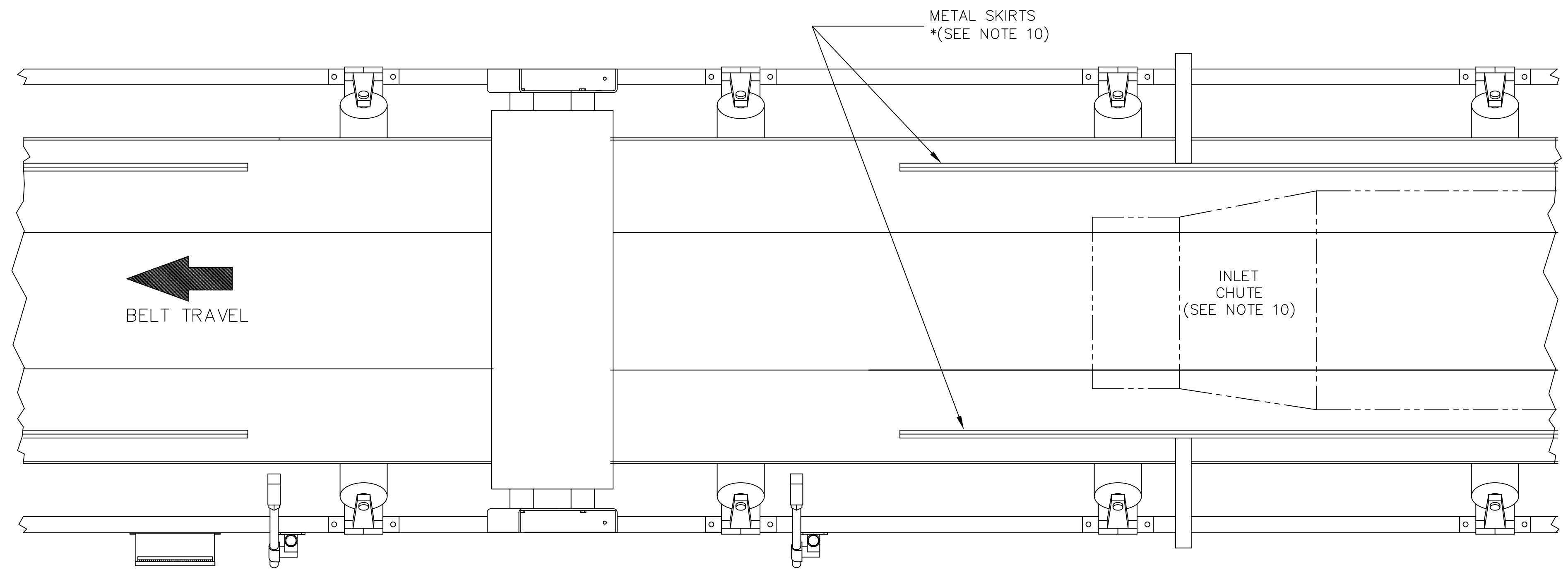

METAL PIPE, CONDUIT (SEE NOTE 10)

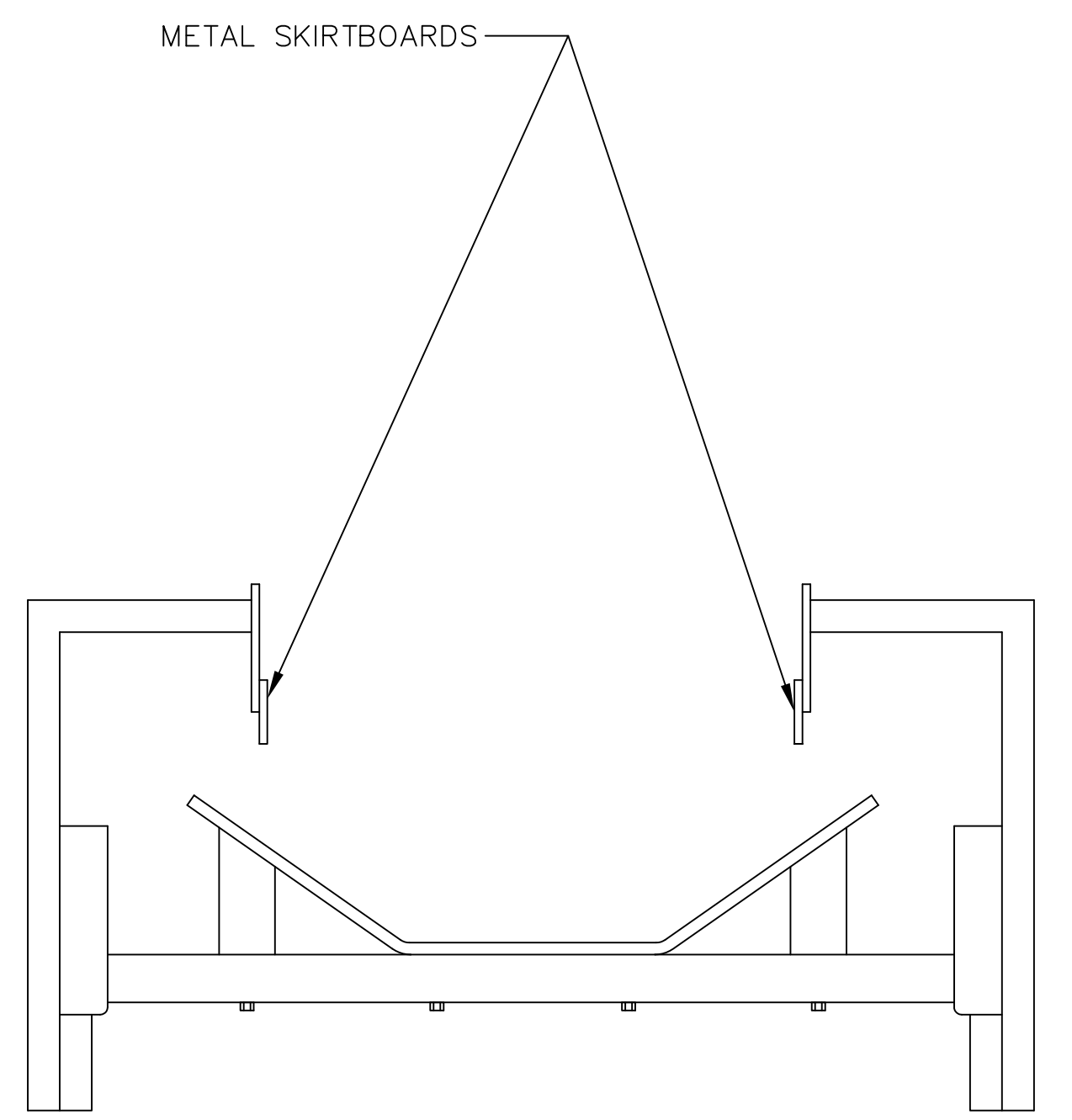
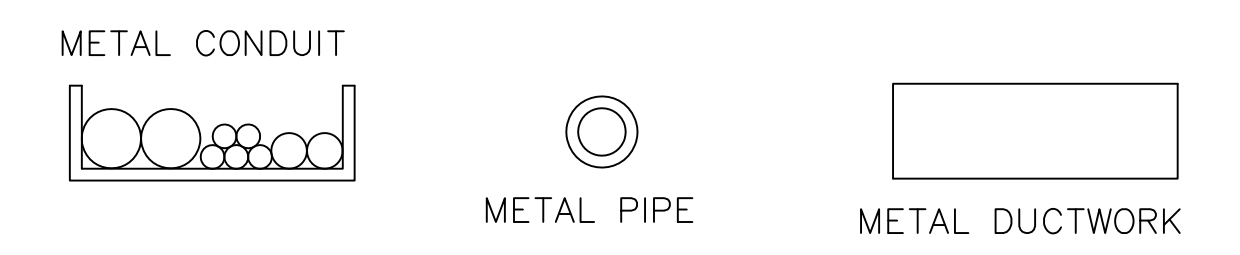

SEE NOTES ON SHEET 1 OF 2

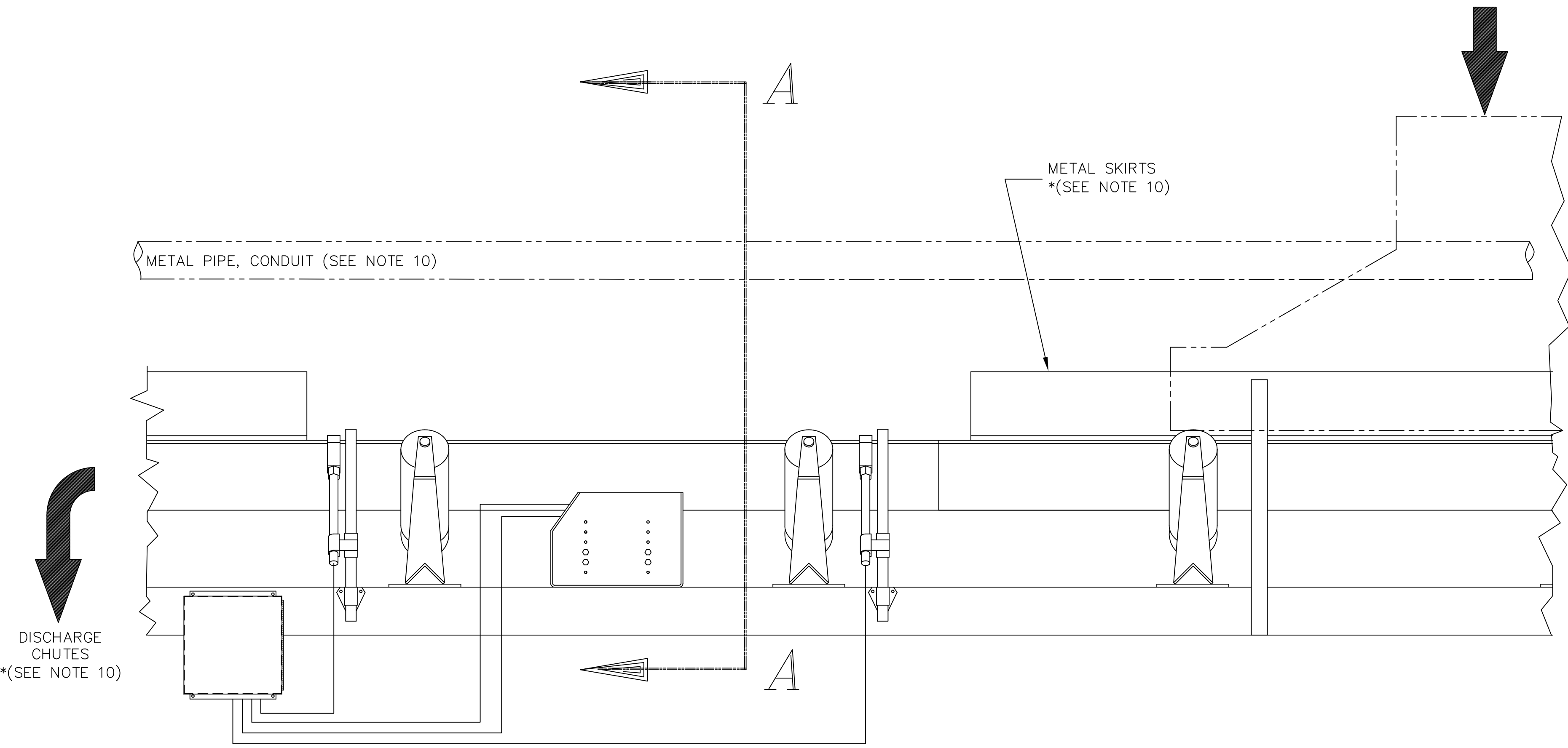

CADD DATABASE: AUTOCAD

DO NOT SCALE DWG		SCALE N/A	
REMOVE ALL BURRS AND UNNECESSARY SHARP EDGES		JOB NO	
TOLERANCE UNLESS SPECIFIED	ENG	LOC	DATE
.x ± .06	LOC	8-22-00	
.xx ± .03	OWN	8-22-00	
.xxx ± .01	LOC	8-22-00	
FRACT ± 1/16	CHK	8-22-00	
ANGLES ± 1/2°	LOC	8-22-00	

This document is confidential and is the property of Thermo Fisher Scientific. It may not be copied or reproduced in any way without the expressed written consent of Thermo Fisher Scientific. This document also is an unpublished work of Thermo Fisher Scientific. Thermo Fisher Scientific intends to and is maintaining the work as confidential information. Thermo Fisher Scientific does not intend to protect this work as an unpublished copyright. In the event of other industrial or scientific publications, Thermo Fisher Scientific intends to enforce its right to this work under the copyright laws as a published work. Those having access to this work may not copy, use or disclose the information in this work unless expressly authorized by Thermo Fisher Scientific.

Thermo Fisher SCIENTIFIC

UNDER BELT SINGLE COIL
INSTALLATION PLACEMENT
ORETRONIC III, TMD
SHEET 2 OF 2

NEXT ASS'Y	
CUSTOMER LOCATION	
USER LOCATION	

PART NO	DRAWING NUMBER	REV
	D07328C-A102	C

REV	ECO NO	MICRO	DESCRIPTION	DATE	BY	APPD
			SEE SHEET 1 OF 2			

ITEM	PART NO	QTY	DESCRIPTION	DWG NO/SPEC
------	---------	-----	-------------	-------------

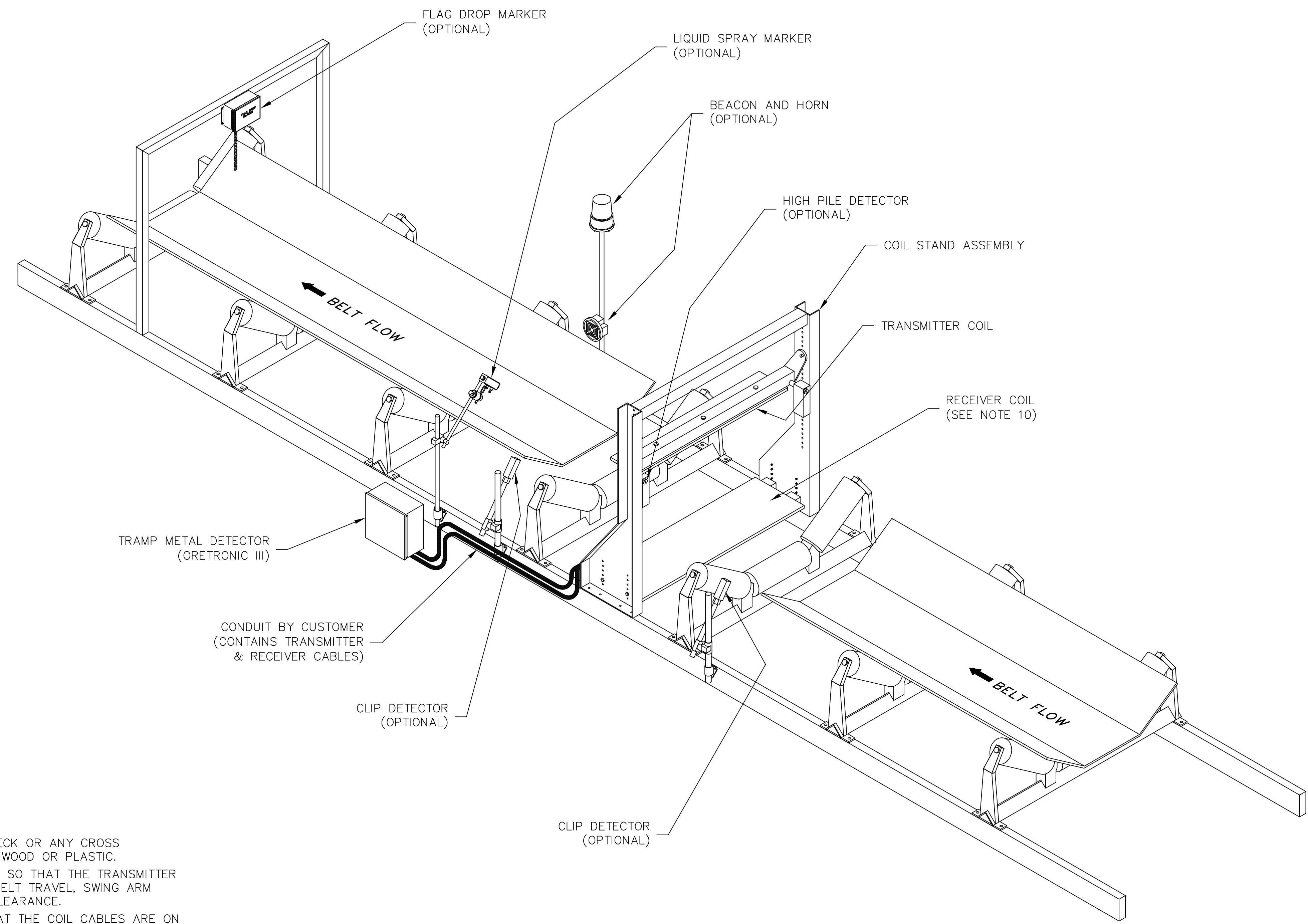

NOTE:

1. REMOVE OR REPLACE METAL DUST DECK OR ANY CROSS MEMBERS BETWEEN STRINGERS WITH WOOD OR PLASTIC.
2. SUPPORT FRAME MUST BE INSTALLED SO THAT THE TRANSMITTER COIL SWINGS IN THE DIRECTION OF BELT TRAVEL, SWING ARM ALLOWS FOR 11.5" OF ADDITIONAL CLEARANCE.
3. ALL COILS TO BE POSITIONED SO THAT THE COIL CABLES ARE ON THE SAME SIDE OF THE CONVEYOR AS THE JUNCTION BOX.
4. IF IDLER SPACING IS LESS THAN 48", REPLACE METAL IDLERS WITH RUBBER IMPACT TYPE.
5. ADJUST TRANSMITTER COIL TO GIVE CLEARANCE FOR MAXIMUM EXPECTED BURDEN.
6. CLIP DETECTOR(S) SHOULD BE LOCATED PER DETECTOR DETAIL.
7. 10 FT. RECEIVER COIL CABLES TO ORETRONIC III MAY BE SHORTENED BUT NOT SPLICED. (CABLES BY THERMO)
8. 15 FT. TRANSMITTER COIL CABLE TO ORETRONIC III MAY BE SHORTENED BUT NOT SPLICED. (CABLE BY THERMO)
9. 20 FT. RECEIVER AND OPTIONAL CLIP DETECTOR(S) CABLES MAY BE SHORTENED BUT NOT SPLICED. (CABLES BY THERMO)
10. IF BELT DIRECTION IS OPPOSITE OF BELT DIRECTION MARKED ON THE RECEIVER COIL, SEE THE FIELD WIRING DRAWING.

CADD DATABASE: AUTOCAD

DO NOT SCALE DWG		SCALE	N/A
REMOVE ALL BURRS AND UNNECESSARY SHARP EDGES		JOB NO	
TOLERANCE UNLESS SPECIFIED		ENG RWT	DATE 1/25/00
.x	± .06	OWN	DATE 1/25/00
.xx	± .03	KIM	DATE 1/25/00
.xxx	± .01	CHK	DATE 6/13/00
FRACT.	± 1/16	RWT	
ANGLES	± 1/2°		

This document is confidential and is the property of Thermo Fisher Scientific. It may not be copied or reproduced in any way without the expressed written consent of Thermo Fisher Scientific. This document also is an unpublished work of Thermo Fisher Scientific. Thermo Fisher Scientific intends to and is maintaining the work as confidential information. Thermo Fisher Scientific also may seek to protect this work as an unpublished copyright. In the event of other industrial or scientific publications, Thermo Fisher Scientific intends to enforce its right to this work under the copyright laws as a published work. Those having access to this work may not copy, use or disclose the information in this work unless expressly authorized by Thermo Fisher Scientific.

ThermoFisher
SCIENTIFIC

FINAL ASSEMBLY,
ORETRONIC III TRAMP METAL DETECTOR
STANDARD SYSTEM, NEMA 4

REV	ECO NO	MICRO	DESCRIPTION	DATE	BY	APPD
D	1964		TURN ON LAYER 3 FOR IDLERS	12/4/08	KIM	KIM
C	0854		FORMAT CHANGE	6/10/05	LB	RWT
B	2877		COMPANY NAME CHANGE ON FLAG DROP MARKER	10/2/01	KIM	RWT
A	2233		RELEASED	6/13/00	KIM	RWT

NEXT ASS'Y	
CUSTOMER LOCATION	
USER LOCATION	

PART NO	DRAWING NUMBER	REV
	D 07328C-A001	D

NOTE:

- SEE MANUAL FOR REQUIRED METAL REMOVAL IN SENSING AREA.
- COIL SUPPORT STRUCTURE TO BE LOCATED SO THAT CONVEYOR WILL STOP BEFORE ANY TRAMP IS DISCHARGED.
- SPRAY MARKER, FLAG DROP, OR DIVERTER CHUTE TO BE LOCATED WITHIN 10 SECONDS OF COIL SUPPORT STRUCTURE BUT NOT CLOSER THAN 3 FT.
- LOCATE THE CLIP DETECTOR(S) 3 TO 4 INCHES FROM IDLER CLOSEST TO COIL SUPPORT STRUCTURE.
- IF THE BELT SPLICE IS WIRE OR IF A HOLE OR TEAR IN THE BELT IS FIXED WITH METAL SPLICES, INSTALL TWO PLATE BELT SPLICES ON THE OUTER EDGE OF THE BELT FOR CLIP DETECTION.
- POSITION CLIP DETECTOR(S) FOR 1/4" CLEARANCE FROM BELT WHEN LOADED.
- 15 FT. CABLE FROM TRANSMITTER COIL, 10 FT. CABLE FROM RECEIVER COILS AND 20 FT. CABLE FROM CLIP DETECTOR (BY THERMO), THEY MAY BE SHORTENED BUT NOT SPLICED.
- NO MAGNETS WITHIN 18 FT. OF COILS.
- IDLER SPACING IN COIL AREA SHOULD BE 48" OR LARGER. IF FOR MECHANICAL REASONS THIS SPACING IS NOT POSSIBLE THE DISTANCE MAY BE REDUCED BY USING RUBBER IMPACT IDLERS.
- METAL PIPES, CONDUITS, DUCT WORK, RETURN ROLLERS, DECK PLATES, AND CROSS BRACING SHOULD BE NO CLOSER THAN 4 FT. FROM COILS. INLET AND OUTLET CHUTES, AND SKIRTBOARDS SHOULD BE NO CLOSER THAN 8 FT. FROM COILS.

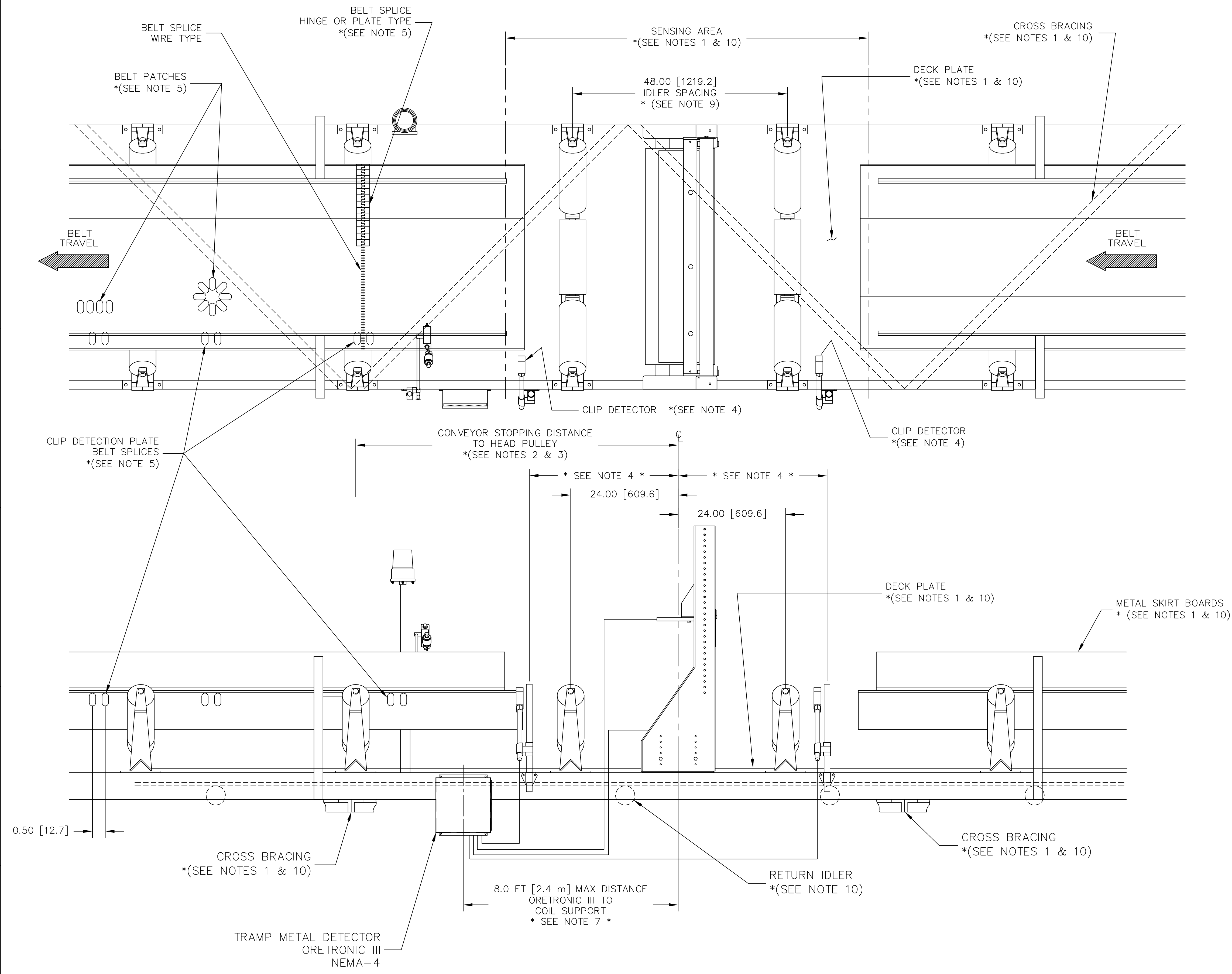

REV	ECO NO	MICRO	DESCRIPTION	DATE	BY	APPD
C	2180		CORRECT LOGO	4-21-10	RAE	RAE
B	0854		FORMAT CHANGE	6/10/05	LEB	RWT
A	2233		RELEASED	6/13/00	KIM	RWT

CADD DATABASE: AUTOCAD

DO NOT SCALE DWG	SCALE	N/A
REMOVE ALL BURRS AND UNNECESSARY SHARP EDGES	JOB NO	
TOLERANCE UNLESS SPECIFIED	ENG	RWT
.x ± .06	DATE	1/25/00
.xx ± .03	OWN	KIM
.xxx ± .01	DATE	1/25/00
FRACT ± 1/16	CHK	RWT
ANGLES ± 1/2°	DATE	6/13/00

ThermoFisher SCIENTIFIC

INSTALLATION PLACEMENT
ORETRONIC III TRAMP METAL DETECTOR
STANDARD SYSTEM, NEMA 4
SHEET 1 OF 2

CUSTOMER LOCATION	PART NO	DRAWING NUMBER	REV
	D07328C-A002		C

Derived From: 007080A-1009
© 2000 by Thermo Fisher Scientific

ITEM	PART NO	QTY	DESCRIPTION	DWG NO/SPEC
------	---------	-----	-------------	-------------

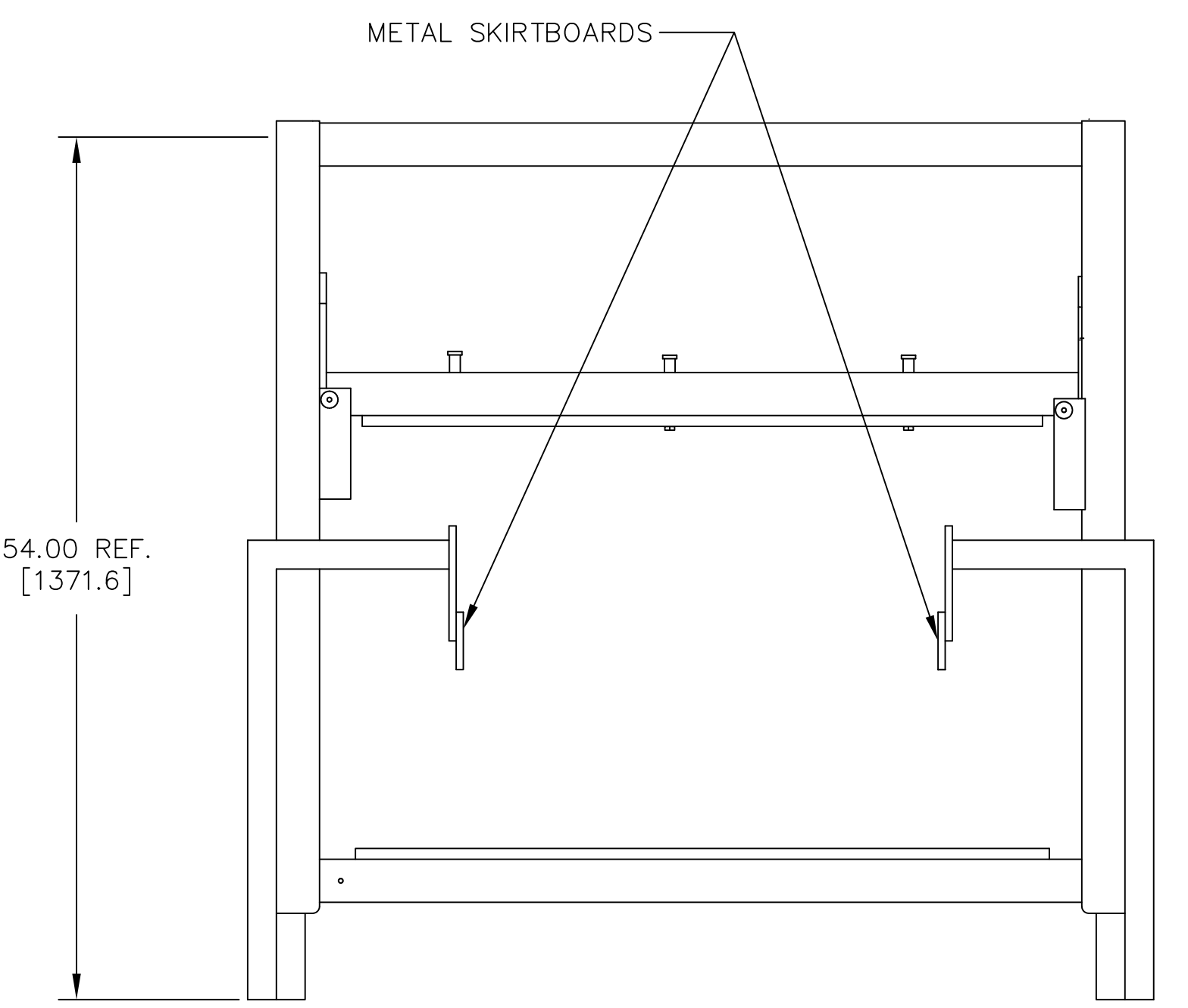
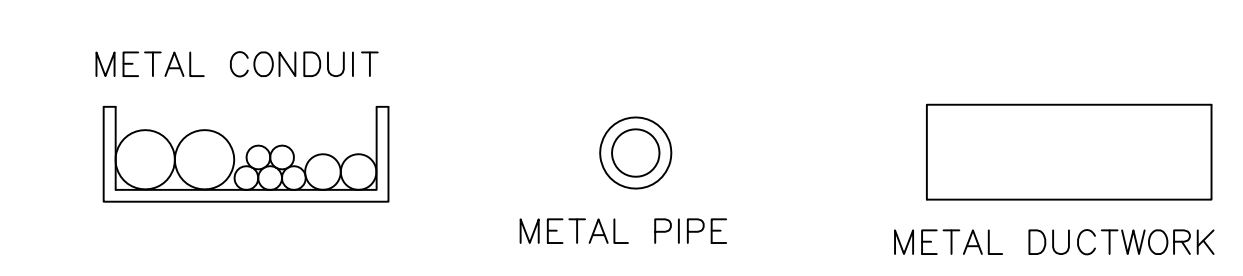
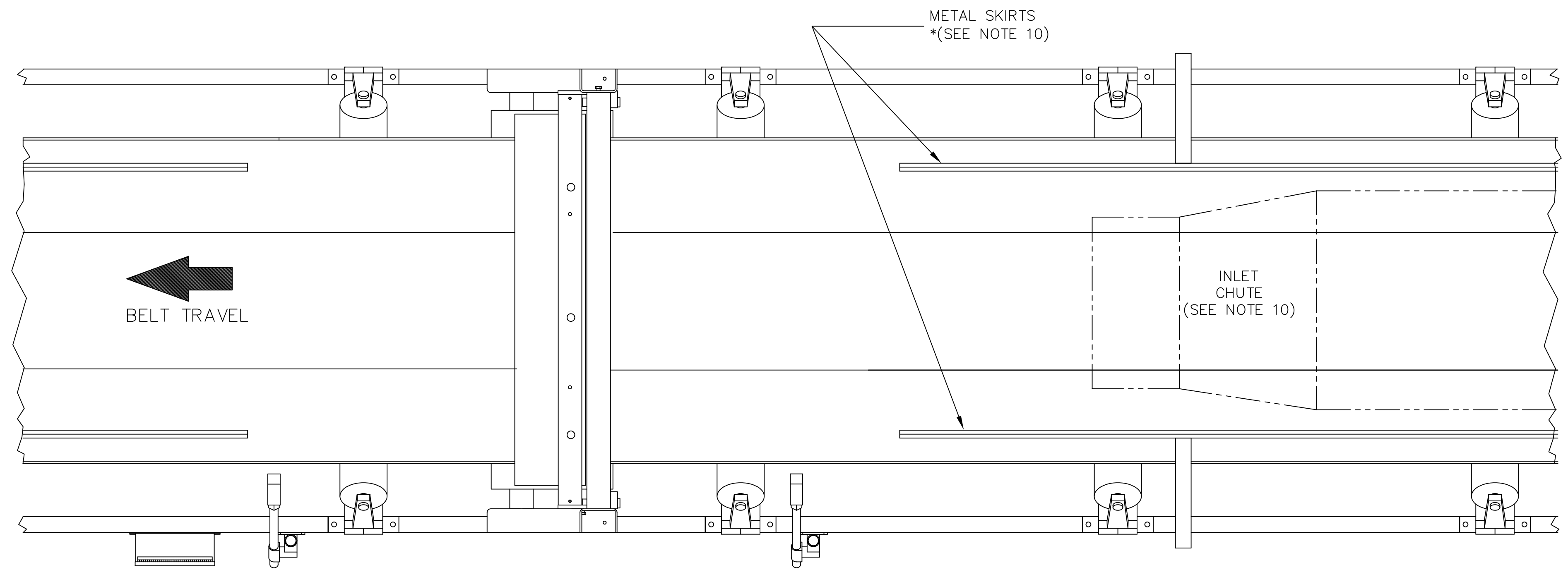

VIEW A-A

SEE NOTES ON SHEET 1 OF 2

METAL PIPE, CONDUIT (SEE NOTE 10)

METAL PIPE, CONDUIT (SEE NOTE 10)

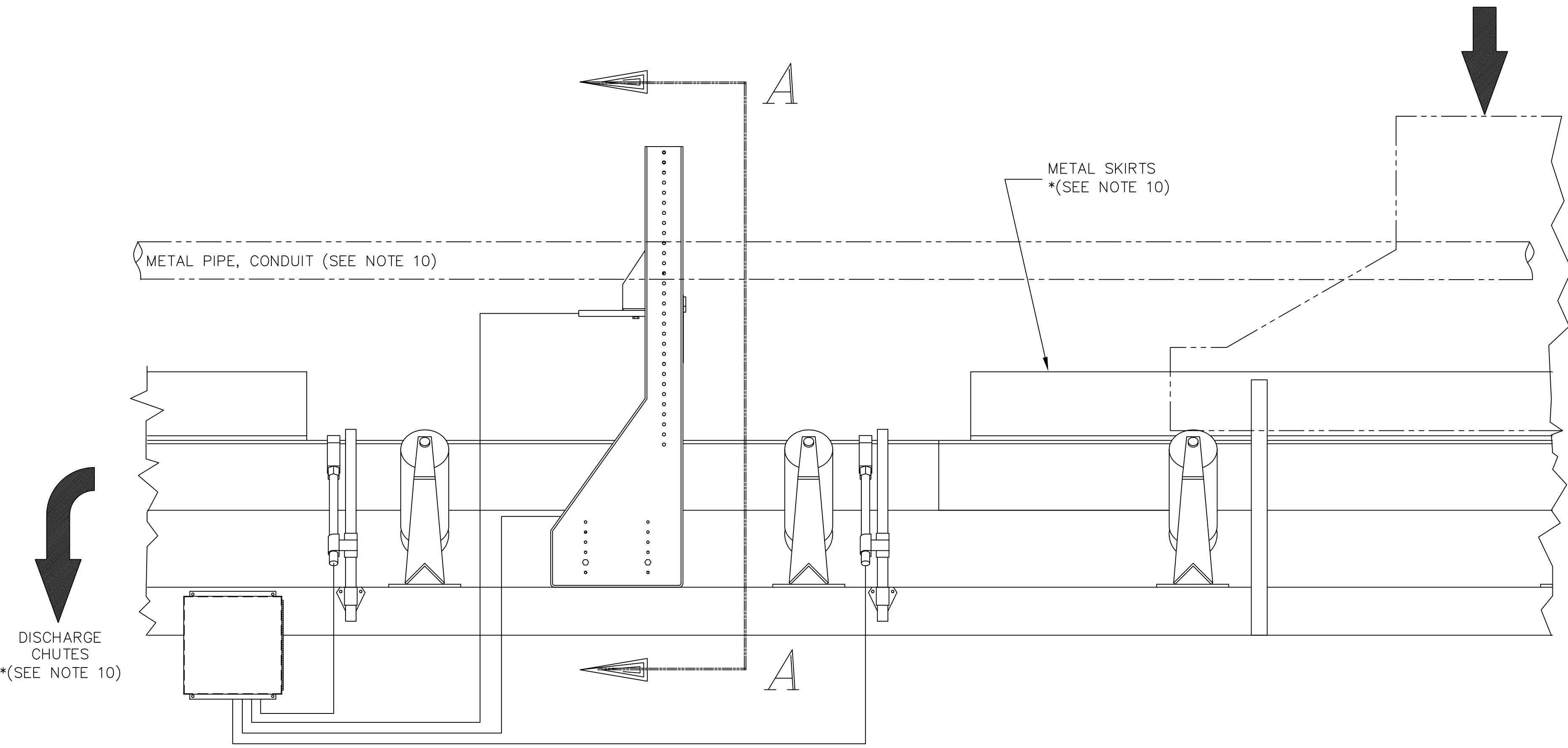

CADD DATABASE: AUTOCAD

DO NOT SCALE DWG	SCALE	N/A
REMOVE ALL BURRS AND UNNECESSARY SHARP EDGES	JOB NO	
TOLERANCE UNLESS SPECIFIED	ENG RWT	DATE 1/25/00
.X ± .06	DWN	DATE 1/25/00
.XX ± .03	KIM	DATE 1/25/00
.XXX ± .01	CHK	DATE 6/13/00
FRACT. ± 1/16	RWT	
ANGLES ± 1/2°		

This document is confidential and is the property of Thermo Fisher Scientific. It may not be copied or reproduced in any way without the expressed written consent of Thermo Fisher Scientific. This document also is an unpublished work of Thermo Fisher Scientific. Thermo Fisher Scientific intends to and is maintaining the work as confidential information. Thermo Fisher Scientific also may seek to protect this work as an unpublished copyright. In the event of other industrial or database publications, Thermo Fisher Scientific intends to enforce its right to this work under the copyright laws as a published work. Those having access to this work may not copy, use or disclose the information in this work unless expressly authorized by Thermo Fisher Scientific.

ThermoFisher
SCIENTIFIC

INSTALLATION PLACEMENT
ORETRONIC III TRAMP METAL DETECTOR
STANDARD SYSTEM, NEMA 4
SHEET 2 OF 2

NEXT ASS'Y	
CUST ORDER NO	
CUSTOMER LOCATION	
USER LOCATION	

PART NO	DRAWING NUMBER	REV
D07328C-A002		C

REV	ECO NO	MICRO	DESCRIPTION	DATE	BY	APPD
			SEE SHEET 1 OF 2			

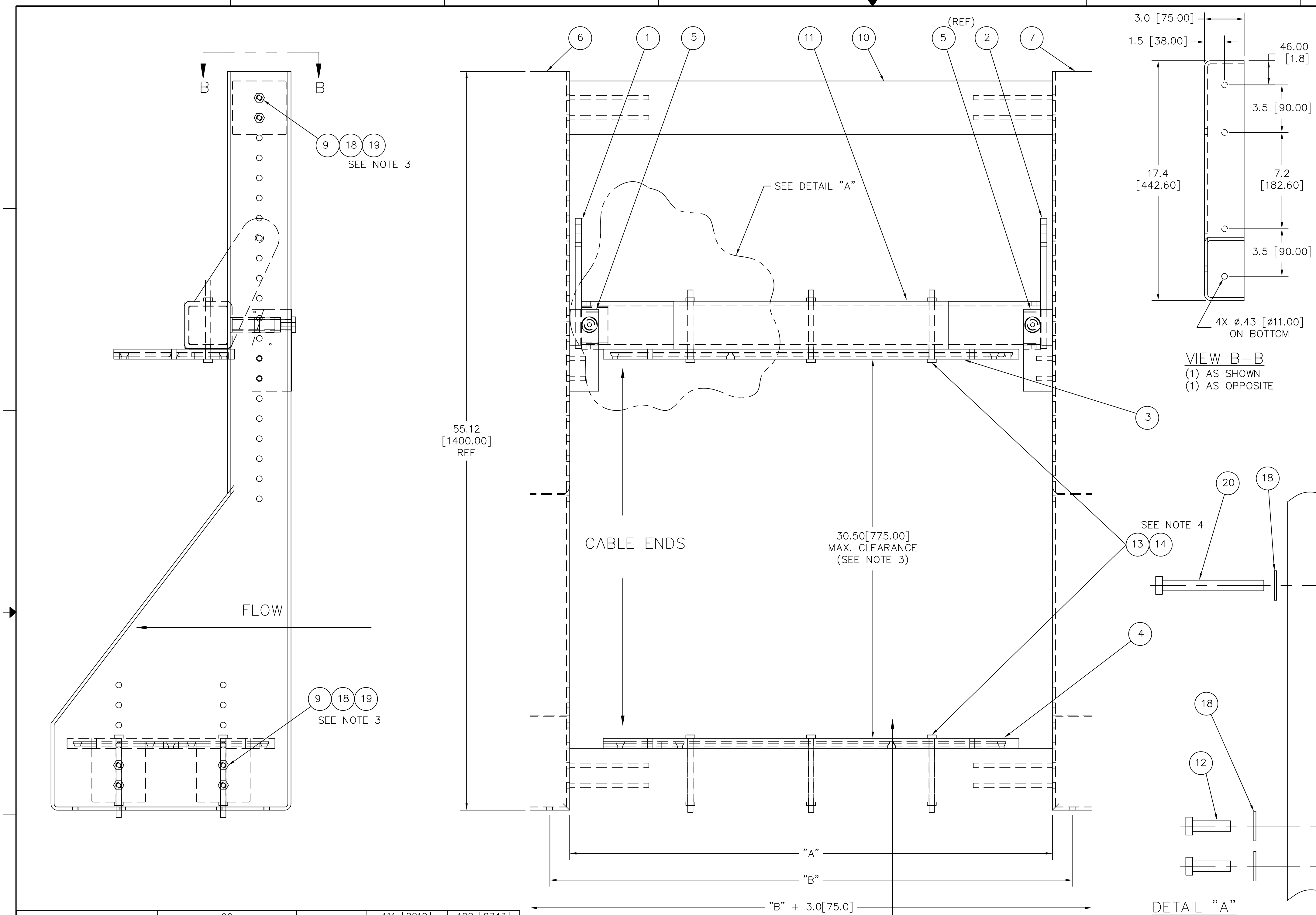

ITEM	PART NO	QTY	DESCRIPTION	DWG NO/SPEC
1	066104	1	BRKT, SWING ARM, TMD III, RH	D07328C-C003
2	066105	1	BRKT, SWING ARM, TMD III, LH	D07328C-C004
3	.	REF	COIL, PL, XMTR	D07328C-C005-XX
4	.	REF	COIL, PL, RCVR	D07328C-C006-XX
5	067219	1 SET	STOP ASSY KIT, STD HDW, ORE III	B07328C-C018/C019
6	066106	1	BRKT, SIDE, TMD III, STD, RH END	D07328C-C008
7	066107	1	BRKT, SIDE, TMD III, STD, LH END	D07328C-C009
8
9	013851	12	SCR, LAG, HEX, 3/8 x 6.00 ZN	.
10	.	1 SET	SPRT, COIL, TMD III	D07328C-C015-XX
11	.	1	BEAM, SWING, ORE III	D07328C-C022-XX
12	005315	4	SCR, CAP, HEX, 3/8-16X1.25 ZN	.
13	066101	9	SCR, CAP, HEX, 1/5-13X 5.0 FGL	.
14	066097	9	NUT, HEX, 1/2-13 GRY FBRGL	.
15	022598	2	BRG, CYL, FLG, .38 x .62 x .75	.
16	066528	2	SCR, CAP, HEX, 5, 3/8-16 x 4.5	.
17	003149	4	NUT, LOCK, N, 5, 3/8-16 FULL ZN	.
18	003129	20	WASHER, FLAT, 3/8 ZN	.
19	003125	16	WASHER, LOCK, SPRING, 3/8 ZN	.
20	005317	2	SCR, CAP, HEX, 5, 3/8-16 x 2.00	.

VIEW B-B
 (1) AS SHOWN
 (1) AS OPPOSITE

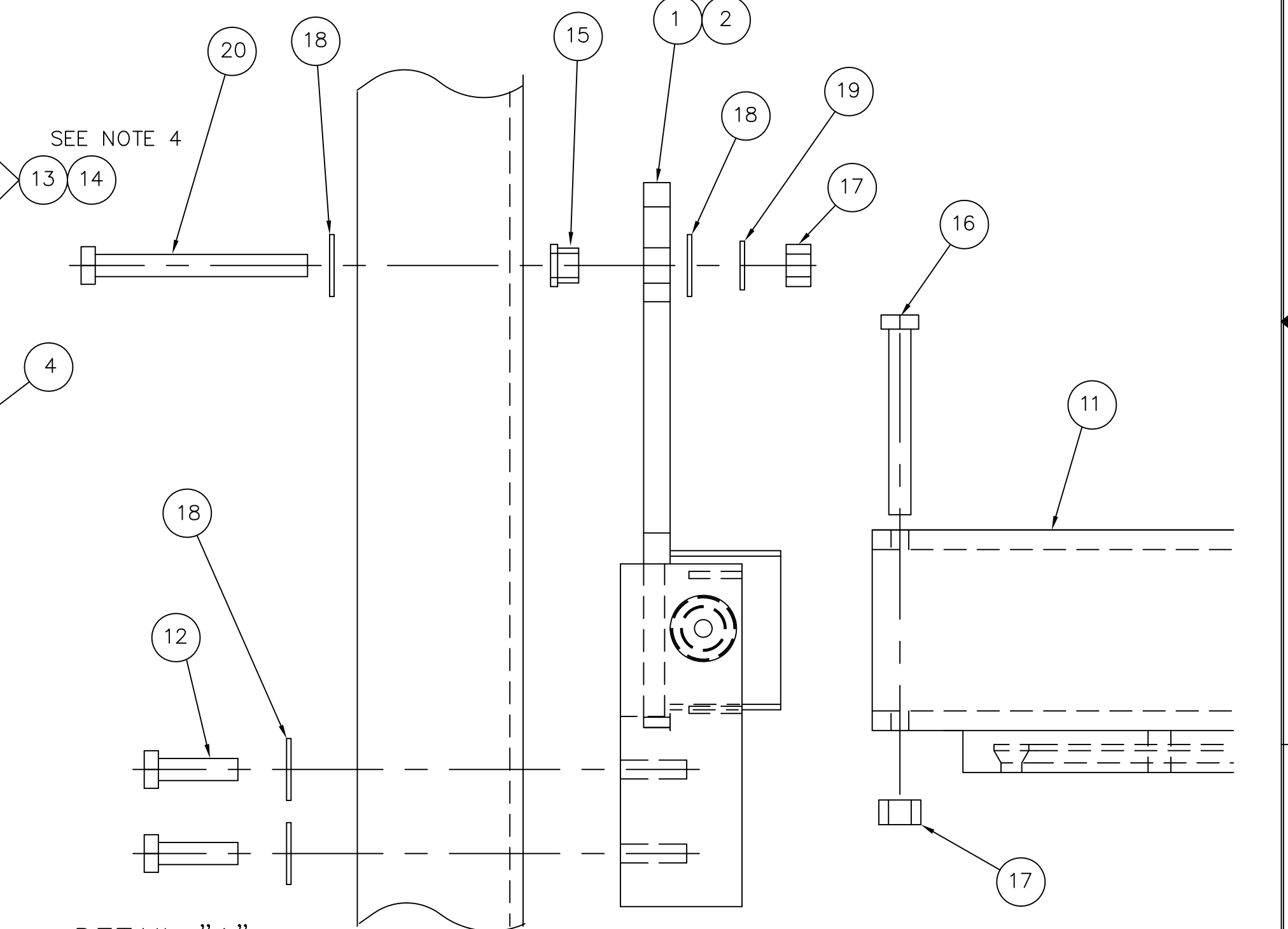

DETAIL "A"
 SCALE: 1:2
 TYP (2) PLACES

- NOTES:
1. READ ALL NOTES BEFORE STARTING ASSEMBLY.
 2. ADJUST TRANSMITTER COIL DEPTH TO GIVE CLEARANCE FOR MAXIMUM BURDEN DEPTH.
 3. TORQUE NOT TO EXCEED 23 N/M [200 IN. LBS.]
 4. TORQUE NOT TO EXCEED 9 N/M [80 IN. LBS.]
 5. DIMENSIONS ARE IN INCHES AND [MILLIMETERS].
 6. TORQUE NOT TO EXCEED 100 IN. OZ.

U.S. BELT + 9 INCHES STD. BELT WIDTH	U.S. BELT + 15 INCHES WIDE BASE B.W.	METRIC BELT	"B" DIM	"A" DIM
96	84	1800 mm	87.38 [2219]	84.38 [2143]
84	72	1600 mm	87 [2210]	84 [2134]
72	60	1400 mm	81 [2057]	78 [1981]
60	54	1200 mm	76 [1930]	73 [1854]
54	48	1050 mm	75 [1905]	72 [1829]
48	42	900 mm	69 [1753]	66 [1676]
42	36	750 mm	68.12 [1730]	65.12 [1654]
36	30	600 mm	63 [1600]	60 [1524]
30	24	500 mm	58.62 [1489]	55.62 [1413]
24	20	450 mm	57 [1448]	54 [1372]
20	18		52.75 [1340]	47.75 [1264]
18			51 [1295]	48 [1219]
			46.88 [1191]	43.88 [1114]
			45 [1143]	42 [1067]
			41 [1041]	38 [965]
			39 [991]	36 [914]
			33 [838]	30 [762]
			29 [737]	26 [660]
			27 [686]	24 [610]

REV	ECO NO	MICRO	DESCRIPTION	DATE	BY	APPD
E	2180		CORRECT LOGO	4-21-10	RAE	RAE
D	0854		FORMAT CHANGE	6/10/05	LB	RWT
C	2441		MISC.	11-16-00	JB	CLB
B	2233		MISC CHANGES TO B/M ADDED FLOW	8/23/00	RDI	RWT
A			RELEASED	6/13/00	KIM	RWT

DO NOT SCALE DWG
 REMOVE ALL BURRS AND UNNECESSARY SHARP EDGES

SCALE 1 : 4
 JOB NO

TOLERANCE UNLESS SPECIFIED
 X ± 1.5 mm .06 in
 XX ± 0.8 mm .03 in
 XXX ± 0.3 mm .01 in
 FRACT ± .50° -1/16
 ANGLES ± .50° -1/2"

ENG LOC DATE 2-21-00
 DWN DATE 2-21-00
 TBP DATE 2-21-00
 CHK DATE 2-21-00
 LOC

ThermoFisher SCIENTIFIC

OUTLINE, MOUNTING AND ASSEMBLY COIL STAND TRAMP METAL DETECTOR

PART NO D07328C-A003
 DRAWING NUMBER
 REV E

ITEM	PART NO	QTY	DESCRIPTION	DWG NO/SPEC
------	---------	-----	-------------	-------------

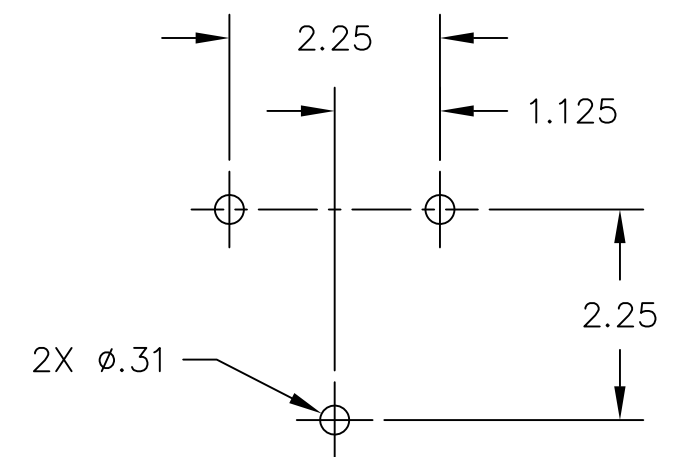

DETAIL "A"
MOUNTING HOLES

INSTALLATION NOTES

1. CLIP DETECTOR TO BE INSTALLED 2" TO 4" BEHIND FIRST IDLER UPSTREAM OF COILS. IF TWO CLIP DETECTORS ARE USED, SECOND UNIT SHOULD BE INSTALLED 2" TO 4" BEHIND FIRST IDLER DOWNSTREAM.
2. DRILL HOLES IN CONVEYOR STRINGER USING MOUNTING FLANGE AS A TEMPLATE. MOUNT CLIP DETECTOR ON STRINGER USING MACHINE SCREWS.
3. SET ANGLE OF CLIP DETECTOR THE SAME AS THE ANGLE OF THE TROUGH IDLER, AND TIGHTEN SET SCREWS WHEN PROPER ANGLE IS ACHIEVED.
4. ADJUST THE CLIP DETECTOR HORIZONTALLY AND VERTICALLY FOR THE 1/2" MAXIMUM DISTANCE FROM THE CONVEYOR BELT. SENSOR HEAD MUST INSTALLED AND ADJUSTED SO THAT IT IS PARALLEL TO THE BELT IN BOTH DIRECTIONS.

HARDWARE:

- 1A) SENSOR HEAD
- 2A) SENSOR SUPPORT SHAFT
- 3A) SWIVEL FITTING
- 4A) VERTICAL SUPPORT SHAFT
- 5A) MOUNTING FLANGE
- 6A) MOUNTING SCREWS

- 3 EA. 1/4-20 x 1.00 LNG. FLH MACH SCR
- 3 EA. 1/4" SPRING LOCK WASHER
- 3 EA. 1/4" FLAT WASHER
- 3 EA. 1/4-20 HEX NUT

(* HARDWARE NOTED ABOVE IS SUPPLIED BY THERMO)

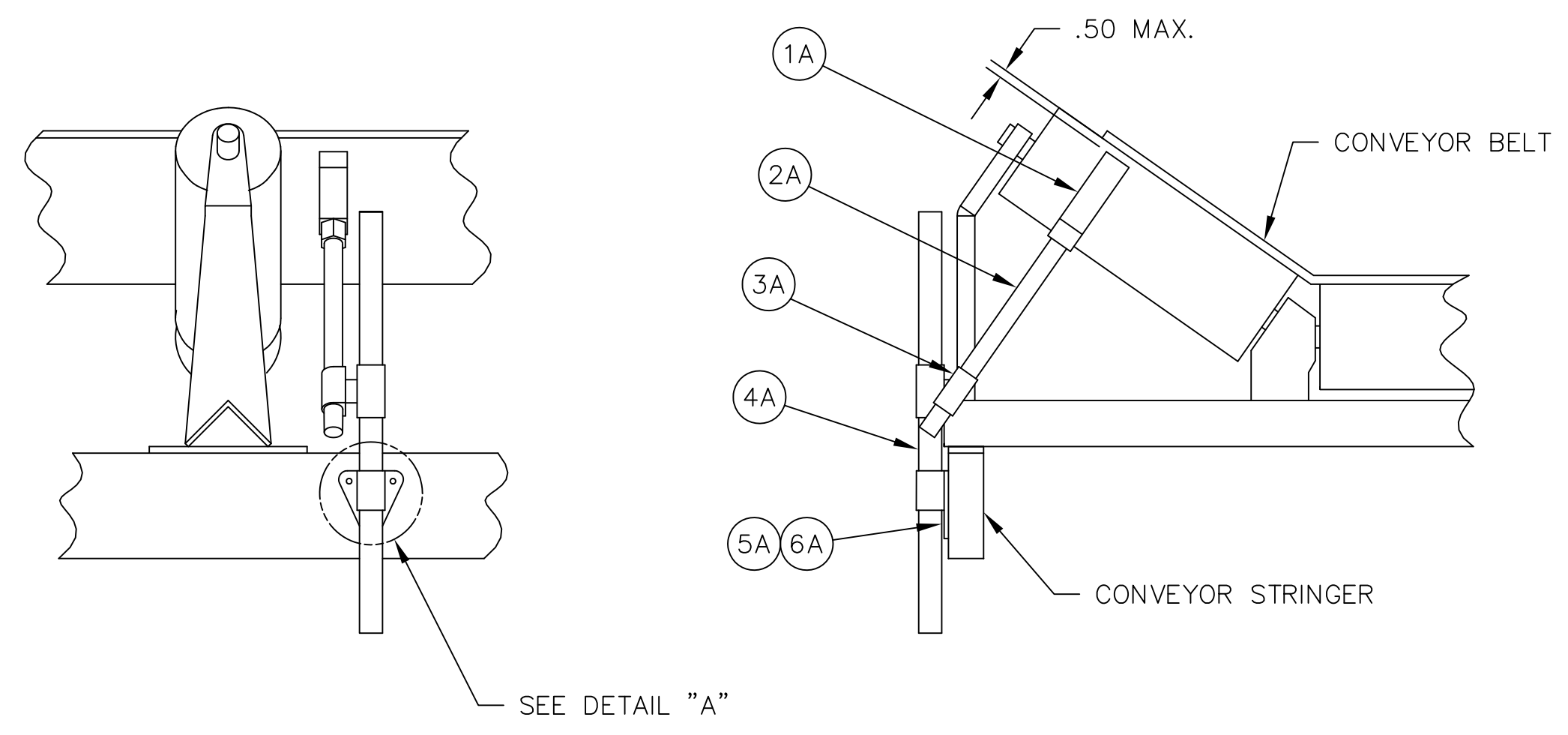

SEE DETAIL "A"

CADD DATABASE: AUTOCAD

DO NOT SCALE DWG REMOVE ALL BURRS AND UNNECESSARY SHARP EDGES		SCALE N/A	
		JOB NO	
TOLERANCE UNLESS SPECIFIED		ENG RWT	DATE 1/25/00
.X	± .06	DWN	DATE 1/25/00
.XX	± .03	KIM	DATE 1/25/00
.XXX	± .01	CHK	DATE 6/13/00
FRACT.	± 1/16	RWT	
ANGLES	± 1/2"		
NEXT ASS'Y			
CUST ORDER NO			
CUSTOMER LOCATION			
USER LOCATION			

This document is confidential and is the property of Thermo Fisher Scientific. It may not be copied or reproduced in any way without the expressed written consent of Thermo Fisher Scientific. This document also is an unpublished work of Thermo Fisher Scientific. Thermo Fisher Scientific intends to and is maintaining the work as confidential information. Thermo Fisher Scientific also may seek to protect this work as an unpublished copyright. In the event of either inadvertent or deliberate publication, Thermo Fisher Scientific intends to enforce its right to this work under the copyright laws as a published work. Those having access to this work may not copy, use or disclose the information in this work unless expressly authorized by Thermo Fisher Scientific.

ThermoFisher
SCIENTIFIC

OUTLINE & MOUNTING DIMENSIONS
CLIP DETECTOR, NEMA 4
ORETRONIC III TRAMP METAL DETECTOR

PART NO	DRAWING NUMBER	REV
	C07328C-B003	C

REV	ECO NO	MICRO	DESCRIPTION	DATE	BY	APPD
C	2180		CORRECT LOGO	4-21-10	RAE	RAE
B	0854		FORMAT CHANGE	6/10/05	LB	RWT
A	2233		RELEASED	6/13/00	KIM	RWT

ITEM	PART NO	QTY	DESCRIPTION	DWG NO/SPEC
------	---------	-----	-------------	-------------

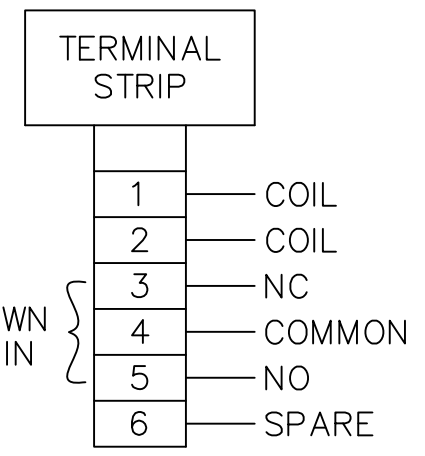
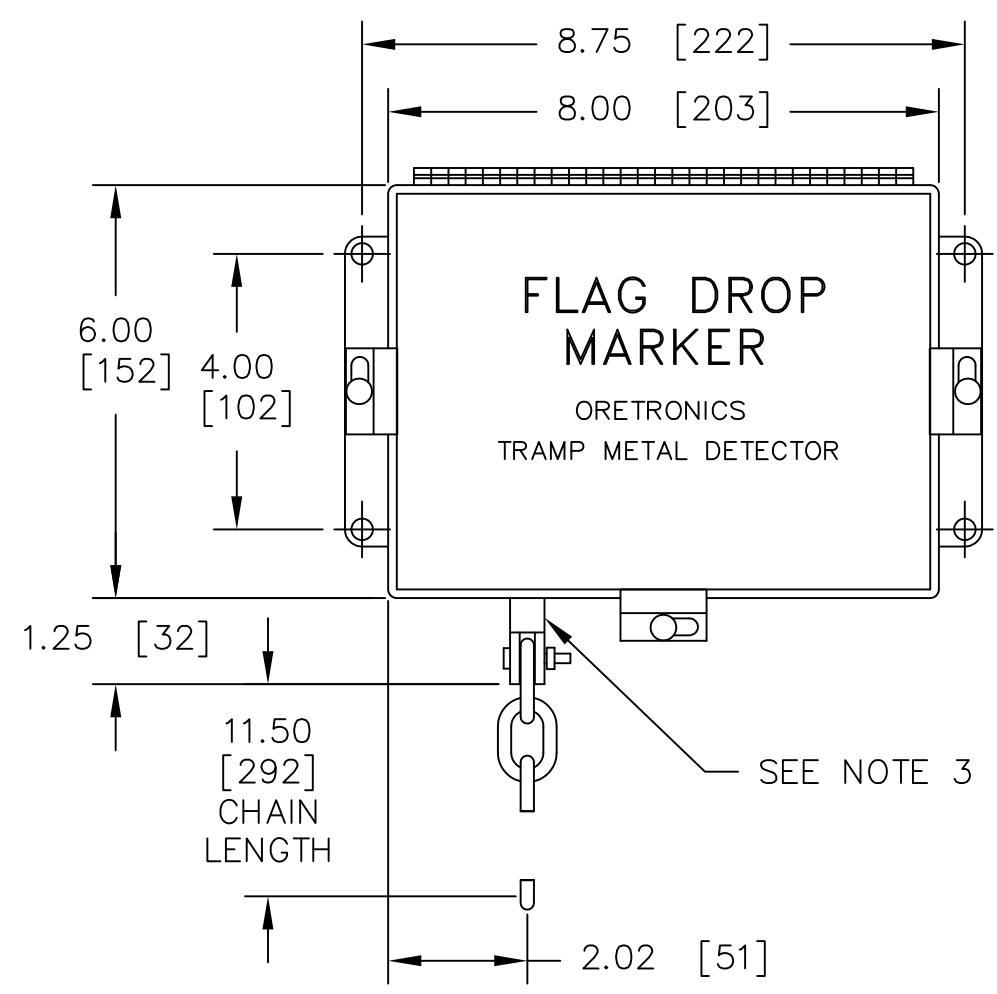

NOTE:

- ENCLOSURE IS 3.50 DEEP, NEMA 4.
- FLAG STATUS CONTACT RATED 10 AMP ± 115 VAC.
- FLAG/CHAIN ASSEMBLY LOCATED 1.75" IN FROM FRONT OF BOX AND 2.02 IN FROM LEFT SIDE.
- DIMENSIONS ARE INCHES AND [mm].
- FLAG DROP MARKER TO BE LOCATED DOWN STREAM OF AND WITHIN 10 SECONDS OF COIL STRUCTURE BUT NOT CLOSER THAN 3 FEET. UNIT TO BE CENTERED OVER BELT AND ABOVE HIGHEST BURDEN DEPTH. (STRUCTURE BY OTHERS)

CADD DATABASE: AUTOCAD

DO NOT SCALE DWG REMOVE ALL BURRS AND UNNECESSARY SHARP EDGES		SCALE NONE	
		JOB NO	
TOLERANCE UNLESS SPECIFIED		ENG RWT	DATE 1/25/00
.X	± .06	DWN KIM	DATE 1/25/00
.XX	± .03	CHK RWT	DATE 6/13/00
.XXX	± .01		
FRACT.	± 1/16		
ANGLES	± 1/2°		
NEXT ASS'Y			
CUST ORDER NO			
CUSTOMER LOCATION			
USER LOCATION			

This document is confidential and is the property of Thermo Fisher Scientific. It may not be copied or reproduced in any way without the expressed written consent of Thermo Fisher Scientific. This document also is an unpublished work of Thermo Fisher Scientific. Thermo Fisher Scientific intends to and is maintaining the work as confidential information. Thermo Fisher Scientific also may seek to protect this work as an unpublished copyright. In the event of either inadvertent or deliberate publication, Thermo Fisher Scientific intends to enforce its right to this work under the copyright laws as a published work. Those having access to this work may not copy, use or disclose the information in this work unless expressly authorized by Thermo Fisher Scientific.



OUTLINE & MOUNTING DIMENSIONS
FLAG DROP MARKER, NEMA 4
ORETRONIC III TRAMP METAL DETECTOR

REV	ECO NO	MICRO	DESCRIPTION	DATE	BY	APPD
D	2180		CORRECT LOGO	4-20-10	RAE	RAE
C	0854		FORMAT CHANGE	6/10/05	LB	RWT
B	2877		COMPANY NAME CHANGE	10/2/01	KIM	RWT
A	2233		RELEASED	6/13/00	KIM	RWT

PART NO	DRAWING NUMBER	REV
	B07328C-B004	D

VERSION	PART NO.	DESCRIPTION	ITEM 1 PART NO.
-01	057037	SPRAY MARKER ASSY, TMD, 115 VAC	013617
-02	057038	SPRAY MARKER ASSY, TMD, 230 VAC	034894

ITEM	PART NO	QTY	DESCRIPTION	DWG NO/SPEC
1	SEE TAB	1 EA	VALVE,3-WAY,2POSN,AIR,EP	
2	013618	2 EA	HOSE ASSY,AIR,10'X1/4 X1/4F	
3	013619	1 EA	HOSE ASSY,FL,10'X3/8F X3/8F	
4	057043	1 EA	TANK,2 GALLON,PRESSURE W/DBL REGULATOR	
5	013621	1 EA	EXTRACTOR,OIL & WATER,1/2NPT	
6	057041	1 EA	STRAINER,INLINE,3/8FPS X3/8MPS	
7	057040	1 EA	SPRAY GUN,HEAVY DUTY,AUTOMATIC	
8	057042	1 EA	STUD,MTG,SPRAY GUN,AUTOMATIC	
9	001002	1 EA	FTG,PIPE,BRS,NIP,RDCG, 1/2-1/4	
10	037840	3 EA	FTG,PIPE,NIP,CLOSE,HEX, 1/4NPT	
11	013430	1 EA	FTG,PIPE,TEE, 1/4NPT	
12	002583	1 EA	FTG,PIPE,COUPLING, 1/4 NPTF	
13	057039	1 EA	CLAMP,MTG.,SPRAY GUN, AUTOMATIC	

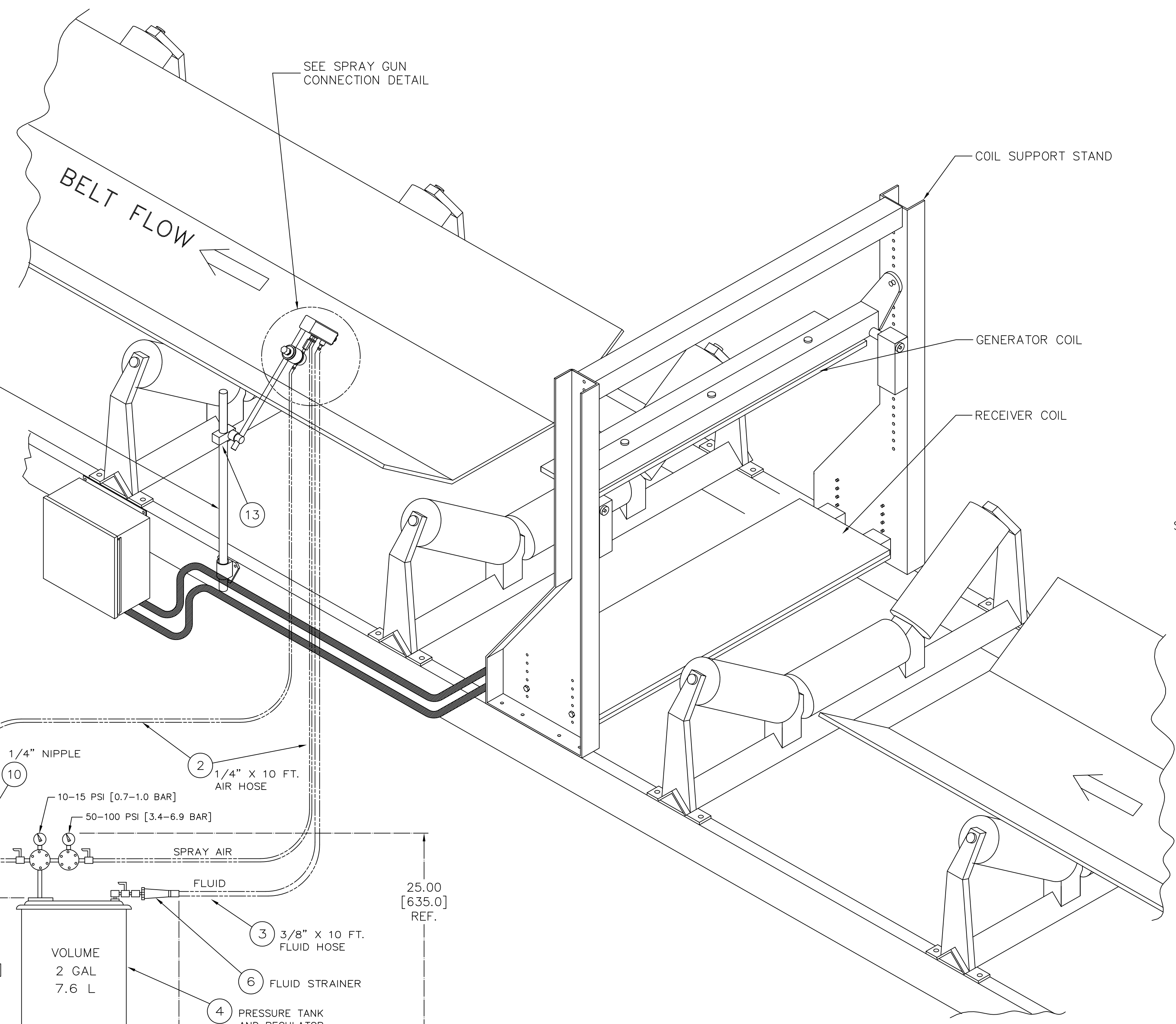

NOTES:

- FOR MARKING FLUID USE EITHER:

MIXTURE OF APPROXIMATELY EIGHT (8) OUNCES (250 ml) OF PAINT TINTER OR COLORANT AND ONE GALLON OF 50-50 COMBINATION OF WATER AND ANTIFREEZE.

MIXTURE OF DYE RHODOMINE B AND A 50-50 COMBINATION OF WATER AND ANTI-FREEZE (ADD A CONSIDERABLE AMOUNT OF RHODOMINE B TO GIVE SUFFICIENT COLOR).
- MATERIALS NOT SUPPLIED BY THERMO:
1) BRACKET SUPPORT AND METAL PLATE.
- DIMENSIONS ARE INCHES AND [mm].

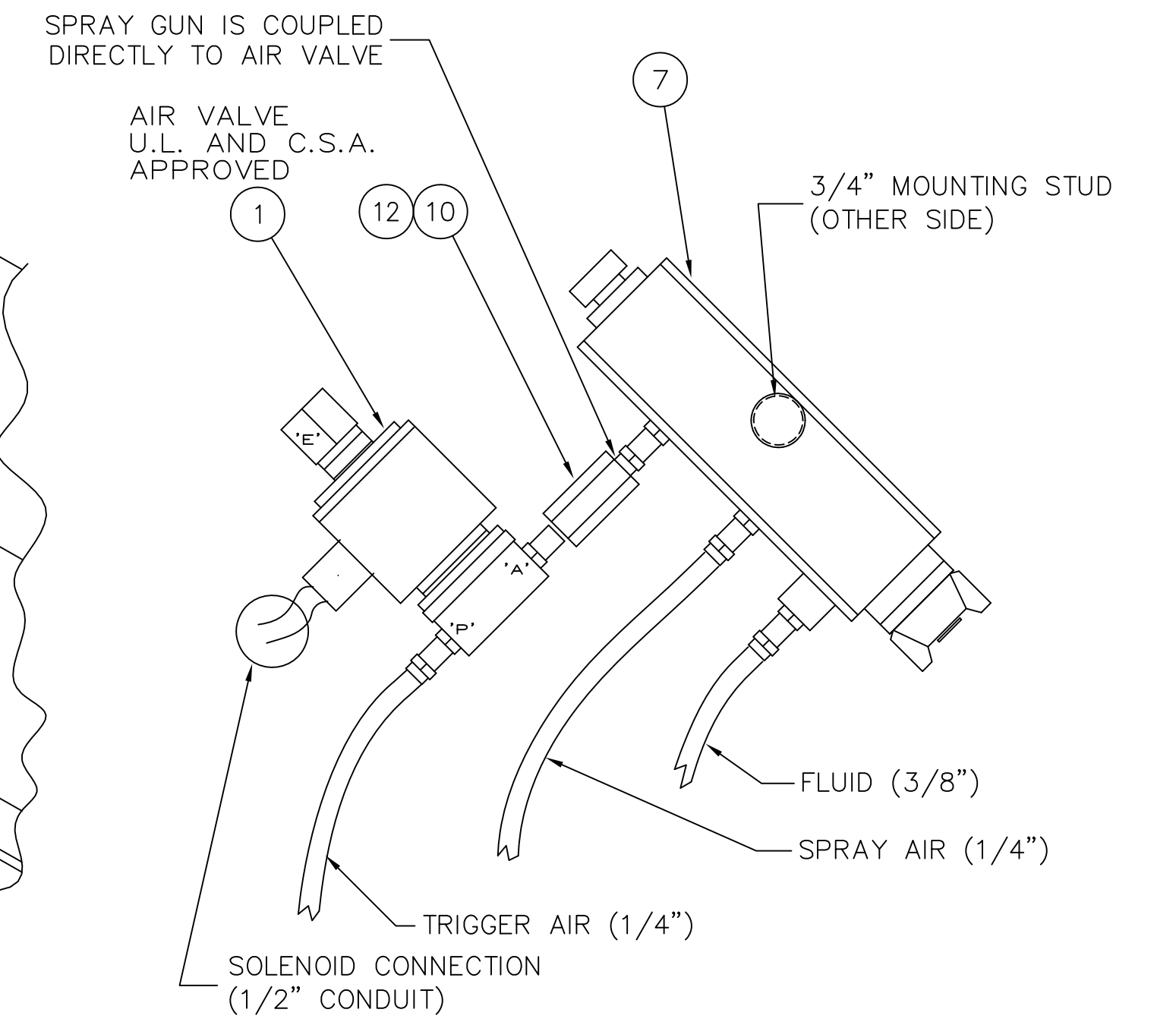

GUN CONNECTION DETAIL

SHIPPING WEIGHTS

TANK: 66.0 LBS
 SPRAY GUN: 4.0 LBS (WITH SOLENOID)

C	2180	CORRECT LOGO	4-21-10	RAE	RAE
B	0672	FORMAT CHANGE	6/08/05	LE	RWT
A	2233	RELEASED	6/14/00	KIM	RWT
REV	ECO NO	MICRO	DESCRIPTION	DATE	BY
					APFD

CADD DATABASE: AUTOCAD

DO NOT SCALE DWG	SCALE N/A	This document is confidential and is the property of Thermo Fisher Scientific. It may not be copied or reproduced in any way without the expressed written consent of Thermo Fisher Scientific. This document also is an unpublished work of Thermo Fisher Scientific. Thermo Fisher Scientific intends to and is maintaining the work as confidential information. Thermo Fisher Scientific also may seek to protect this work as an unpublished copyright. In the event of other industrial or scientific publications, Thermo Fisher Scientific intends to enforce its right to this work under the copyright laws as a published work. Those having access to this work may not copy, use or disclose the information in this work unless expressly authorized by Thermo Fisher Scientific.
REMOVE ALL BURRS AND UNNECESSARY SHARP EDGES	JOB NO	
TOLERANCE UNLESS SPECIFIED	ENG RWT DATE 1/31/00	<p>OUTLINE & MOUNTING DIMENSIONS SPRAY MARKER ASSEMBLY NEMA 4 & 9, ORETRONIC III TRAMP METAL DETECTOR</p>
.x ± .06	OWN DATE 1/31/00	
.xx ± .03	KIM DATE 6/14/00	
.xxx ± .01	CHK RWT DATE 6/14/00	
FRACT ± 1/16		
ANGLES ± 1/2°		
NEXT ASS'Y		
CUST ORDER NO		
CUSTOMER LOCATION		
USER LOCATION		
SEE TAB D	07344B-B007-XX	C

Derived From 007080B-0001-XX

© - Jy Thermo Fisher Scientific

ITEM	PART NO	QTY	DESCRIPTION	DWG NO/SPEC
1	SEE TAB	1 EA.	HORN, ALARM, WTHPRF, 120V OR 240V	

NOTES:

- 3/4-14 NPT HOLE ON TOP, BOTTOM AND REAR.
- WEATHERPROOF ASSEMBLY
- DIMENSIONS ARE INCHES AND [mm].

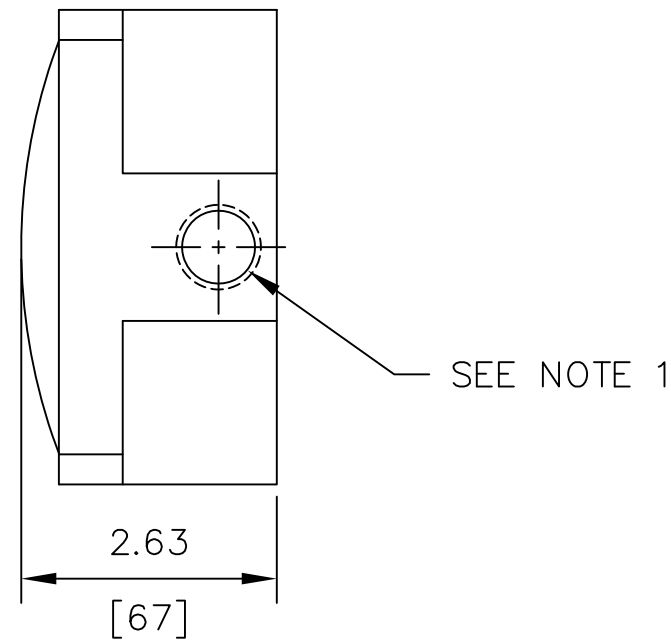
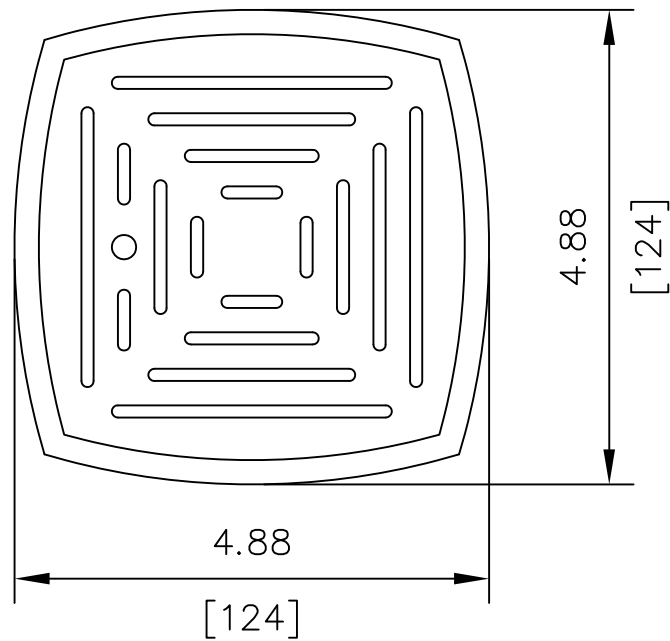

034890	HORN,ALARM,WTHPRF TYPE,240V
034889	HORN,ALARM,WTHPRF TYPE,120V
PART NO.	DESCRIPTION

CADD DATABASE: AUTOCAD

DO NOT SCALE DWG REMOVE ALL BURRS AND UNNECESSARY SHARP EDGES		SCALE NONE	
		JOB NO	
TOLERANCE UNLESS SPECIFIED		ENG RWT	DATE 1/27/00
.X	± .06	DWN KIM	DATE 1/27/00
.XX	± .03	CHK RWT	DATE 6/13/00
.XXX	± .01		
FRACT.	± 1/16		
ANGLES	± 1/2°		
NEXT ASS'Y			
CUST ORDER NO			
CUSTOMER LOCATION			
USER LOCATION			

This document is confidential and is the property of Thermo Fisher Scientific. It may not be copied or reproduced in any way without the expressed written consent of Thermo Fisher Scientific. This document also is an unpublished work of Thermo Fisher Scientific. Thermo Fisher Scientific intends to and is maintaining the work as confidential information. Thermo Fisher Scientific also may seek to protect this work as an unpublished copyright. In the event of either inadvertent or deliberate publication, Thermo Fisher Scientific intends to enforce its right to this work under the copyright laws as a published work. Those having access to this work may not copy, use or disclose the information in this work unless expressly authorized by Thermo Fisher Scientific.

ThermoFisher
SCIENTIFIC

OUTLINE & MOUNTING DIMENSIONS
ALARM HORN, NEMA 4, 120V OR 240V
ORETRONIC III TRAMP METAL DETECTOR

PART NO	DRAWING NUMBER	REV
	B 07328C-B005	C

REV	ECO NO	MICRO	DESCRIPTION	DATE	BY	APPD
C	2180		CORRECT LOGO	4-21-10	RAE	RAE
B	0854		FORMAT CHANGE	6/13/05	LB	RWT
A	2233		RELEASED	6/13/00	KIM	RWT

ITEM	PART NO	QTY	DESCRIPTION	DWG NO/SPEC
1	SEE TAB	1	LIGHT,ROTATING BEACON,AMB	

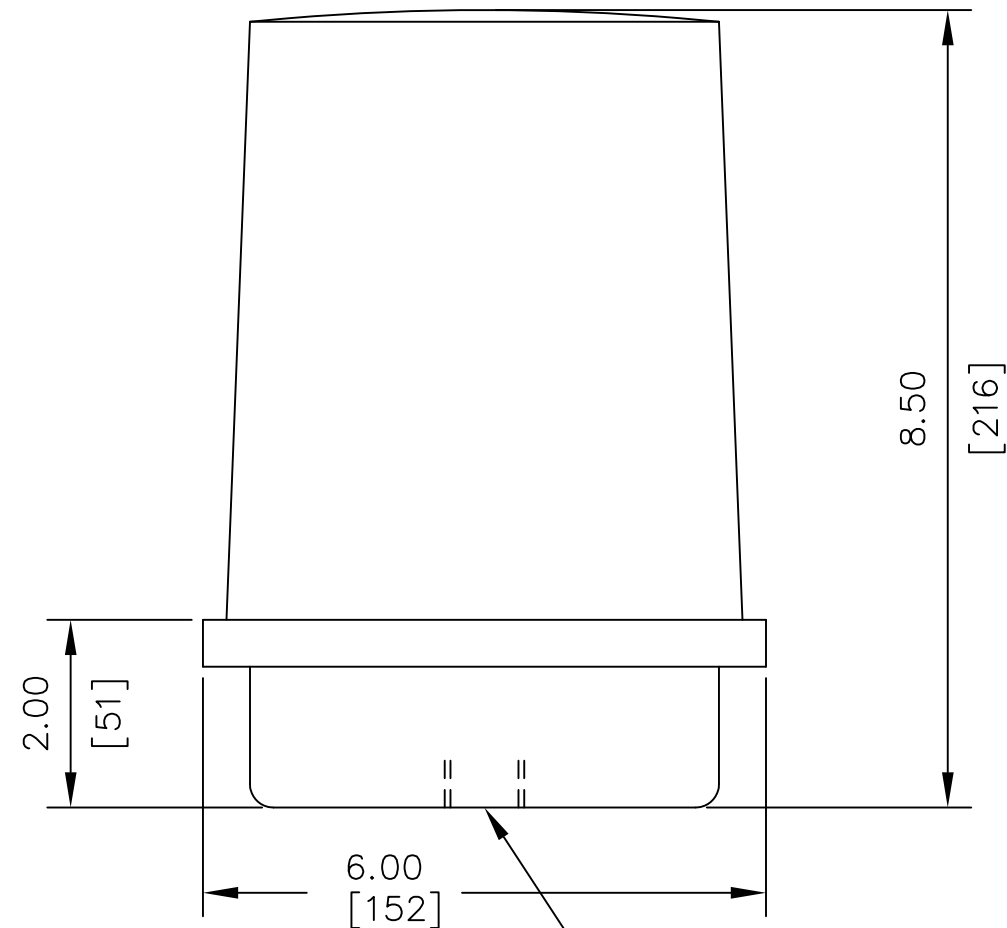

NOTE:

1. 1/2 INCH PIPE THREAD HOLE
2. WEATHERPROOF ASSEMBLY.
3. DIMENSIONS ARE INCHES AND [mm].

057392	LIGHT, ROTATING BEACON, 240VAC
057391	LIGHT, ROTATING BEACON, 120VAC
PART NO.	DESCRIPTION

CADD DATABASE: AUTOCAD

DO NOT SCALE DWG REMOVE ALL BURRS AND UNNECESSARY SHARP EDGES		SCALE NONE	This document is confidential and is the property of Thermo Fisher Scientific. It may not be copied or reproduced in any way without the expressed written consent of Thermo Fisher Scientific. This document also is an unpublished work of Thermo Fisher Scientific. Thermo Fisher Scientific intends to and is maintaining the work as confidential information. Thermo Fisher Scientific also may seek to protect this work as an unpublished copyright. In the event of either inadvertent or deliberate publication, Thermo Fisher Scientific intends to enforce it's right to this work under the copyright laws as a published work. Those having access to this work may not copy, use or disclose the information in this work unless expressly authorized by Thermo Fisher Scientific.	
TOLERANCE UNLESS SPECIFIED		ENG RWT	DATE 2/15/00	<h1>Thermo Fisher SCIENTIFIC</h1> <p>OUTLINE & MOUNTING DIMENSIONS ROTATING BEACON ASSEMBLY NEMA 4 ORETRONIC III TRAMP METAL DETECTOR</p>
.X	± .06	DWN KIM	DATE 2/15/00	
.XX	± .03	CHK RWT	DATE 6/13/00	
.XXX	± .01			
FRACT.	± 1/16			
ANGLES	± 1/2°			

NEXT ASS'Y	
CUST ORDER NO	
CUSTOMER LOCATION	
USER LOCATION	

REV	ECO NO	MICRO	DESCRIPTION	DATE	BY	APPD
C	2180		CORRECT LOGO	4-21-10	RAE	RAE
B	0854		FORMAT CHANGE	6/13/05	LB	RWT
A	2233		RELEASED	6/13/00	KIM	RWT

ITEM	PART NO	QTY	DESCRIPTION	DWG NO/SPEC
------	---------	-----	-------------	-------------

INSTALLATION NOTES

1. MOUNT HIGH PILE SWITCH ASSEMBLY AS SHOWN.
2. BOTTOM OF HIGH PILE SWITCH SHOULD BE 1/4" ABOVE TRANSMITTER COIL.
3. ARM OF SWITCH MUST BE POINTED DOWN IN ALL APPLICATIONS.
4. ADJUST ARM OF SWITCH SO THAT IT JUST CHANGES STATE WHEN SWING ARM ACTUATOR IS AGAINST SIDE BRACKET.
5. DIMENSIONS ARE INCHES AND [mm].

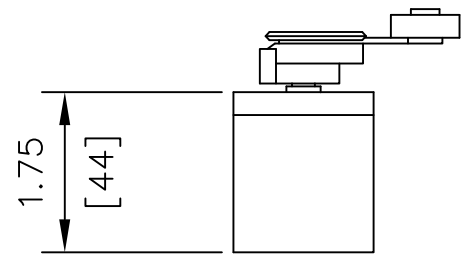
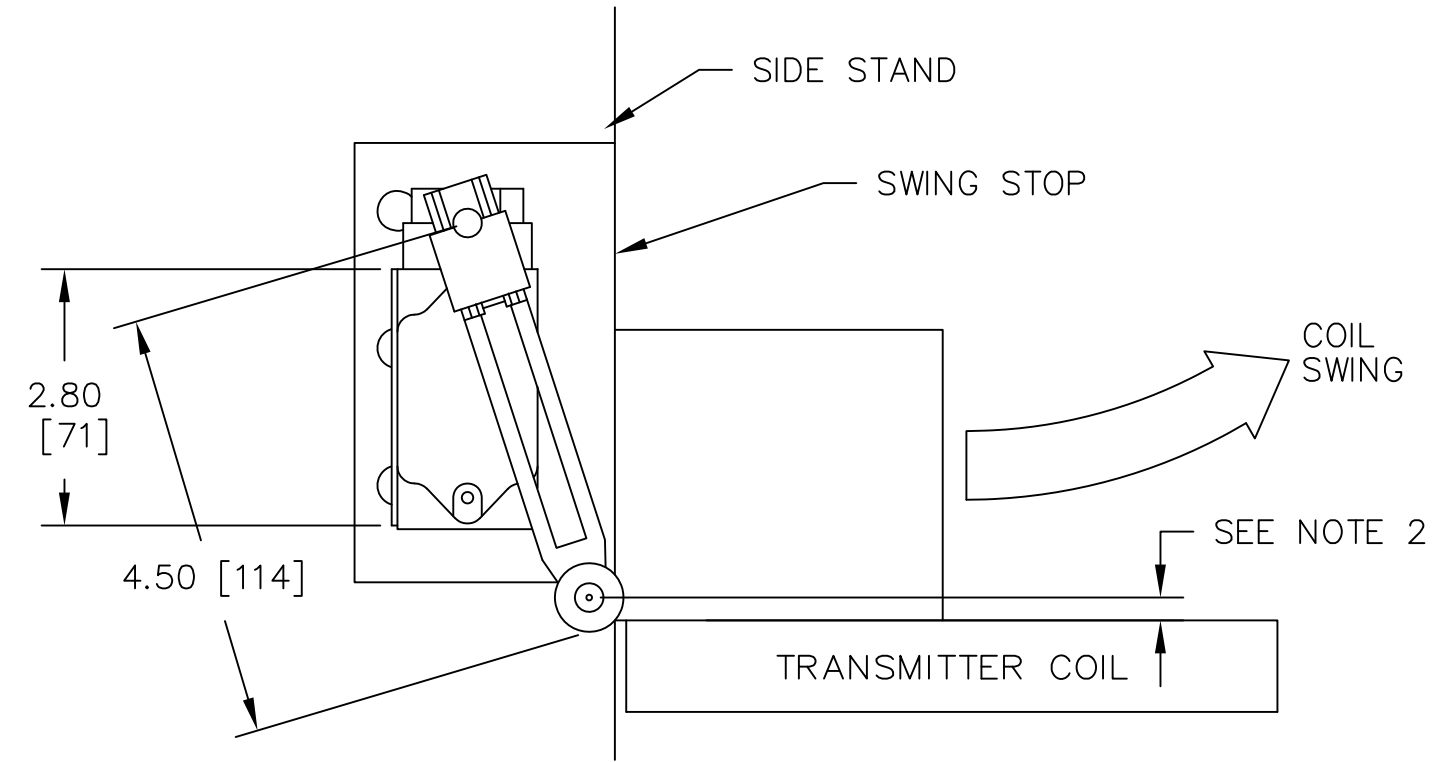

CADD DATABASE: AUTOCAD

DO NOT SCALE DWG REMOVE ALL BURRS AND UNNECESSARY SHARP EDGES		SCALE N/A	
		JOB NO	
TOLERANCE UNLESS SPECIFIED		ENG RWT	DATE 1/27/00
.X	± .06	DWN KIM	DATE 1/27/00
.XX	± .03	CHK RWT	DATE 6/13/00
.XXX	± .01		
FRACT.	± 1/16		
ANGLES	± 1/2°		
NEXT ASS'Y			
CUST ORDER NO			
CUSTOMER LOCATION			
USER LOCATION			

This document is confidential and is the property of Thermo Fisher Scientific. It may not be copied or reproduced in any way without the expressed written consent of Thermo Fisher Scientific. This document also is an unpublished work of Thermo Fisher Scientific. Thermo Fisher Scientific intends to and is maintaining the work as confidential information. Thermo Fisher Scientific also may seek to protect this work as an unpublished copyright. In the event of either inadvertent or deliberate publication, Thermo Fisher Scientific intends to enforce its right to this work under the copyright laws as a published work. Those having access to this work may not copy, use or disclose the information in this work unless expressly authorized by Thermo Fisher Scientific.

ThermoFisher SCIENTIFIC

OUTLINE, MOUNTING & INSTALLATION
HIGH PILE DETECTOR, NEMA 4
ORETRONIC III TRAMP METAL DETECTOR

PART NO	DRAWING NUMBER	REV
	B07328C-B007	C

REV	ECO NO	MICRO	DESCRIPTION	DATE	BY	APPD
C	2180		CORRECT LOGO	4-21-10	RAE	RAE
B	0854		FORMAT CHANGE	6/13/05	KIM	RWT
A	2233		RELEASED	6/13/00	KIM	RWT

Derived From B07080A-R003

© 2000 ,by Thermo Fisher Scientific

ITEM	PART NO	QTY	DESCRIPTION	DWG NO/SPEC
1	068380	1 EA	COIL PL,EST,ORETRONIC III	D07328C-K003
2	068382	SEE TAB	COIL, FORMED, EST ORE III	B07328C-K005
3	068044	SEE TAB	PCBA,EST RELAY,ORETRONIC III	B07328C-E141
4	009711	15.0 FT	CABLE,SHLD,BRD, 2/C 22AWG	
5	065850	42 OZ	EPOXY,CASTING(1121-A),RESIN	
6	065851	42 OZ	EPOXY,CASTING(1121-B),HARDENER	
7				
8				
9	013592	AS REQ	ADHESIVE,HOT MELT (1942)	
10	068383	2 EA	SCR,CAP,HEXFLG,1/2-13X 6.0 FGL	
11	068384	4 EA	WASHER,PVC,FLAT,.50 X1.5000D	
12	066097	2 EA	NUT,HEX, 1/2-13 GRY FBRGL	
13	005800	1 EA	BAG,ANTI-STATIC,2MIL, 9 X 12	
14	006000	1 EA	WIRE,SOLID TINNED COPPER,18AWG	
15	062827	SEE TAB	WIRE,UL RCGD,#22(7X30)WHT	9.50" LONG
16	068268	SEE TAB	WIRE,UL RCGD,#22(7X30)BLK	9.50" LONG
17	066831	20 EA	CLIP,COIL,XMTR/RCVR,ORE III	B07328C-E022

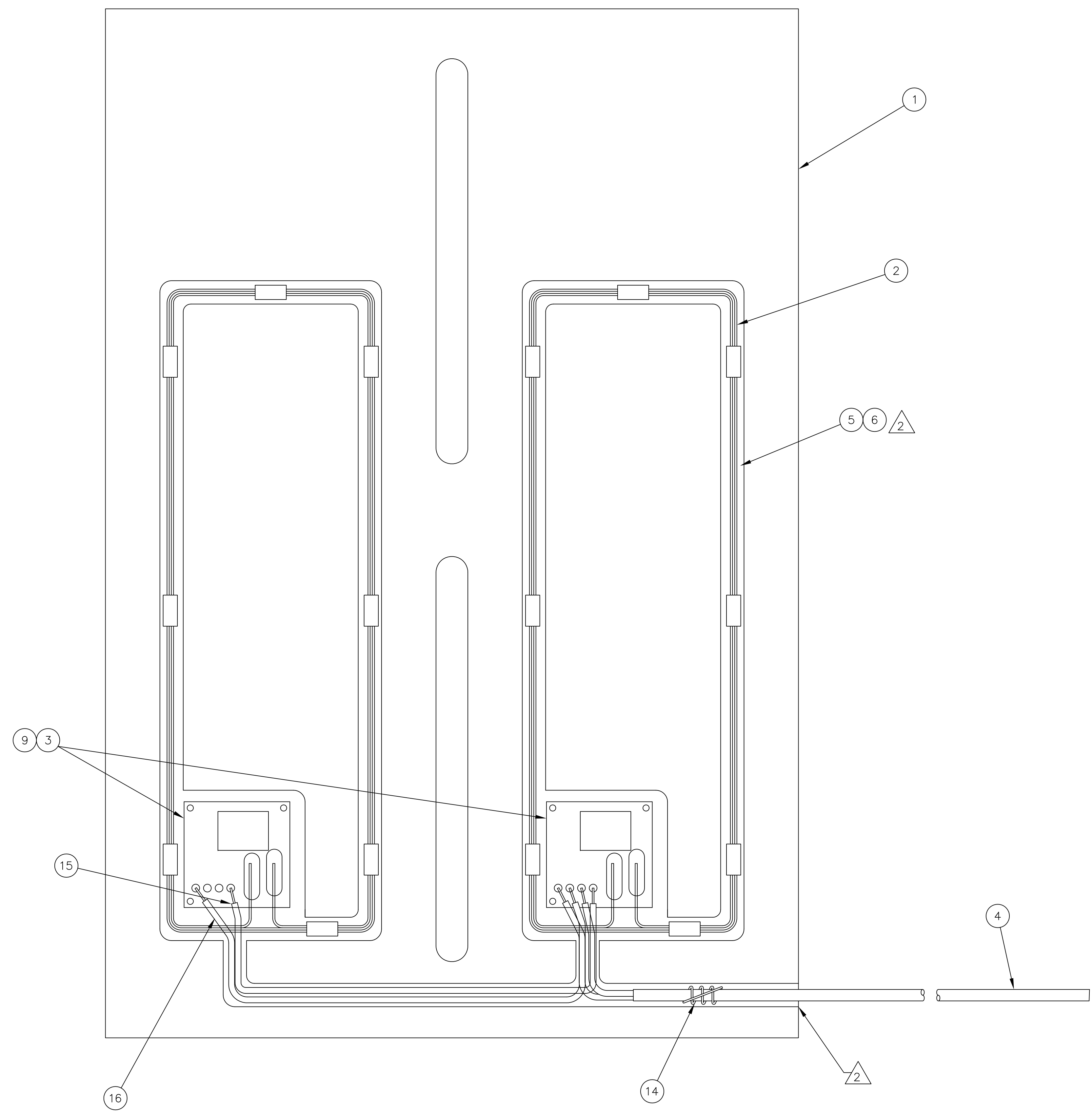

NOTES:

- PLACE PCBA (ITEM 3) INTO POCKET IN PLATE (ITEM 1) AND PLACE COIL (ITEM 2) INTO GROOVE. SECURE COIL WITH COIL CLIPS (ITEM 17) AS REQUIRED.
- SOLDER COIL (ITEM 2) TO PADS ON PCBA (ITEM 3).
- STRIP 2.5" OF SHIELD FROM ENDS OF CABLE (ITEM 4) TO EXPOSE BLACK AND WHITE WIRES. CUT OFF SHIELD. STRIP BACK BLACK AND WHITE WIRES .25" AND SOLDER TO PCBA. BLACK TO PAD LABELED BLACK AND WHITE TO PAD LABELLED CLEAR.
- IF BUILDING A TWO COIL SYSTEM, USING BLACK WIRE (ITEM 16) TIE FIRST PCBA BLACK TO SECOND PCBA BLACK. USING WHITE WIRE (ITEM 15), TIE FIRST PCBA WHITE TO SECOND PCBA WHITE.
- WRAP THE WIRE (ITEM 14) AROUND THE CABLE (ITEM 4), THEN TWIST THE ENDS TOGETHER, TO SERVE AS A STRAIN RELIEF.
- USE A SMALL AMOUNT OF HOT MELT ADHESIVE (ITEM 9) ON TWO CORNERS TO SECURE PCBA (ITEM 3) TO COIL PLATE (ITEM 1).
- SEAL CAVITY END AROUND CABLE WITH HOT MELT (ITEM 9).
- FILL GROOVE WITH EPOXY (ITEM 5 & 6) LEAVING THE LED EXPOSED.
- PLACE SCREWS (ITEM 10), WASHERS (ITEM 11) AND NUTS (ITEM 12) INTO POLY BAG (ITEM 13) AND SECURE TO COIL PLATE (ITEM 1) WITH TAPE.

VERSION	PART NO.	DESCRIPTION	QTY.	QTY.	QTY.	QTY.
			ITEM 2	ITEM 3	ITEM 15	ITEM 16
-02	068379	HIGH STRENGTH	2	2	.79 FT	.79 FT
-01	068378	STANDARD	1	1	0	0

REV	ECO NO	MICRO	DESCRIPTION	DATE	BY	APPD
D	2180		CORRECT LOGO	4-21-10	RAE	RAE
C	2850		ADD ITEM 17, CHG NOTES, QTY OF ITEMS 15,16	9/25/01	KIM	RWT
B	2673		CHG TO CABLE OUT LEFT SIDE, ADD DOVETAIL	5/23/01	KIM	RWT
A	2673		RELEASED	2/1/01	LOC	LOC

DO NOT SCALE DWG		SCALE 1/1	
REMOVE ALL BURRS AND UNNECESSARY SHARP EDGES		JOB NO	
TOLERANCE UNLESS SPECIFIED	ENG LOC	DATE	2/1/01
.x ± .06	OWN	DATE	2/1/01
.xx ± .03	LOC	DATE	2/1/01
.xxx ± .01	CHK	DATE	2/1/01
FRACT ± 1/16			
ANGLES ± 1/2°			
NEXT ASS'Y			
CUST ORDER NO			
CUSTOMER LOCATION			
USER LOCATION			

This document is confidential and is the property of Thermo Fisher Scientific. It may not be copied or reproduced in any way without the expressed written consent of Thermo Fisher Scientific. This document also is an unpublished work of Thermo Fisher Scientific. Thermo Fisher Scientific intends to and is maintaining the work as confidential information. Thermo Fisher Scientific also may seek to protect this work as an unpublished copyright. In the event of other industrial or scientific publications, Thermo Fisher Scientific intends to enforce its right to this work under the copyright laws as a published work. Those having access to this work may not copy, use or disclose the information in this work unless expressly authorized by Thermo Fisher Scientific.

Thermo Fisher SCIENTIFIC

MODULE ASSEMBLY
ELECTRONICALLY SIMULATED TRAMP
ORETRONIC III

PART NO	DRAWING NUMBER	REV
SEE TAB	D07328C-K001	D

© 2001 by Thermo Fisher Scientific

ITEM	PART NO	QTY	DESCRIPTION	DWG NO/SPEC
1	REF	2	BRACKET,SIDE, ORETRONIC III	
2	REF	1	COIL,RECEIVER, ORETRONIC III	
3	REF	2	SUPPORT,COIL, ORETRONIC III	
4	SEE TAB	1	COIL,EST, ORETRONIC III	SEE TAB
5	REF	2	SCR,CAP,HEXFLG, 1/2-13 X 6.00 FGL	SUPPLIED WITH EST COIL
6	REF	2	NUT,HEX, 1/2-13 GR Y FBRGL	SUPPLIED WITH EST COIL
7	REF	4	WASHER,PVC,FLAT, .50 X 1.500 OD	SUPPLIED WITH EST COIL

VERSION	ITEM 4	
	DRAWING NUMBER	PART NUMBER
STANDARD EST	D07328C-K001	068378
HIGH STRENGTH EST	D07328C-K002	068379

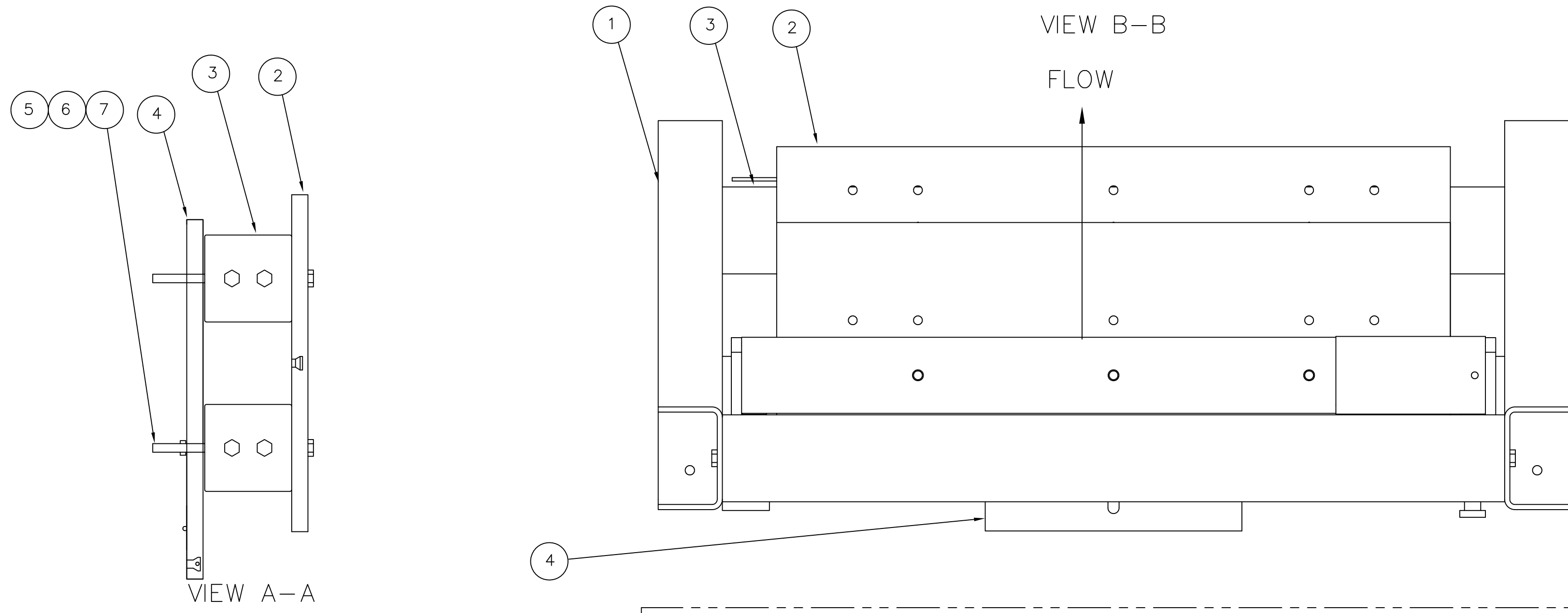

SIDE BRACKETS OF STAND NOT SHOWN FOR CLARITY

1. REMOVE TWO CENTER BOLTS FROM PLATE BY FIRST REMOVING NUT (LOCATED UNDER SUPPORT BEAM). DISCARD BOLTS.
2. POSITION THE EST (ITEM 4) UNIT FACING POTTING SIDE DOWNWARD UNDER SUPPORT BEAM, WITH THE CABLE END TOWARD THE SAME SIDE AS THE CABLE ON THE METAL DETECTOR (ITEM 2)
3. INSERT TWO BOLTS (ITEM 5) PROVIDED WITH EST UNIT, APPLY WASHERS (ITEM 7) , AND NUTS (ITEM 8) AND TIGHTEN.

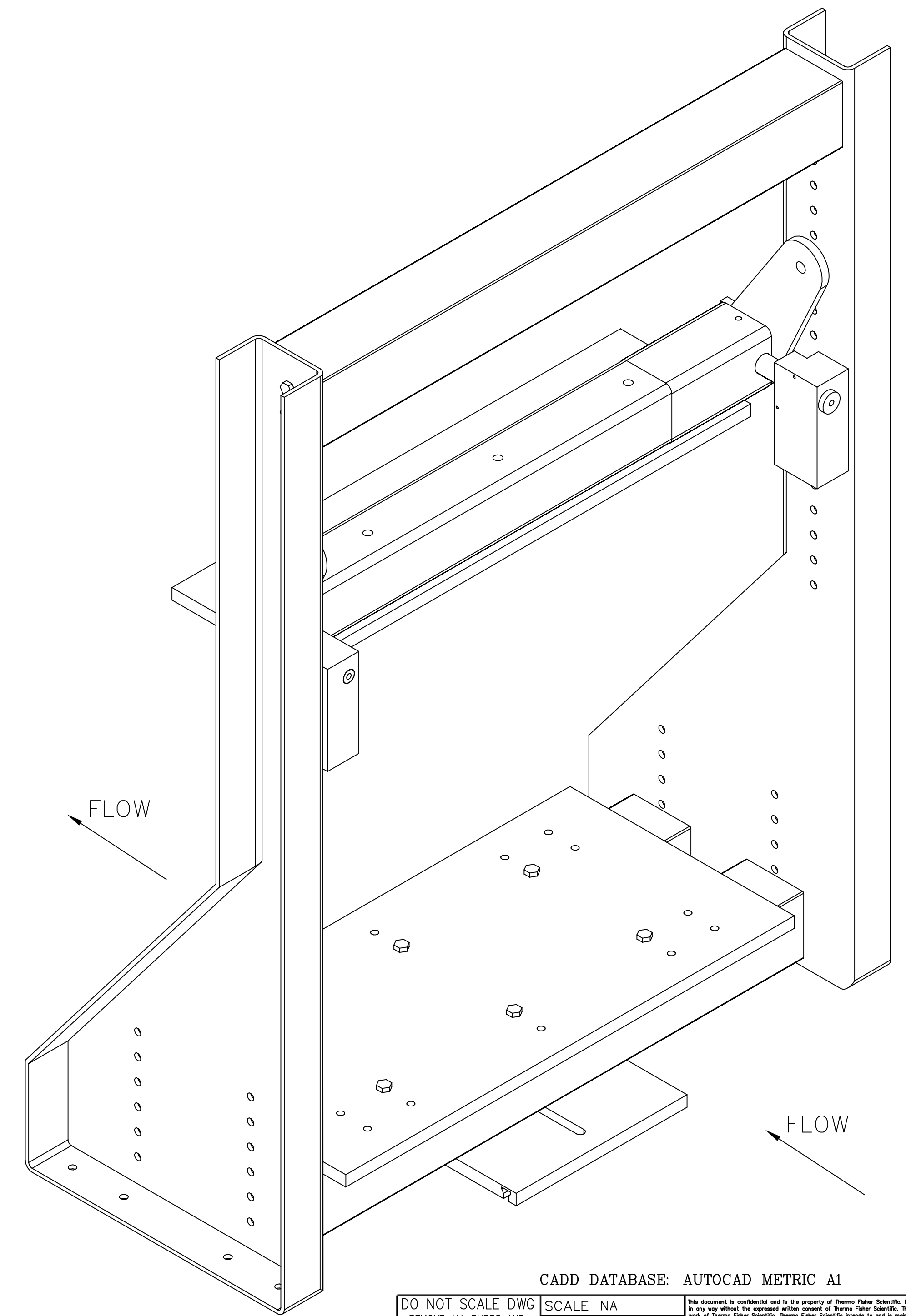
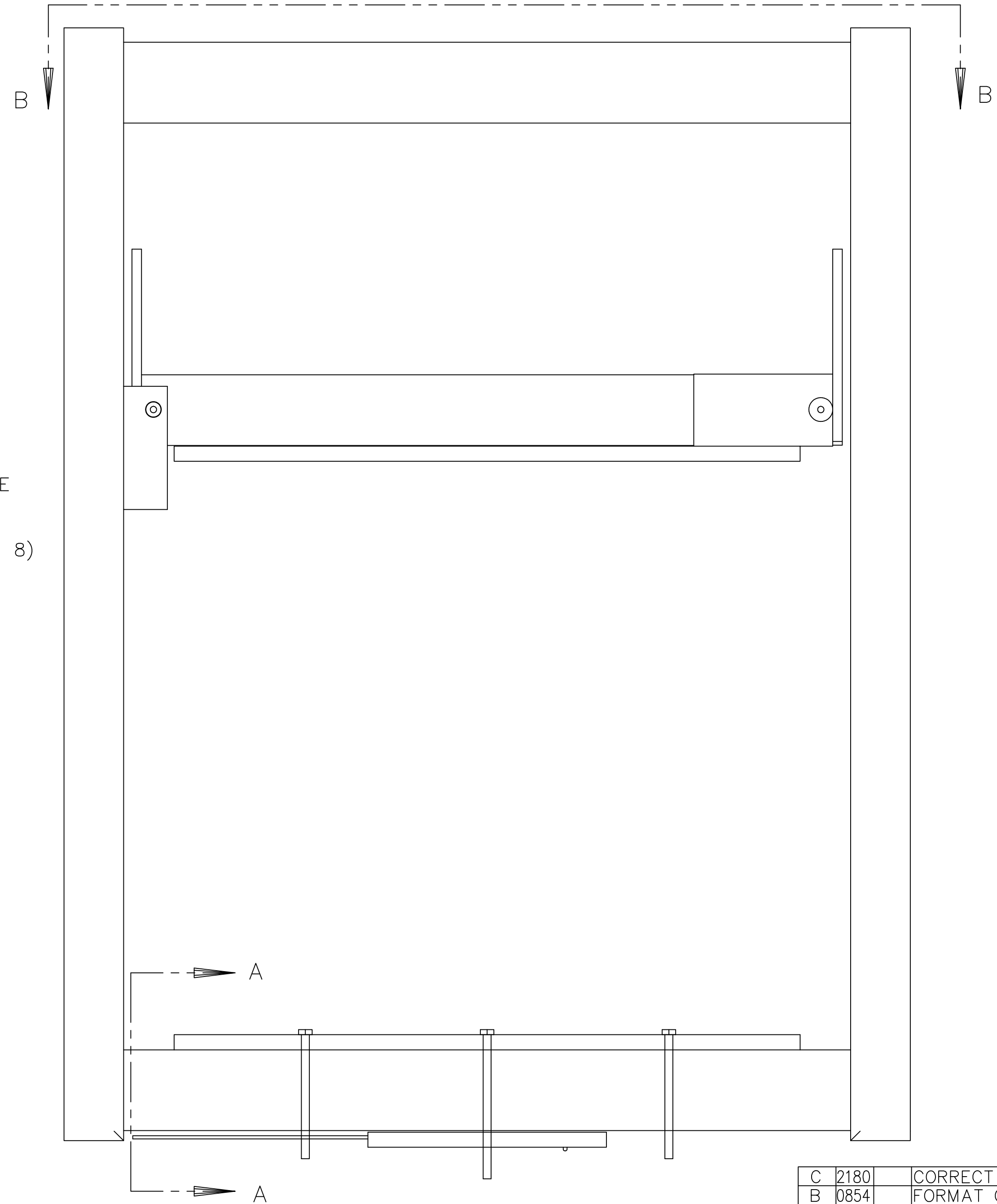

CADD DATABASE: AUTOCAD METRIC A1

DO NOT SCALE DWG		SCALE NA		REMOVE ALL BURRS AND UNNECESSARY SHARP EDGES		JOB NO		<small> This document is confidential and is the property of Thermo Fisher Scientific. It may not be copied or reproduced in any way without the expressed written consent of Thermo Fisher Scientific. This document also is an unpublished work of Thermo Fisher Scientific. Thermo Fisher Scientific intends to and is maintaining the work as confidential information. Thermo Fisher Scientific also may seek to protect this work as an unpublished copyright. In the event of other treatment or subsequent publication, Thermo Fisher Scientific intends to enforce its right in the work under the copyright law as a published work. Those having access to this work may not copy, use or disclose the information in this work unless expressly authorized by Thermo Fisher Scientific. </small>	
TOLERANCE UNLESS SPECIFIED		ENG	LOC	DATE	DATE	LOC	DATE	ThermoFisher SCIENTIFIC	
.X	± 1.5 mm .06 in.	DWN	JLB	4-30-01	DATE	CHK	LOC	4-30-01	OUTLINE, MOUNTING EST TRAMP METAL DETECTOR
.XX	± 0.8 mm .03 in.	DATE	DATE	DATE	DATE	DATE	DATE	DATE	PART NO DRAWING NUMBER REV D07328C-B008 C
.XXX	± 0.3 mm .01 in.	DATE	DATE	DATE	DATE	DATE	DATE	DATE	
FRACT.	± 1/16	DATE	DATE	DATE	DATE	DATE	DATE	DATE	
ANGLES	± .50°	DATE	DATE	DATE	DATE	DATE	DATE	DATE	
NEXT ASS'Y		CUST ORDER NO		CUSTOMER LOCATION		USER LOCATION		APPD	

REV	ECO NO	MICRO	DESCRIPTION	DATE	BY	APPD
C	2180		CORRECT LOGO	4-21-10	RAE	RAE
B	0854		FORMAT CHANGE	6/13/05	LB	RWT
A	2673		RELEASED	4-30-01	JLB	RWT

ITEM	PART NO	QTY	DESCRIPTION	DWG NO/SPEC
1	REF	2	BRACKET,UND BELT, ORETRONIC III	
2	REF	2	SUPPORT,COIL,SGN,ORETRONIC III	
3	REF	1	COIL,SQL SIDED, ORETRONIC III	
4	SEE TAB	1	COIL,EST, ORETRONIC III	
5	REF	2	SCR,CAP,HEXFLG, 1/2-13 X 6.000 FGL	SUPPLIED W/EST COIL
6	REF	2	NUT,HEX, 1/2-13 GRY FBRGL	SUPPLIED W/EST COIL
7	REF	2	WASHED,PVC,FLAT,.50 X 1.500 OD	SUPPLIED W/EST COIL

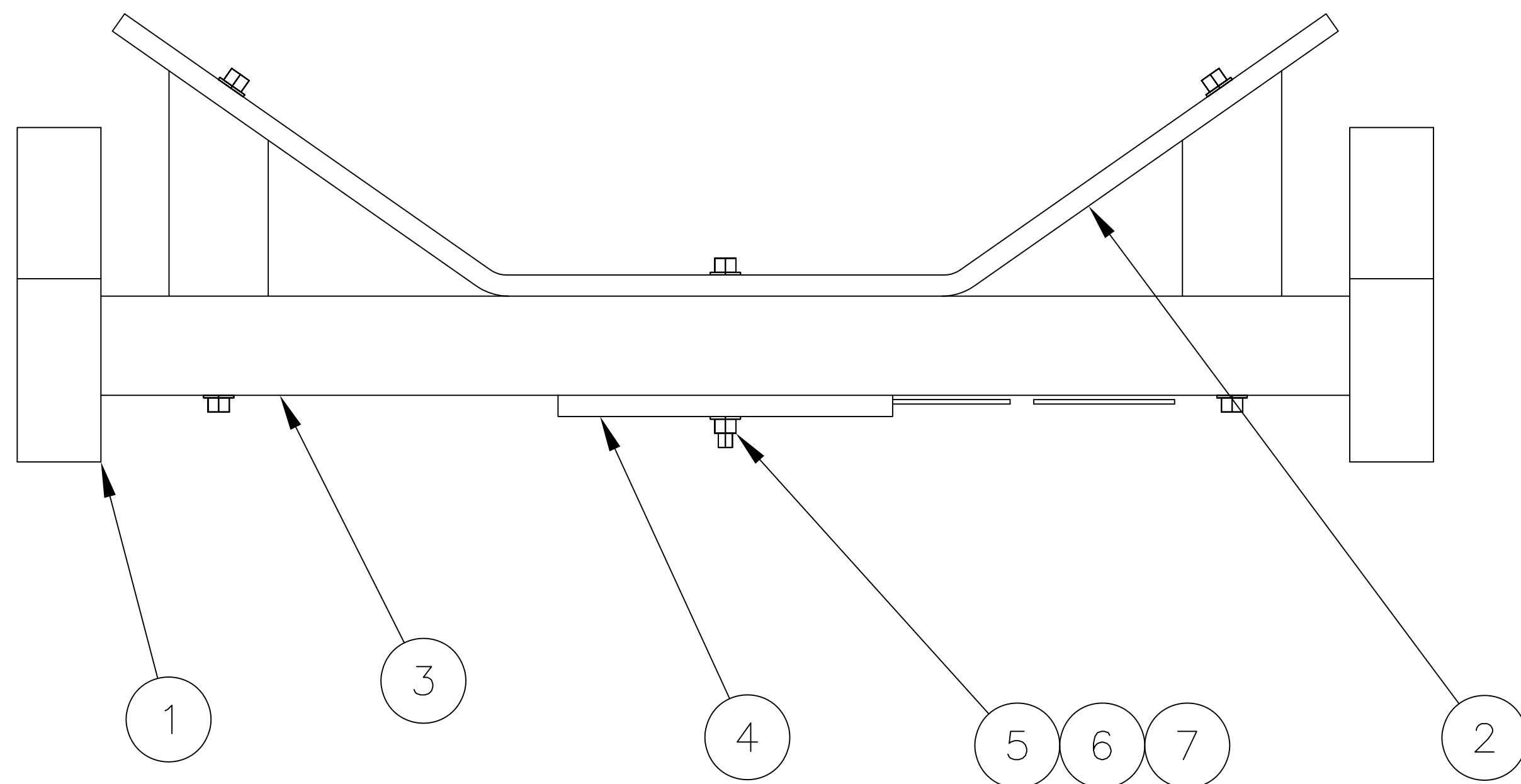
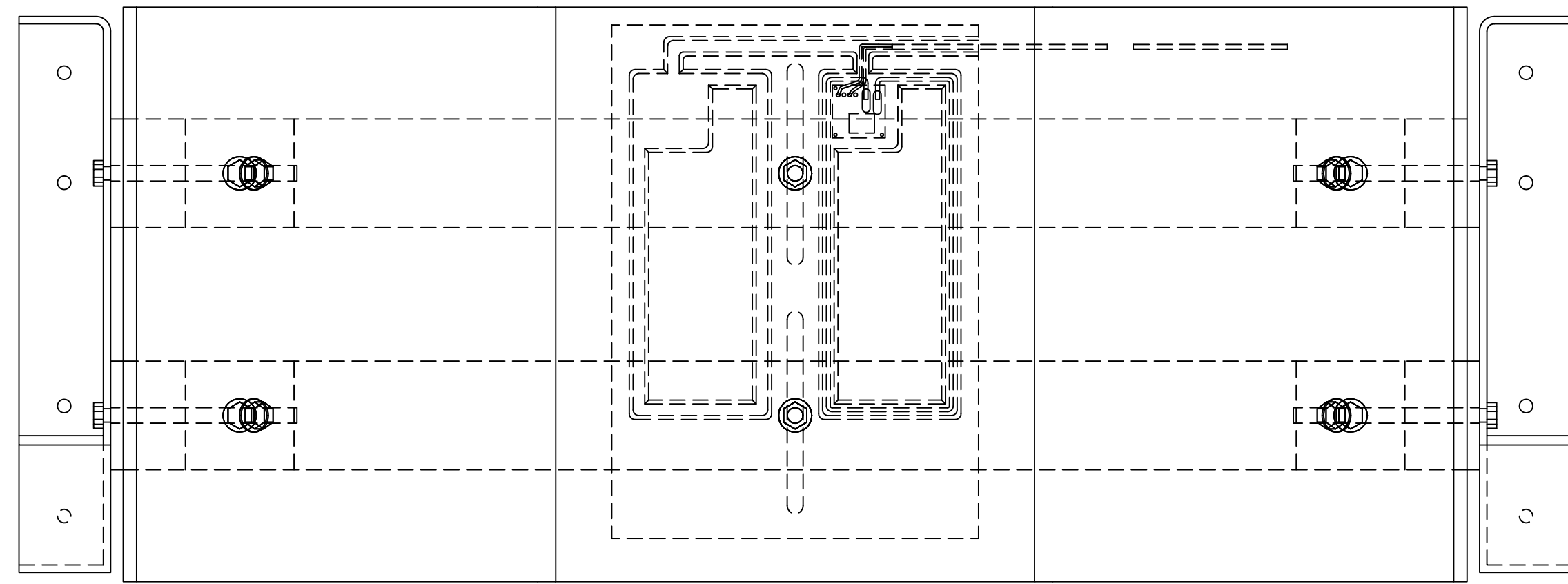

← BELT TRAVEL

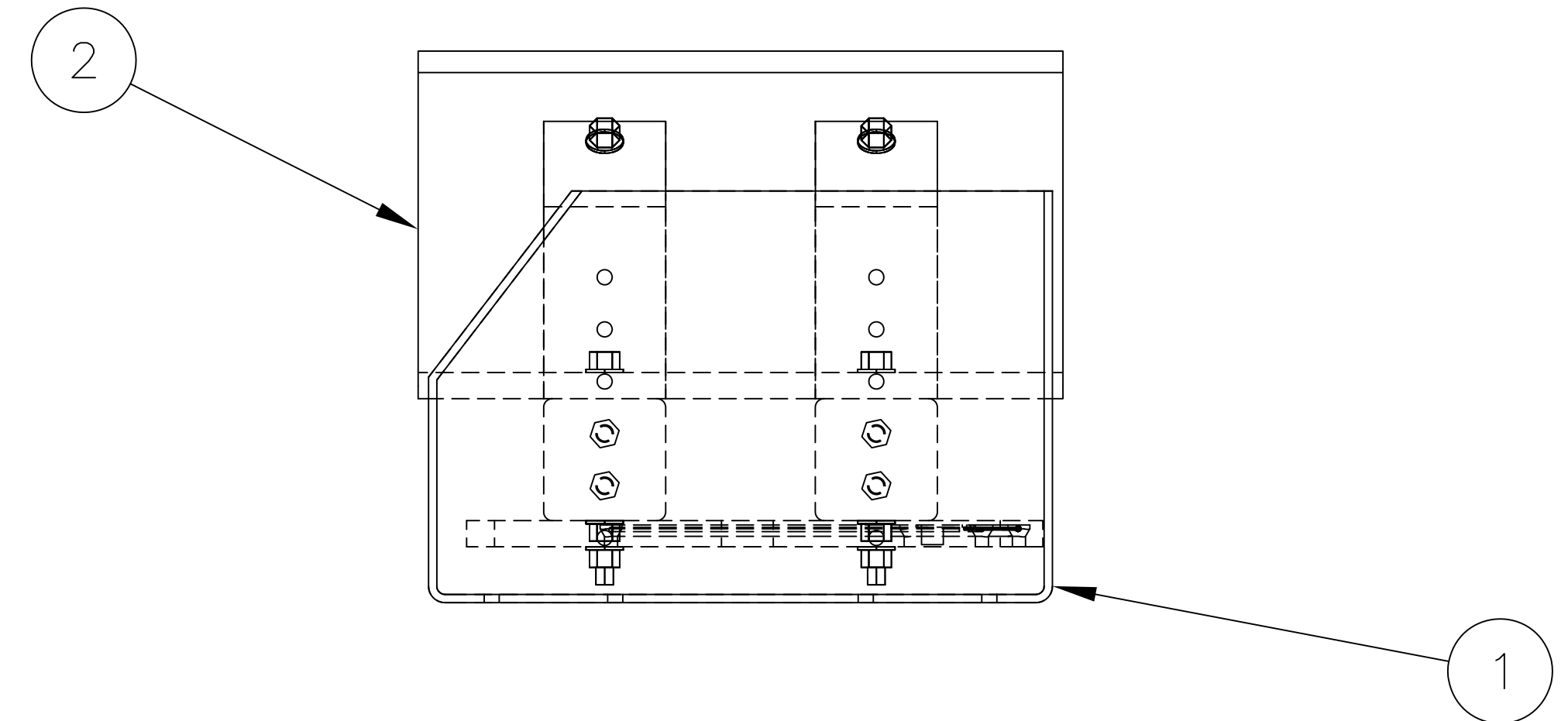

VERSION	ITEM 4	
	DRAWING NO.	PART NO.
STANDARD EST	D07328C-K001	068379
HIGH STRENGTH EST	D07328C-K002	068379

NOTES:

1. REMOVE TWO CENTER BOLTS FROM PLATE BY FIRST REMOVING NUT (LOCATED UNDER SUPPORT BEAM). DISCARD BOLTS.
2. POSITION THE EST (ITEM 4) UNIT FACING POTTING SIDE DOWNWARD UNDER SUPPORT BEAM, WITH THE CABLE END TOWARD THE SAME SIDE AS THE CABLE ON THE METAL DETECTOR (ITEM 2).
3. INSERT TWO BOLTS (ITEM 5) PROVIDED WITH EST UNIT, APPLY WASHERS (ITEM 6) AND NUTS (ITEM 7) AND TIGHTEN.

REV	ECO NO	MICRO	DESCRIPTION	DATE	BY	APPD
C	2180		CORRECT LOGO	4-21-10	RAE	RAE
B	0854		FORMAT CHANGE	5-3-01	LB	RWT
A	2673		RELEASE	5-3-01	LB	JLB

CADD DATABASE: AUTOCAD METRIC A1

DO NOT SCALE DWG	SCALE NONE	<small>This document is confidential and is the property of Thermo Fisher Scientific. It may not be copied or reproduced in any way without the expressed written consent of Thermo Fisher Scientific. This document also is an unpublished work of Thermo Fisher Scientific. Thermo Fisher Scientific intends to and is maintaining the work as confidential information. Thermo Fisher Scientific also may seek to protect this work as an unpublished copyright. In the event of other treatment or subsequent publication, Thermo Fisher Scientific intends to enforce its right to this work under the copyright law as a published work. Those having access to this work may not copy, use or disclose the information in this work unless expressly authorized by Thermo Fisher Scientific.</small>
REMOVE ALL BURRS AND UNNECESSARY SHARP EDGES	JOB NO	
TOLERANCE UNLESS SPECIFIED	ENG JLB	DATE 5-2-01
.X ± 1.5 mm .06 in.	DWN	DATE 5-2-01
.XX ± 0.8 mm .03 in.	JLB	DATE 5-2-01
.XXX ± 0.3 mm .01 in.	CHK	DATE 5-2-01
FRACT. ± 1/16	JLB	DATE 5-2-01
ANGLES ± .50° 1/2°		
NEXT ASS'Y		
CUST ORDER NO		
CUSTOMER LOCATION		
USER LOCATION		

ThermoFisher SCIENTIFIC

UNDER BELT SINGLE COIL OUTLINE AND MOUNTING EST TRAMP METAL DETECTOR

PART NO	DRAWING NUMBER	REV
	D07328C-B102	C

© 01, by Thermo Fisher Scientific