

OPERATING AND SERVICE MANUAL

FOR RAMSEY

MICRO-TECH™ 2000

MODEL 2101

INTEGRATOR

RAMSEY
A THERMO SENTRON COMPANY

501 90th Avenue N.W. • Minneapolis, MN 55433 • 763.783.2500

REC 3896 REV F
PART NO. 049064

REVISION HISTORY

REVISION	DATE	SOFTWARE VERSION
A	JUNE 1995	
B	FEBRUARY 1996	
C	FEBRUARY 1997	
D	APRIL 1998	
E	NOVEMBER 1998	
F	APRIL 2000	33.00.03.05

COPYRIGHT 1995, 1996, 1997, 1998, 2000 BY RAMSEY TECHNOLOGY, INC.

THIS DOCUMENT IS CONFIDENTIAL AND IS THE PROPERTY OF RAMSEY TECHNOLOGY, INC. ("RAMSEY"). IT MAY NOT BE COPIED OR REPRODUCED IN ANY WAY WITHOUT THE EXPRESS WRITTEN CONSENT OF RAMSEY. THIS DOCUMENT ALSO IS AN UNPUBLISHED WORK OF RAMSEY. RAMSEY INTENDS TO AND IS MAINTAINING THE WORK AS CONFIDENTIAL INFORMATION. RAMSEY ALSO MAY SEEK TO PROTECT THIS WORK AS AN UNPUBLISHED COPYRIGHT. IN THE EVENT OF EITHER INADVERTENT OR DELIBERATE PUBLICATION, RAMSEY INTENDS TO ENFORCE ITS RIGHTS TO THIS WORK UNDER THE COPYRIGHT LAWS AS A PUBLISHED WORK. THOSE HAVING ACCESS TO THIS WORK MAY NOT COPY, USE OR DISCLOSE THE INFORMATION IN THIS WORK UNLESS EXPRESSLY AUTHORIZED BY RAMSEY.

**PLEASE READ AND OBSERVE THE FOLLOWING SAFETY
PRECAUTIONS FOUND THROUGHOUT THIS MANUAL.**

DANGER

FAILURE TO OBSERVE WILL CAUSE VERY SERIOUS PERSONAL INJURY OR DEATH.

WARNING

FAILURE TO OBSERVE COULD CAUSE SERIOUS PERSONAL INJURY.

CAUTION

FAILURE TO OBSERVE MAY CAUSE MINOR OR MODERATE PERSONAL INJURY
OR DAMAGE TO THE EQUIPMENT.

RAMSEY PRODUCTS
MICRO-TECH 2000 MODEL 2101 INTEGRATOR

TABLE OF CONTENTS

<u>CHAPTER</u>	<u>TITLE</u>	<u>PAGE</u>
1.0	INTRODUCTION	1-1
1.1	GENERAL	1-1
1.2	APPLICATION	1-1
1.3	MAIN FEATURES	1-1
	1.3.1 Integrator Configuration	1-3
1.4	INTEGRATOR GENERAL DESCRIPTION	1-3
	1.4.1 Measuring Functions	1-3
	1.4.2 Monitoring Functions	1-4
	1.4.3 Print Functions	1-4
	1.4.4 Communications (Optional)	1-4
1.5	FUNCTIONAL DESCRIPTION	1-5
	1.5.1 Measuring Functions	1-5
	1.5.2 Load Out (Optional)	1-6
	1.5.3 Monitoring Functions	1-7
1.6	WARRANTY	1-8
1.7	UNPACKING AND INSPECTION	1-9
1.8	STORAGE	1-9
1.9	SYMBOL IDENTIFICATION	1-9
1.10	HARDWARE SPECIFICATIONS	1-10
	1.10.1 Enclosure	1-10
	1.10.2 Environmental Conditions	1-10
	1.10.3 Power Requirements	1-10
	1.10.4 AC Power Supply	1-11
	1.10.5 DC Power Supplies	1-11
	1.10.6 Load Cell (Weight)	1-11
	1.10.7 Speed Inputs	1-11
	1.10.8 Mother Board Digital Inputs	1-13
	1.10.9 Mother Board Digital Outputs and Fault Output	1-14
	1.10.10 Analog I/O Board B (Optional)	1-15

TABLE OF CONTENTS
(continued)

<u>CHAPTER</u>	<u>TITLE</u>	<u>PAGE</u>
	1.10.11 Analog I/O Board A	1-16
	1.10.12 Communication Board A	1-16
	1.10.13 Allen-Bradley Remote I/O	1-17
	1.10.14 PROFIBUS-DP	1-17
2.0	INSTALLATION	2-1
2.1	GENERAL	2-1
2.2	FIELD MOUNT INSTALLATION	2-1
	2.2.1 Mounting	2-1
	2.2.2 Safety Precautions	2-3
	2.2.3 OSHA - Occupational Safety and Health Act	2-4
	2.2.4 Utility Connections (Incoming Power)	2-4
	2.2.5 Wiring	2-4
2.3	PANEL MOUNT INSTALLATION	2-8
	2.3.1 Mounting	2-8
	2.3.2 Safety Precautions	2-10
	2.3.3 OSHA - Occupational Safety and Health Act	2-11
	2.3.4 Utility Connections (Incoming Power)	2-11
	2.3.5 Wiring	2-13
2.4	INTEGRATOR CONFIGURATION	2-14
	2.4.1 Mother Board Configuration Jumpers and Switches	2-14
	2.4.2 Field Terminal Board (Field Mount Only)	2-16
	2.4.3 A/D Board Jumpers	2-16
	2.4.4 Analog Input/Output Board	2-19
	2.4.5 Communications Board Configuration	2-19
	2.4.6 Load Out Option	2-19
2.5	INITIAL SETUP PROCEDURE	2-21
	2.5.1 Determining Installation Parameters	2-21
	2.5.2 Programming the Micro-Tech 2101 Integrator	2-29

TABLE OF CONTENTS
(continued)

<u>CHAPTER</u>	<u>TITLE</u>	<u>PAGE</u>
3.0	OPERATION	3-1
3.1	GENERAL	3-1
3.2	OVERVIEW	3-1
3.3	FRONT PANEL	3-1
	3.3.1 LED Status Indicators	3-2
	3.3.2 Keyboard	3-2
	3.3.3 Display	3-2
3.4	MENU DISPLAYS	3-3
3.5	NORMAL POWER ON	3-4
	3.5.1 Hardware Configuration	3-4
3.6	RUN MENU	3-5
	3.6.1 Main Run	3-5
	3.6.2 Reset Total	3-5
	3.6.3 Material Calibration	3-6
	3.6.4 Alarm Pending	3-6
3.7	TOTAL KEY	3-7
3.8	START-STOP KEYS	3-8
3.9	CALIBRATION	3-8
	3.9.1 Zero Calibrate Scroll	3-8
	3.9.2 Span Calibration Scroll	3-10
	3.9.3 Material Span Calibration	3-15
3.10	PERMANENT SCROLL RECORD - SETUP SCROLLS	3-19
3.11	PERMANENT FIELD RECORD	3-29
3.12	CALIBRATION REPORT	3-30
4.0	MAINTENANCE	4-1
4.1	SERVICE AND REPAIR	4-1
4.2	FREQUENT CHECKPOINTS	4-1
4.3	TROUBLESHOOTING	4-1
	4.3.1 Alarm Message	4-1
	4.3.2 Alarms List	4-2

TABLE OF CONTENTS
(continued)

<u>CHAPTER</u>	<u>TITLE</u>	<u>PAGE</u>
	4.3.3 Micro-Tech 2000 Cold Start	4-5
	4.3.4 Internal Test Procedure	4-6
	4.3.5 Load Cell Excitation and Signal Voltage	4-7
	4.3.6 Resetting Master Total Procedure	4-7
	4.3.7 To Remove a Forgotten Password	4-8
4.4	LITHIUM BATTERY REPLACEMENT	4-8
4.5	DISPOSAL OF HAZARDOUS WASTE	4-9
4.6	CLEANING INSTRUCTIONS	4-9
5.0	REPLACEMENT PARTS	5-1
5.1	GENERAL	5-1
5.2	ORDER INFORMATION	5-1
	5.2.1 Return Material Authorization	5-2
	5.2.2 Parts List	5-3

LIST OF ILLUSTRATIONS

<u>FIGURE NO.</u>	<u>TITLE</u>	<u>PAGE</u>
1-1	Micro-Tech 2000, Model 2101 Field Mount Integrator	1-2
1-2	Micro-Tech 2000, Model 2101 Panel Mount Integrator	1-2
1-3	Speed Sensor Input	1-12
1-4	AC Input Module	1-13
1-5	DC Input Module	1-13
1-6	AC Output Module	1-14
1-7	DC Output Module	1-14
1-8	High-Level Analog Input	1-15
1-9	High-Level Analog Output	1-16
2-1	Typical Micro-Tech 2101 Installation	2-1
2-2	Electrical & Mounting Guidelines Micro-Tech 2000, Model 2101 (Field Mount) Integrator	2-2
2-3	Field Terminal Board	2-6
2-4	Field Wiring Diagram, Field Mount with Terminal Board	2-7
2-5	Electrical & Mounting Guidelines Micro-Tech 2000, Model 2101 (Panel Mount) Integrator	2-8
2-6	Installation Micro-Tech 2000, Model 2101 (Panel Mount) Integrator	2-9
2-7	Field Wiring Diagram, Field Mount without Field Terminal Board or Panel Mount	2-12
2-8	Model 2101 Mother Board	2-15
2-9	Load Cell A/D Board	2-17
2-10	Field Terminal Board	2-18
2-11	Analog I/O Board	2-20
2-12	Belt Scale Weighbridge	2-22
2-13	Pivot to Load Cell	2-23
2-14	Pivot to 1st Idler	2-23
2-15	Pivot to 2nd Weigh Idler	2-24
2-16	Pivot to 1st, 2nd, 3rd and 4th Idler	2-24
2-17	Pivot to Test Weight Height	2-25
2-18	Pivot to Test Weight Length	2-25
2-19	Pivot to Weighbridge Height	2-26
2-20	Roll to Weighbridge Height	2-26
2-21	Measuring Angle of Incline	2-28
2-22	Micro-Tech 2101 CPU Board	2-29
3-1	Model 2101 Integrator Front Panel	3-1
4-1	Model 2101 Mother Board	4-9

LIST OF TABLES

<u>TABLE NO.</u>	<u>TITLE</u>	<u>PAGE</u>
1-1	Symbol Identification	1-9

APPENDIX

<u>NO.</u>	<u>TITLE</u>	
A/1	Ramsey Weighbridge Physical Parameters	
A/2	Linearization (Request REC 3909 from factory)	
A/3	Digital Input/Output Module	
A/4	MT2101 Menus	
* A/5	Load Out	REC 3910
A/6	MT2101 Multi-Point Calibration	
A/7	Menu Tree Drawings (Sheets 1 through 4)	C07257B-V100

* If option is supplied.

CHAPTER 1.0 INTRODUCTION

1.1 GENERAL

This instruction manual contains information on the installation, operation, calibration, and maintenance of the Micro-Tech 2000 Model 2101 Field Mount and Panel Mount conveyor belt scale Integrator.

1.2 APPLICATION

The Micro-Tech 2101 Field Mount Integrator (Figure 1-1) or Panel Mount Integrator (Figure 1-2) is a micro-computer driven instrument used for deriving rate and quantity of flowing material from signals representing the weight of a segment (pounds/foot) of moving material and its velocity (feet/minute).

By suitable processing of these two input signals, the Integrator delivers visible and electrical output representing the rate of material movement and visible and electrical output representing total amount of material which has passed the weighbridge.

For remote indicating, four options are available:

1. Remote totalization.
2. Remote flow rate, belt loading or belt speed.
3. Communications.
4. Field Bus

The Integrator has provisions for three programmable logical inputs, three programmable logical outputs, and one fault output. In addition to the standard inputs, optional digital input/output boards can be added.

Many automatic and check functions are available to the operator for calibration and maintenance.

1.3 MAIN FEATURES

The Model 2101 integrator (Figure 1-1) or panel mount integrator (Figure 1-2) has many hardware and software features necessary for continuous weighing and outputting totalized weight and rate information. The main features are listed below. Other features are listed in specific sections of this manual.

- Menu driven scroll entries on a four line display
- Five LED status indicators
- Visible and electrical outputs representing rate or load of the material movement
- Visible and electrical output representing total amount of material that has passed the weighbridge
- Audit trail (option)
- Automatic zero and span calibration
- Auto zero tracking
- Several software options that may be turned on by keyboard entry or by installing optional plug-in PC boards
- Optically coupled digital inputs and outputs
- Alarms and failure detection
- Communication standards: RS232C, RS485 networking and multidrop, 20 mA current loop passive
- Allen-Bradley Remote I/O

- PROFIBUS-DP

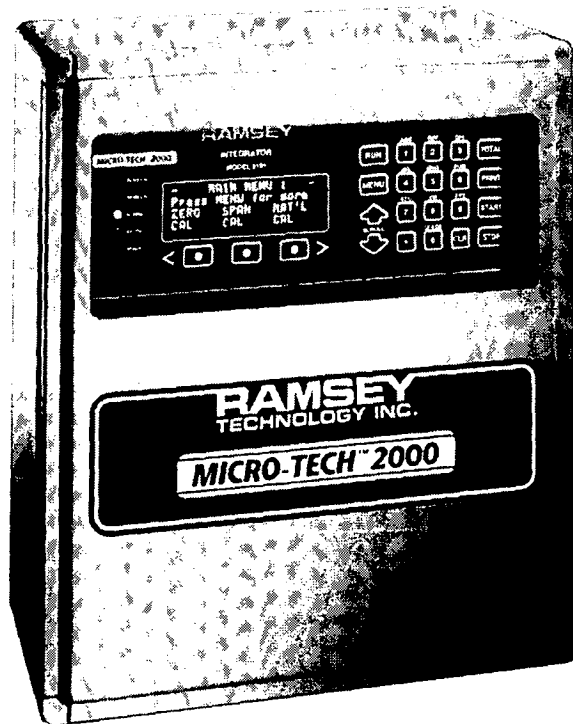

P00063

MICRO-TECH 2000
MODEL 2101 FIELD MOUNT INTEGRATOR
FIGURE 1-1

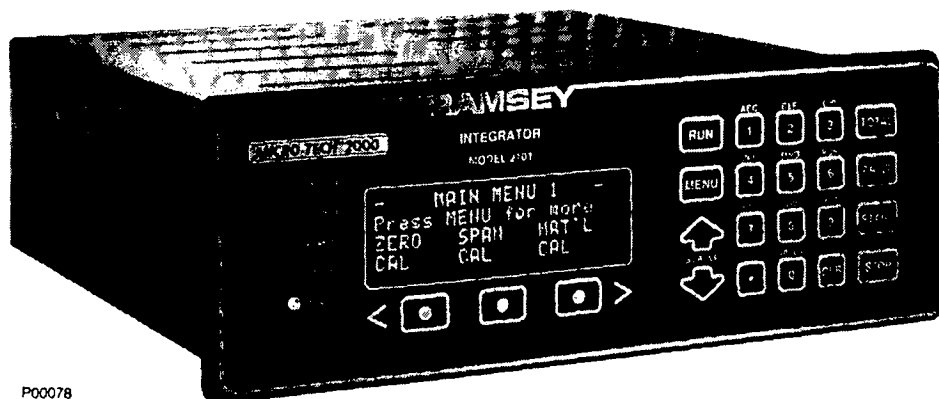

P00078

MICRO-TECH 2000
MODEL 2101 PANEL MOUNT INTEGRATOR
FIGURE 1-2

1.3.1 Integrator Configuration

The standard configuration of the integrator includes one single channel plant scale A/D board, one single channel current output board and one remote total pulse output module.

Four more circuit board expansion slots are available. The following boards can be inserted if the need arises.

- Single channel current output board
- Dual channel current output, analog input board
- 16 digital inputs / 4 digital outputs
- 4 digital inputs / 16 digital outputs
- Serial communication board
- Allen-Bradley remote I/O board
- PROFIBUS-DP board

1.4 INTEGRATOR GENERAL DESCRIPTION

The integrator has been designed for belt scales, and is capable of performing all the necessary measuring functions.

All the required functions are resident in the software of the microprocessor. Optional functions are automatically turned on when the relevant hardware is installed, or after the operator has selected them through the keyboard. In all cases, there is no need for special software to be created.

Although the program of the Micro-Tech 2101 is thus very large, the set up of the instrument is very easy, since it is performed by entering parameters through the keyboard following the guidelines of comprehensive messages appearing on the four line display.

The set up parameters may be divided into the following main groups:

- Measuring
- Monitoring
- Printing
- Communication

1.4.1 Measuring Functions

The integrator can be directly connected to up to six 350 ohm load cells and receives the signal of a speed sensor in order to calculate belt speed, belt loading and feed rate.

Rate is integrated in time to calculate the amount of material conveyed by the belt (total), and is displayed in three individual registers: total, reset total, operator total.

The integrator can perform automatic zero and span calibrations. When the belt is running and the rate is below a certain percentage, the integrator can perform auto zero tracking, to minimize the error of zero due to material and dust buildup.

Analog (current) output signals can be generated to transmit rate, speed or belt loading to other control devices.

Displayed variables and analog outputs can be smoothed via damping filters, individually programmable.

1.4.2 Monitoring Functions

The integrator includes internal diagnostic that will generate alarms in case of hardware failures or programming errors. The following process alarms are also provided:

- Belt slip
- Alarms for high and low flow rate, speed and weight

Alarms are visible on the display and can be acknowledged and reset through keyboard, digital input or serial line. Alarms can be delayed to avoid intervention in case of short time peaks. Each individual alarm can be programmed to operate as alarm, shut down or to be ignored. Two LEDs indicate the cumulative status of alarms and shut-down. Digital outputs are also provided for the following:

- Hardware failure
- Alarm cumulative
- Shut down cumulative

1.4.3 Print Functions

Periodical and under command prints can be obtained by connecting a serial printer to an optional communication board. Time and date are permanently stored in battery backed memory. The entire set up of the instrument can also be printed out.

1.4.4 Communications (Optional)

1. Serial Communications

The communication protocol allows a remote intelligent device to read and eventually write the contents of the registers.

During the communication activity, the Micro-Tech 2101 always acts as a Slave, meaning it responds to a request from a Master device on the line, but never attempts to send messages out.

One electrical interface may be selected accessed through one communication port. Up to three communication boards may be installed.

2. Field Bus I/O

Allen-Bradley Remote or PROFIBUS-DP I/O communication link board is typically used to transfer I/O images between a main PLC and remote devices (normally remote I/O racks - rack adapters) or to transfer (read and write blocks of data with intelligent remote devices (node adapters). The Micro-Tech 2101 in this case.

The Remote I/O is a typical master/slave communication where the main PLC is the master or scanner and the remote devices are slaves or adapters.

1.5 FUNCTIONAL DESCRIPTION

1.5.1 Measuring Functions

1. Instantaneous Flow Rate Calculation

The signal delivered by the load cell(s), which represents the weight per unit length of the belt (lbs/ft), is multiplied by the signal delivered by the speed transmitter which represents the belt speed (ft/min). The result of this operation is the instantaneous flow rate (lbs/ft x ft/min = lbs/min) which is then multiplied by suitable constant to obtain the value in the required engineering units (kg/h, ton/h, etc.). An adjustable damping filter is provided separately for displayed rate and current outputs.

2. Flow Totalization

The total is accumulated by multiplying mass per unit length by incremental length and totalizing the result in engineering units.

Three totalizing memories are provided:

- The first memory (Master total) is not resettable to guarantee that the data is not lost because of an unwanted reset.
- The second and third memories (Reset and Operator total) are resettable by the operator and normally used for shift or daily totalization.

3. Zero and Span Automatic Calibrations

Zero and span calibrations are based on belt length defined by a number of belt revolutions.

To calculate the exact number of revolutions, the instrument counts the pulses delivered by the speed transmitter (one pulse represents a specific belt length); when the required number of pulses is reached, the instrument ends the calibration test, and compares the actual totalized value to the theoretical one (0 for zero calibration), and calculates the calibration constant.

The calibration constant is a calculated value that can be factored based on an actual material test.

- Electronic Calibration (R-Cal)

Allows the operator to perform the calibration without the need of applying test weights or test chain on the weighbridge. The electronic calibration checks all the circuitry including the load cell, and is performed by unbalancing the load cell bridge using a precision resistor. The calibration constant is calculated on the basis of the load cell and the scale data.

- Test Weight Calibration

Requires the positioning of test weights on the weighbridge.

- Chain Calibration

Requires the application of calibrated chains on the belt. This method is the nearest to actual operating conditions.

- **Material Test**

Is performed by running a known quantity of material on the scale and weighing that quantity on a static scale of known accuracy.

- 4. **Multiple Calibration Points**

The instrument supports up to 10 different calibrations and linearizations for systems that use a reversing belt or have multiple feed points. The different calibration factors calculated compensate for variations in belt tension and effect on the conveyor belt scale due to the change in loading conditions.

The operator can select which calibration to run by entering the calibration number on the keypad or by selecting it through input contacts. Internally, the instrument has 10 tables each for zero calibration, span calibration, and linearization. When one of them is selected, its values become active.

Refer to Appendix A/6 for information about enabling multiple calibrations and selecting calibration points.

- 5. **Zero Tracking (AZT)**

Under a preset minimum flow rate when enabled, the instrument makes subsequent automatic zero calibrations with the following sequence:

- waits for one-half time of the test duration (a solid "Z" will be displayed);
- execution of a zero test (the "Z" will flash);
- performs automatic zero for one test duration;
- continuously repeats above zero calibration as long as feed rate remains below AZT preset value.

Zero Tracking function is limited to a maximum value of "ZERO LIMIT" that is set in % in the SET UP Scroll.

If the new zero calculated by auto-zero tracking function exceeds that value, an alarm is generated and the new zero is not installed. The reference value for zero is set every time an Auto Zero or Manual Zero is performed.

- 6. **Current Output Signals**

The standard instrument is equipped with one current output signal (0-20/4-20 mA). An optional dual channel current output/analog input board is available. The choice of the signal type is made through the keyboard. Each current output may be programmed via the keyboard to deliver one of the following signals:

- flow rate
- belt loading
- belt speed

Each output has its own adjustable damping and programmable time or length delay.

1.5.2 Load Out (Optional)

The load out option includes additional hardware designed to make the integrator control a batch sequence. Once the system has been set up, the operator enters

the load size and gives the start command. All functions are then controlled by the integrator.

Start and Stop keys on the front panel are operable if the load out option is installed.

The pre-feeder is stopped when the totalized value equals the batch set value minus the overflow correction value.

The START/STOP commands are provided by external signals (manual push-button or relay contact from an automatic system). The stop signal is used only in an emergency to abort the cycle before it ends.

Load sizing can be changed remotely via BCD input.

1.5.3 Monitoring Functions

The integrator is equipped with an indication system. Indication can be in the form of:

- status indications
- process alarms
- programming errors
- equipment failures

1.6 WARRANTY

RAMSEY TECHNOLOGY, INC.

WARRANTY

The seller agrees, represents, and warrants that the equipment delivered hereunder shall be free from defects in material and workmanship. Such warranty shall not apply to accessories, parts, or material purchased by the seller unless they are manufactured pursuant to seller's design, but shall apply to the workmanship incorporated in the installation of such items in the complete equipment. To the extent purchased parts or accessories are covered by the manufacturer's warranty, seller shall extend such warranty to buyer.

Seller's obligation under said warranty is conditioned upon the return of the defective equipment, transportation charges prepaid, to the seller's factory in Minneapolis, Minnesota, and the submission of reasonable proof to seller prior to return of the equipment that the defect is due to a matter embraced within seller's warranty hereunder. Any such defect in material and workmanship shall be presented to seller as soon as such alleged errors or defects are discovered by purchaser and seller is given opportunity to investigate and correct alleged errors or defects and in all cases, buyer must have notified seller thereof within one (1) year after delivery, or one (1) year after installation if the installation was accomplished by the seller.

Said warranty shall not apply if the equipment shall not have been operated and maintained in accordance with seller's written instructions applicable to such equipment, or if such equipment shall have been repaired or altered or modified without seller's approval; provided, however, that the foregoing limitation of warranty insofar as it relates to repairs, alterations, or modifications, shall not be applicable to routine preventive and corrective maintenance which normally occur in the operation of the equipment.

"EXCEPT FOR THOSE WARRANTIES SPECIFICALLY CONTAINED HEREIN, SELLER DISCLAIMS ANY AND ALL WARRANTIES WITH RESPECT TO THE EQUIPMENT DELIVERED HEREUNDER, INCLUDING THE IMPLIED WARRANTIES OF MERCHANTABILITY AND FITNESS FOR USE. THE SOLE LIABILITY OF SELLER ARISING OUT OF THE WARRANTY CONTAINED HEREIN SHALL BE EXCLUSIVELY LIMITED TO BREACH OF THOSE WARRANTIES. THE SOLE AND EXCLUSIVE REMEDY FOR BREACH OF THE WARRANTIES SET OUT ABOVE SHALL BE LIMITED TO THE REPAIR OR REPLACEMENT OF ANY DEFECTIVE ACCESSORY, PART OR MATERIAL WITH A SIMILAR ITEM FREE FROM DEFECT, AND THE CORRECTION OF ANY DEFECT IN WORKMANSHIP. IN NO EVENT SHALL SELLER BE LIABLE FOR ANY INCIDENTAL OR CONSEQUENTIAL DAMAGES."

FIELD SERVICE

Purchaser agrees to underwrite the cost of any labor required for replacement; including time, travel, and living expenses of Ramsey Field Service Engineer at closest factory base.

RAMSEY TECHNOLOGY, INC.
501 90th Avenue N.W.
Minneapolis, MN 55433
Phone: (763) 783-2500
Fax: (763) 783-2525

1.7 UNPACKING AND INSPECTION

The Micro-Tech 2101 Integrator has been properly packaged for shipment and storage, when necessary. Refer to the appropriate manual in the Appendix for unpacking procedures for optional equipment.

Inspect all packages for damage before opening as oftentimes the carrier may be responsible for shipping damage. Refer to the appropriate manual in the Appendix for inspection procedures for optional equipment.





1.8 STORAGE

The Micro-Tech 2101 Integrator can be safely stored, with cover latches secured and hole plugs installed, between -40° to $+158^{\circ}$ F (-40° to $+70^{\circ}$ C). The units should be protected against moisture.

1.9 SYMBOL IDENTIFICATION

Table 1-1 below describes the symbols used in this manual.

**TABLE 1-1
SYMBOL IDENTIFICATION**

Symbol	Description
	Alternating current
	Earth (ground) TERMINAL
	PROTECTIVE CONDUCTOR TERMINAL
	Caution, risk of electric shock
	Caution (refer to accompanying documents)

1.10 HARDWARE SPECIFICATIONS

1.10.1 Enclosure

1. Field
 - NEMA 4X, dust and watertight
 - size 15 x 13 x 7 inches
 - fiberglass reinforced polyester molded blue
 - door window UVA acrylic UL#E64358
 - Stainless steel "Quick" type latch
 - 2 position mounting feet
 - Steel chassis providing EMI/RFI shielding
 - Provision for 7 solid-state input/output modules (4 output, 3 input)
 - power on/off switch (field terminal board option)
2. Panel mount
 - size: DIN43700 96 X 288 mm
 - enlarged bezel for field mount and U.S. panel mount to allow "dust seal"
 - Material: chromated mild steel

1.10.2 Environmental Conditions

1. Mounting
 - Indoor/Outdoor: Should be mounted as close to the load cells as possible without being exposed to excessive heat or moisture.
 - Temperature (Ambient)
 - Storage: -40° to +158° F (-40° to +70° C)
 - Operating: +14° to +122° F (-10° to +50° C)
 - Maximum relative humidity up to 95% non-condensing
 - Pollution degree (pollution degree 2)
 - Altitude up to 6,561 ft (2000 m)

1.10.3 Power Requirements

1. Nominal voltage: 110/120/220/240 VAC, selectable
2. Nominal frequency: 50/60 Hz
3. Operating range: Nominal voltage +10%, -15%
 - 93.5 VAC - 121 VAC (110 VAC Nom.)
 - 102.0 VAC - 132 VAC (120 VAC Nom.)
 - 187.0 VAC - 242 VAC (220 VAC Nom.)
 - 204.0 VAC - 264 VAC (240 VAC Nom.)
4. Fusing: 1.0 Amp Slo-Blo 110/120 VAC, Type T
0.50 Amp Slo-Blo 220/240 VAC, Type T
5. Power Consumption: 50 VA max
6. Maximum non-destructive input voltage: 150/300 VAC for 1 minute
7. Power Switch: Field mount with field terminal board only: switches both L1 and L2

8. Transient overvoltage according to installation category (Overvoltage Category II)

1.10.4 AC Power Supply

- EMI/RFI protection
- 110/120/220/240 VAC input selection by means of TWO switches (UL, CSA, VDE approved) mounted internally.
- 50/60 Hz transformer

1.10.5 DC Power Supplies

1. ● Auxiliary Power Supply Output (Alarm Contacts, etc.)
 - Output voltage: +24 VDC +27/-21%
(19.0/30.4)
unregulated).
 - Isolation: Yes 500 volts
 - Output ripple: 1.0 V peak to peak typical.
 - Output current: 600 mA maximum.
 - Short-circuit protection

1.10.6 Load Cell (Weight)

1. ● Load cell input circuits
 - Number: Up to SIX 350 ohm load cells in parallel. Cable distance 200 ft. or less.
 - Sensitivity: 0.5 mV/V to 3.5 mV/V (keyboard selectable).
 - Input impedance: 100 k Ω minimum.
 - Maximum usable signal: 114% of 3 mV/V.
 - Displayed A/D counts for 3 mV/V: 112368
 - Isolation: Non-isolated.
 - Maximum non destructive input voltage: ± 6 V relative to ground.
 - Transient/RFI protection: NO
 - Load cell cable shield: Connected to earth ground.
2. Load Cell Excitation Power Supply
 - 10 VDC $\pm 10\%$, 220 mA
 - Minimum load impedance (operating) 58 ohms
 - Output short circuit, 1.5 A maximum
3. Excitation-sense circuitry
 - 6 Wire System. Cable distance over 200 ft. (not to exceed 3000 ft.).
 - Nominal input voltage: ± 5 VDC (10 volts)
 - Input impedance: 38 k Ω minimum.
 - Jumper selectable: Local or remote sense.

1.10.7 Speed Inputs

1. ● High speed digital (DC) input
 - speed sensor (Figure 1-3)
 - comparator based input with hysteresis
 - optically isolated
 - built in current source for dry contact use
 - powered by +24 V DIO supply or +20 V SPU supply
 - Type: Jumper selectable:
 - Voltage/current or contact closure type sensor.
 - Compatible with all Ramsey speed sensors.
 - Frequency range:
 - Voltage/current type sensor: 0.25 to 2.0 kHz.
 - Contact closure type sensor: 0.25 to 30 Hz.
 - Low threshold: +1.0 VDC min
 - High threshold: +3.2 VDC max
 - Low or high pulse duration:
 - Voltage/current type sensor: 200 us minimum.
 - Contact closure type sensor: 15 ms minimum.
 - Hysteresis: 0.5 VDC minimum.
 - Input impedance: 10 k Ω typical,
500 ohm minimum.
 - Input source current: -2 mA nom. at 0 VDC.
 - Maximum non-destructive input voltage:
 ± 50 V peak, continuous.
 - Cable Length: 1 mile, using 18 AWG shielded cable, Ramsey series "60" speed sensors.

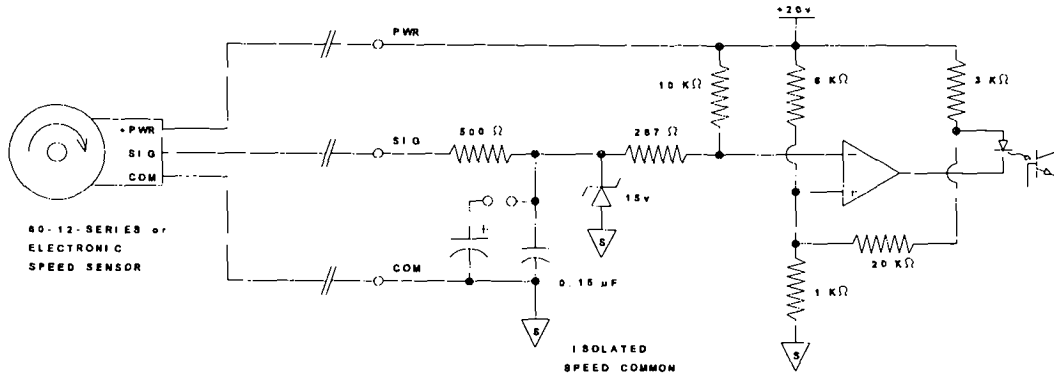

OR:

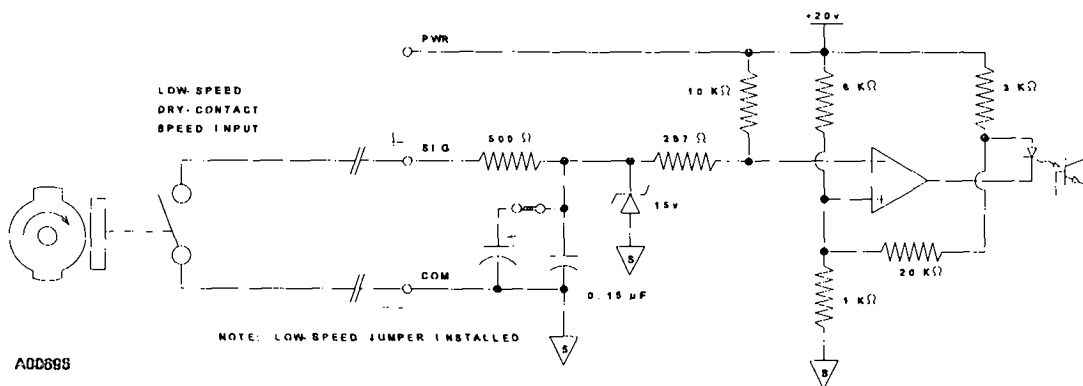

A00685

**SPEED SENSOR INPUT
FIGURE 1-3**

1.10.8 Mother Board Digital Inputs

The field mount integrator has provision on the field terminal board for three OPTO 22/Generation 4 modules. The programmable status inputs may be AC or DC (Figure 1-4 or 1-5).

The panel mount integrator version only accepts a dry contact input. See Appendix A/3 for specifications and a typical wiring diagram.

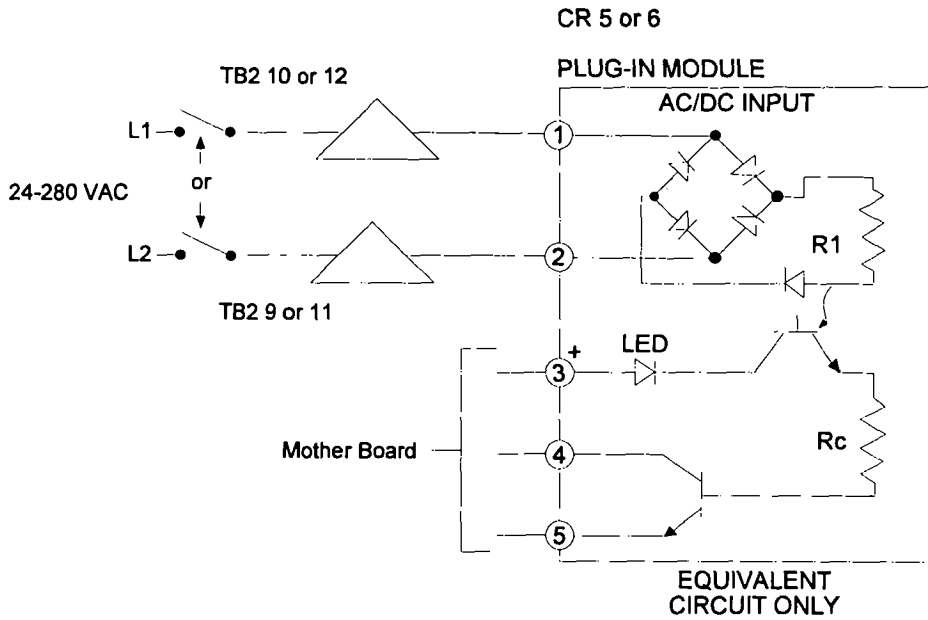

A01719

NEGATIVE TRUE LOGIC

AC INPUT MODULE
FIGURE 1-4

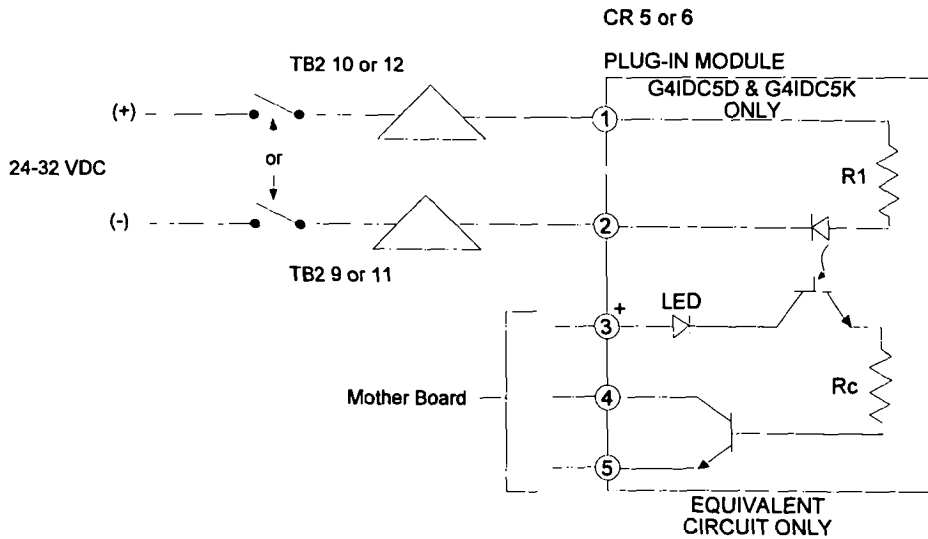

A01720

NEGATIVE TRUE LOGIC

DC INPUT MODULE
FIGURE 1-5

1.10.9 Mother Board Digital Outputs and Fault Output

The field mount integrator has provision on the field terminal board for four OPTO 22/Generation 4 modules. Three are programmable and one is a dedicated fail safe fault output. All outputs may be AC or DC (Figure 1-6 or 1-7).

The panel mount integrator version outputs are 24 VDC, open collector. See Appendix A/3 for specifications and a typical wiring diagram.

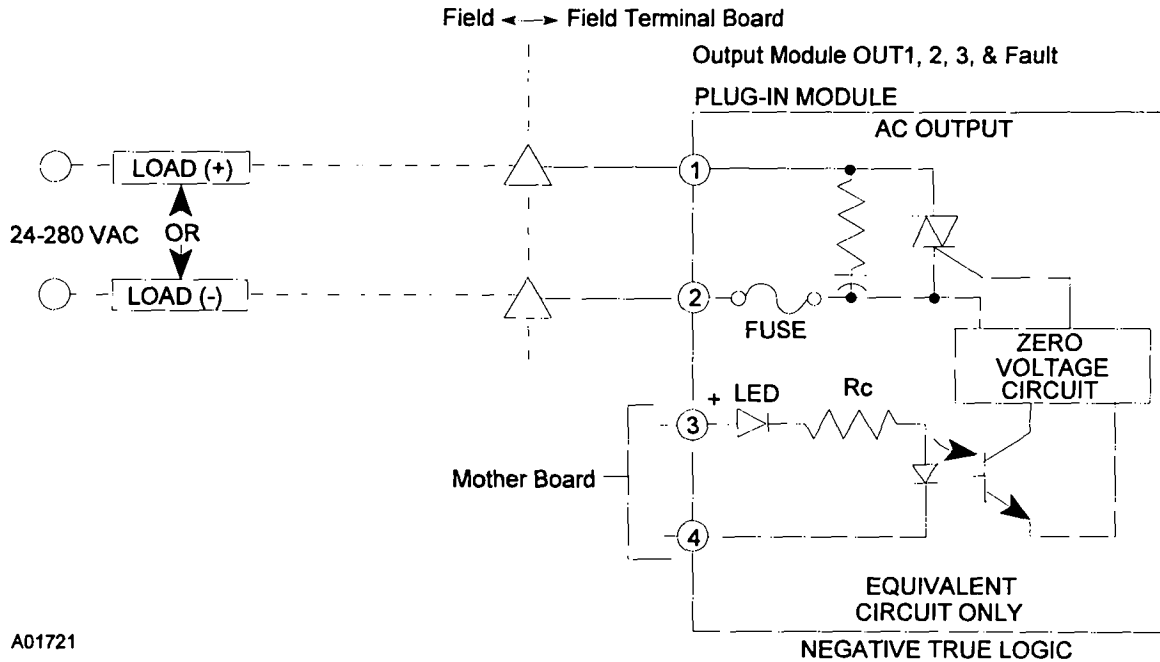

A01721

AC OUTPUT MODULE
FIGURE 1-6

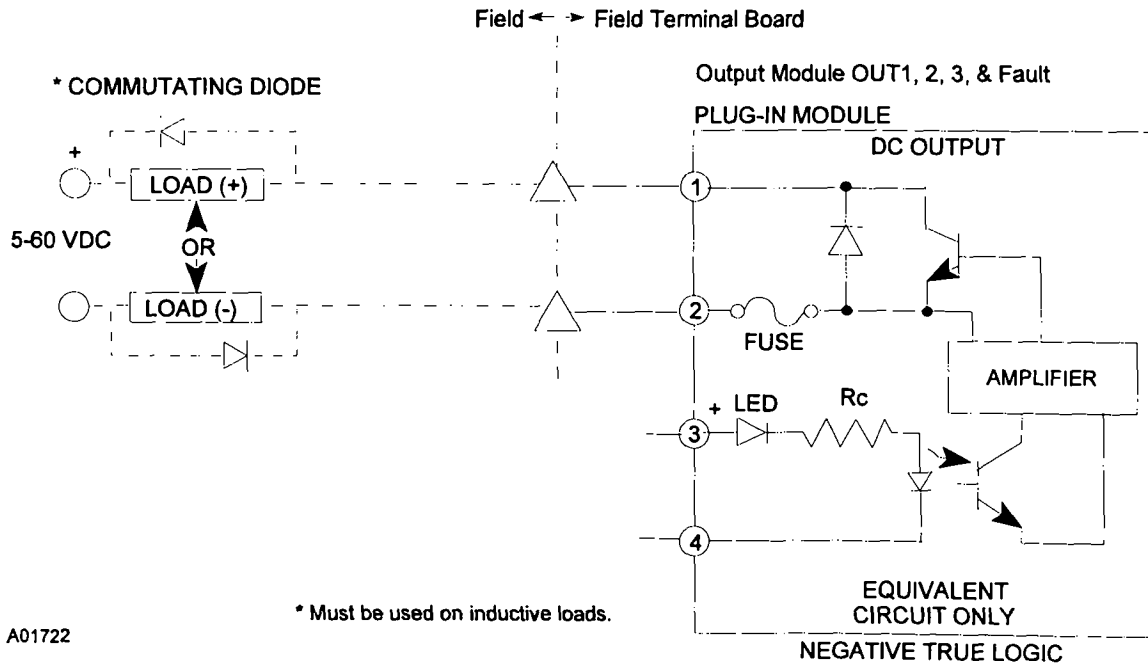

A01722

* Must be used on inductive loads.

DC OUTPUT MODULE
FIGURE 1-7

1.10.10 Analog I/O Board B (Optional)

- (2) high level inputs (Figure 1-8)
 - Type: Differential voltage input.
(0-20 mA or 4-20 mA with internal resistor, jumper selectable)
 - Range: 0-5 volt, or ± 5 volt, programmable.
 - Input impedance: 100 k nominal (differential)
 - Maximum usable input voltage: 106 % of full-scale
 - Non-isolated.
 - Maximum non-destructive input voltage: 12 V peak

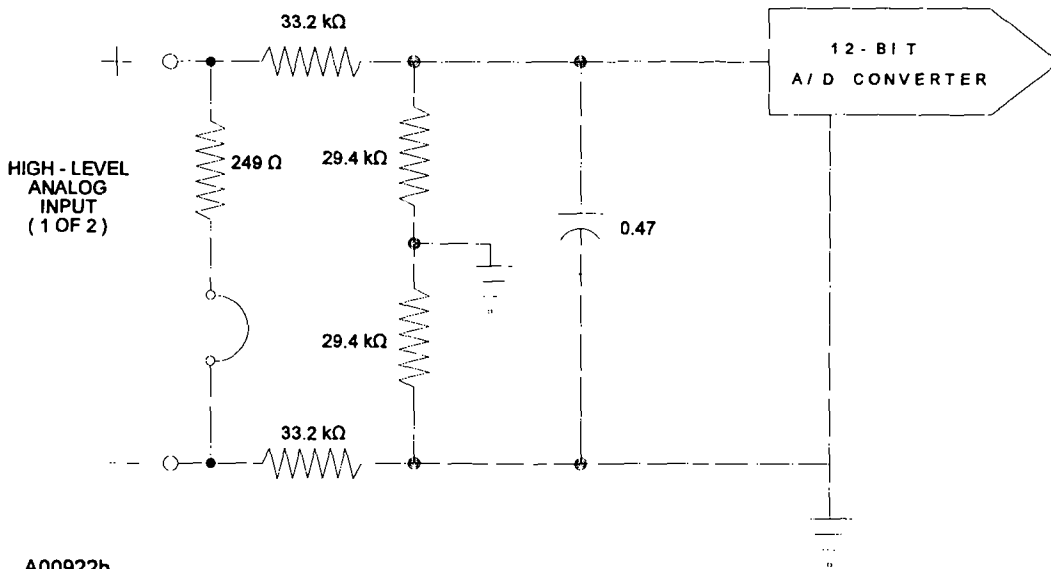

A00922b

HIGH-LEVEL ANALOG INPUT
FIGURE 1-8

2. (2) current outputs (Figure 1-9)

- optically isolated
- isolated power source
- Voltage output by adding an internal dropping resistor.
- Output range: User selectable 0-20 mA or 4-20 mA, representing 0 to 100% variable.
- Resistive load: 800 ohms maximum
- Capacitive load: no limit

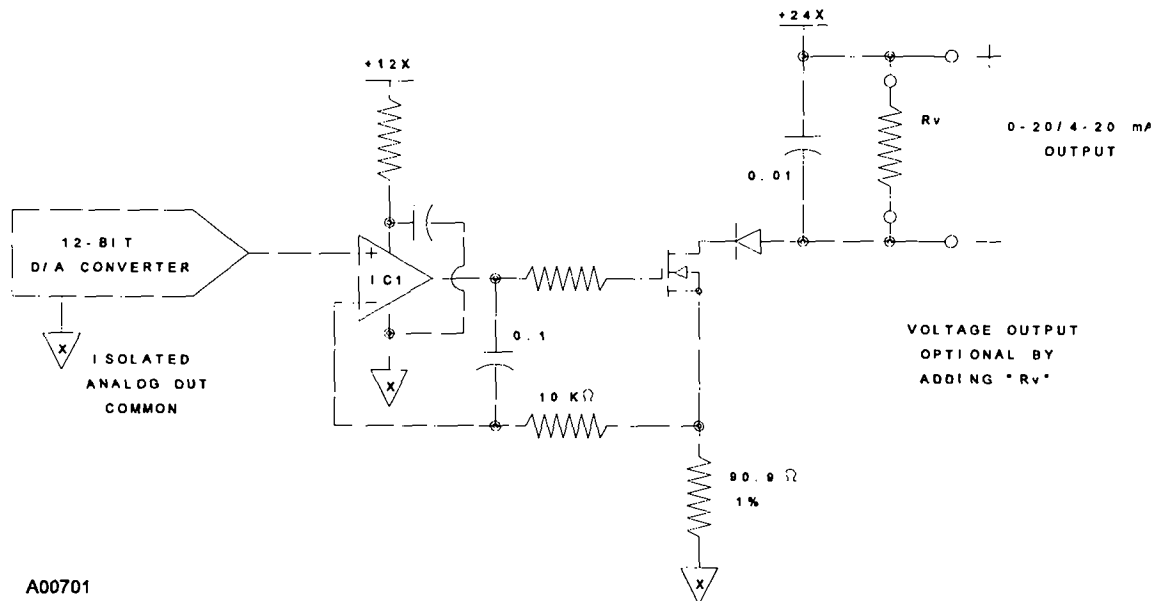

A00701

HIGH-LEVEL ANALOG OUTPUT
FIGURE 1-9

1.10.11 Analog I/O Board A

Depopulated version of Analog I/O B:

1. (1) high level output - see 1.6.9 (2)
 - Resistive load: 800 ohm maximum loop
 - Capacitive load: no limit

1.10.12 Communication Board A

(See Field Wiring Diagram.)

1. Serial Interface
 - Type: Conforms to RS-232C, RS-485/422, and 20 mA standards; supports 2 and 4 wire multi-drop in RS-485. 20 mA loop is passive ONLY.
 - Interfacing: RS-485 supports 2-wire or 4-wire multi-drop networking; RS-232C provides support for modem.
 - Data rate: 300 to 19200, operator selectable from the keyboard.
 - Data format: Asynchronous, bit-serial, selectable parity, data length, and stop bits.
 - Optical isolation, 250 Vrms max.

- Input voltage: ± 30 Vdc max. (RS-232C)
+15/-10 Vdc max. (RS-485)
- Cable length: 50 feet maximum (RS-232C)
4000 feet maximum (RS-485 and 20 mA)

2. Clock Calendar

- Type: Dallas DS1285 with battery backup; provisions of clock/calendar with integrated battery.

3. Refer to Serial Communications manual REC 3949 if this option is installed.

1.10.13 Allen-Bradley Remote I/O

Refer to Allen-Bradley Remote I/O manual REC 4012 if this option is installed.

1.10.14 PROFIBUS-DP

Refer to PROFIBUS-DP manual REC 4063 if this option is installed.

CHAPTER 2.0 INSTALLATION

2.1 GENERAL

This chapter describes the Integrator installation procedure, hardware configuration, and initial programming. Initial programming is a machine directed procedure prompting the operator to enter required conveyor and belt scale parameters. After all parameters have been entered, the integrator performs an unassisted zero and span calibration.

2.2 FIELD MOUNT INSTALLATION

The field mount Integrator should be mounted in a control room environment and not be exposed to excessive vibration, heat or moisture. The Integrator may be mounted up to 3,000 feet from the scale (Figure 2-1).

2.2.1 Mounting

Mount the Integrator to a rigid, flat, vertical surface using four mounting holes provided on the back of the enclosure (Figure 2-2).

Care should be taken to insure the mounting surface is flat so as not to twist or warp the fiberglass enclosure when tightening the mounting bolts.

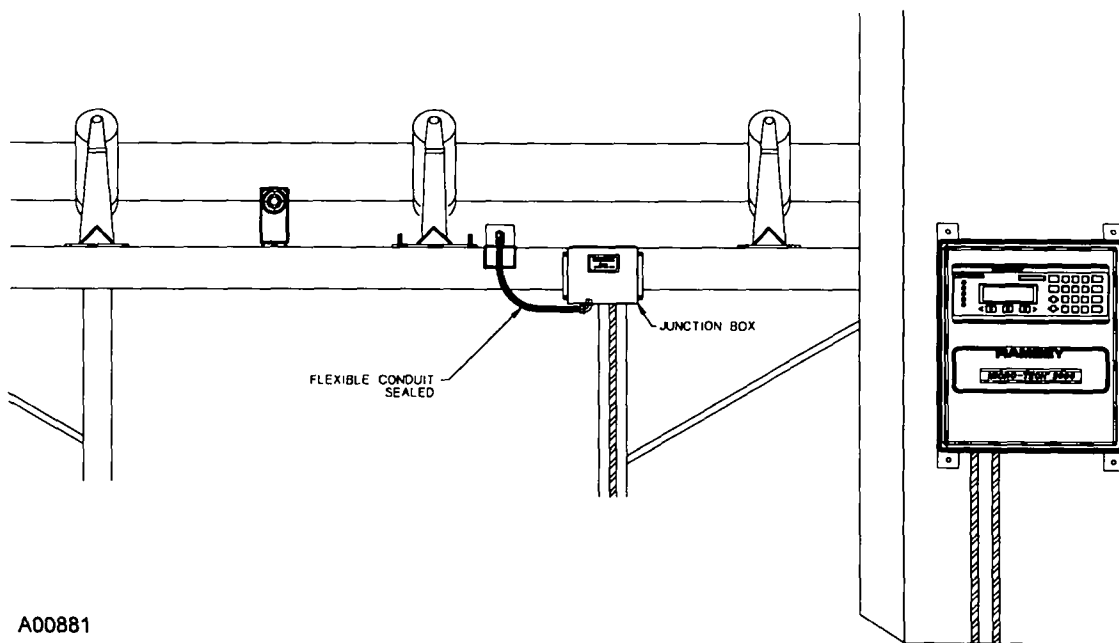

TYPICAL MICRO-TECH 2101 INSTALLATION
FIGURE 2-1

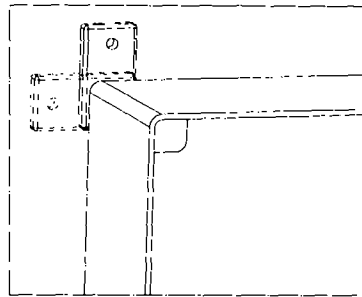

2-POSITION MOUNTING FOOT

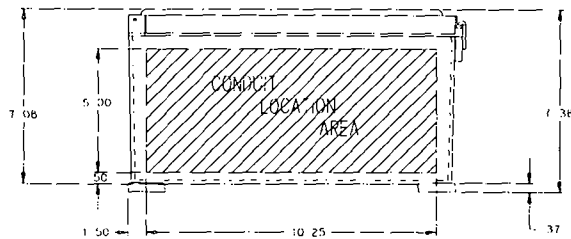
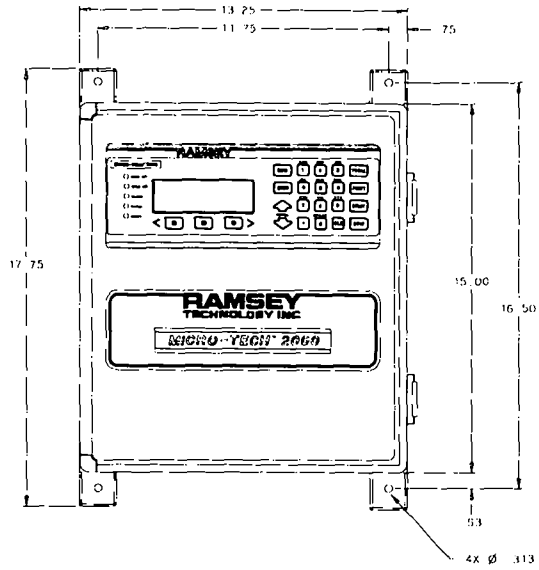

A01732

ELECTRICAL AND MOUNTING GUIDELINES MICRO-TECH 2000
 MODEL 2101 (FIELD MOUNT) INTEGRATOR
 FIGURE 2-2

2.2.2 Safety Precautions



DO NOT INSTALL, OPERATE, OR PERFORM ANY MAINTENANCE PROCEDURES UNTIL YOU HAVE READ THE SAFETY PRECAUTIONS WHICH FOLLOW.

1. Do not connect power to the electronics or turn on the unit until you have read and understood this entire manual. The precautions and procedures presented in this manual must be followed carefully in order to prevent equipment damage and protect the operator from possible injury.
2. **CAUTION**
Hands and clothing must be kept away from all moving or rotating parts.
3. **WARNING**
Covers over the electronics should always remain in place during operation. They should be removed only for maintenance procedures with the machine's power OFF. Be sure to replace all covers before resuming operation.
4. **WARNING**
All switches (such as control or power) must be OFF when checking input AC electrical connections, removing or inserting printed circuit boards, or attaching voltmeters to the system.
5. Incoming voltages must be checked with a voltmeter before being connected to the electronics.
6. **WARNING**
Extreme caution must be used in testing in, on, or around the electronics, PC boards, or modules. There are voltages in excess of 115 V or 230 V in these areas. Avoid high voltage and static electricity around the printed circuit boards.
7. Maintenance procedures should be performed only by qualified service personnel and in accordance with procedures/instructions given in this manual.
8. During maintenance, a safety tag (not supplied by Ramsey) should be displayed in the ON/OFF switch areas as a precaution instructing others not to operate the unit.
9. Only qualified service technicians should be allowed to open and work in the electronics, power supply, control, or switch boxes.
10. Objects should never be placed or stored on the integrator.
11. This equipment should not be operated nor utilized in applications other than those stated in the original order. (To adapt production rates or applications, consult Ramsey Products Customer Service for recommendations.)

12. All panels covering the electronics must be in place and tight before wash down procedures. Damage to the electronics could result from water, moisture, or contamination in the electronics housing.

2.2.3 OSHA - Occupational Safety and Health Act

The Occupational Safety and Health Act clearly places the burden of compliance on the user of the equipment and the act is generalized to the extent that determination of compliance is a judgement decision on the part of the local inspection. Hence, Ramsey Technology, Inc. will not be responsible for meeting the full requirements of OSHA in respect to the equipment supplied or for any penalty assessed for failure to meet the requirements, in respect to the equipment supplied, of the Occupational Safety and Health Act, as interpreted by an authorized inspector. Ramsey Technology, Inc. will use their best efforts to remedy such violation at a reasonable cost to the buyer.

2.2.4 Utility Connections (Incoming Power)



DO NOT CONNECT POWER UNTIL YOU HAVE READ AND UNDERSTOOD THIS ENTIRE SECTION. IMPROPER CONNECTION MAY RESULT IN DAMAGE TO YOUR INTEGRATOR.

CAUTION

VERIFY THAT THE INPUT VOLTAGE IS CORRECT WITH AN AC VOLTMETER BEFORE YOU CONNECT IT TO THE INTEGRATOR.

CAUTION

EARTH GROUND MUST BE PROVIDED TO THE INTEGRATOR. DO NOT USE CONDUIT TO PROVIDE THIS GROUND.

CAUTION

A READILY ACCESSIBLE DISCONNECT DEVICE (MAXIMUM 20 AMP) SHALL BE INCORPORATED IN THE FIELD WIRING. THIS DISCONNECT DEVICE SHOULD BE IN EASY REACH OF THE OPERATOR AND IT MUST BE MARKED AS THE DISCONNECTING DEVICE FOR THE EQUIPMENT.

CAUTION

REFER TO THE FIELD WIRING DIAGRAM (FIGURE 2-3 AND 2-4) AS A GUIDE IF YOU DO NOT HAVE A SPECIFIC WIRING DIAGRAM FOR YOUR SYSTEM. FOLLOW YOUR LOCAL ELECTRONIC CODES AND REGULATIONS FOR MINIMUM WIRE SIZE AND ROUTING.

2.2.5 Wiring

1. Critical wiring conditions:
 - A. Insure power is off.
 - B. Do not route load cell and signal cables in the same conduit with power cables or any large source of electrical noise.

- C. Earth ground all enclosures and conduits. A ground connection between all conduits is required.
 - D. Wiring should be long enough to allow the field terminal entry panel to swing down for circuit board access.
 - E. Connect the shields ONLY where shown.
 - F. Check that all wires are tight in their connections.
 - G. Never use a "megger" to check the wiring.
 - H. A readily accessible disconnect device (maximum 20 amps) shall be incorporated in the field wiring. This disconnect should be in easy reach of the operator and it must be marked as the disconnecting device for the equipment.
 - I. All conduits should enter the bottom of the enclosure. Do not run conduit through the top or sides of the enclosure.
2. To connect incoming power, use the following procedure (see Figure 2-2).

NOTE: All units shipped from the factory are configured for 120 VAC. If another input selection is desired, refer to Section 2.4.1 (Mother Board Configuration Jumpers and Switches).

- A. Rotate the screw latch mounted on the lower left corner of the front chassis counter-clockwise. Open the door.
- B. Route incoming power wiring through a conduit hole at the bottom right of the enclosure (see Figure 2-2). Leave ample loose wiring (typically 8") to facilitate any movement of the field terminal board.
- C. Wire safety ground terminal located on the side of the chassis.
- D. Wire HOT to H on TB7 (see Figure 2-3 and 2-4).
- E. Wire NEUTRAL to N on TB7.
- F. If additional I/O is required at line voltages, these wires should be routed through a conduit hole on the bottom right of the enclosure (see Figure 2-2). Leave ample loose wiring (typically 8") to facilitate any movement of the field terminal board.
- G. All additional field wiring operation at voltages less than 30 V must be located on the left bottom of the enclosure (see Figure 2-2). Leave ample loose wiring (typically 8") to facilitate any movement of the field terminal board.
- H. Close the front chassis cover and rotate the screw lock on the lower left corner counterclockwise until locked. Verify the door is locked.

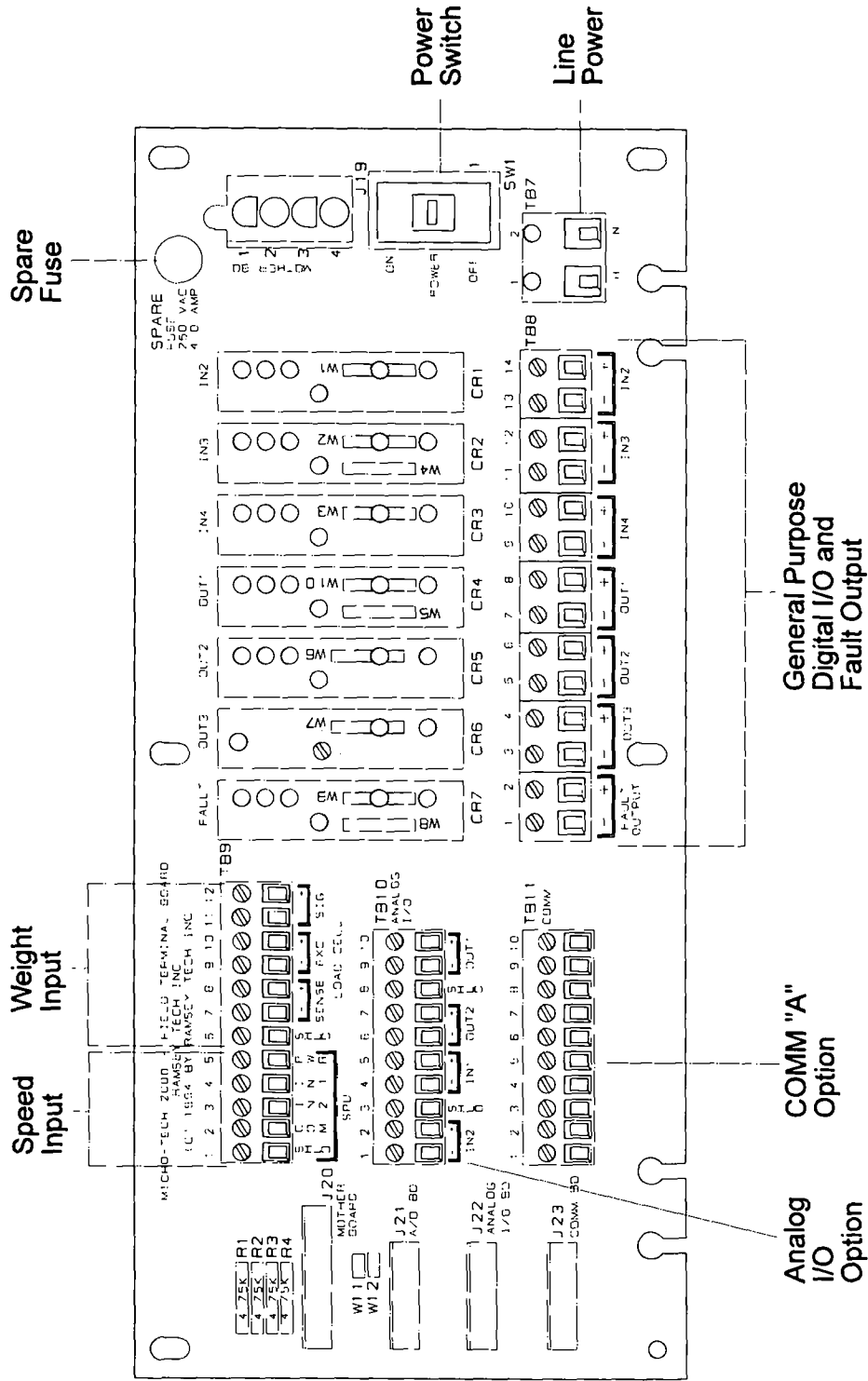

FIELD TERMINAL BOARD
FIGURE 2-3

A00374

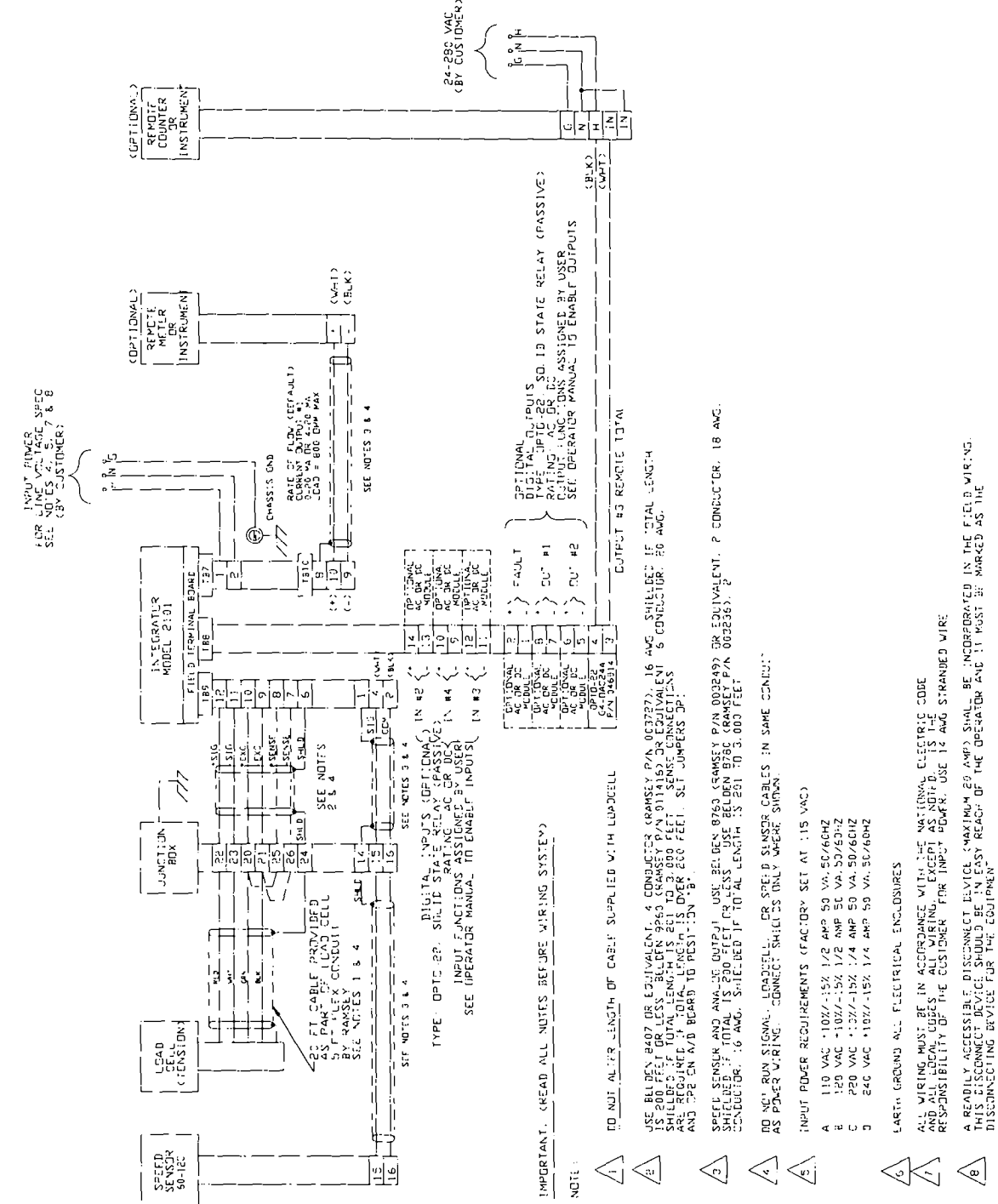

FIELD WIRING DIAGRAM
FIELD MOUNT WITH TERMINAL BOARD
FIGURE 2-4

A00707

2.3 PANEL MOUNT INSTALLATION

The panel mounted Integrator suitable for mounting in a control panel. The control panel should not be exposed to excessive vibration, heat or moisture. The front bezel, when properly seated, forms a dust seal.

A two (2) inch clearance around the top and bottom of the Integrator is required for convection cooling. Additional clearances may be required if equipment mounted directly below generates excessive heat. Clearance in the back is necessary for wiring access and fuse replacement. Clearance on the side is necessary for inserting the chassis holding brackets from the back after insertion of the Integrator.

2.3.1 Mounting

Provide a cutout in the panel and insert the Integrator after removing the holding brackets (see Figures 2-5 and 2-6). From the back, insert the holding brackets on both sides of the Integrator. Tighten the holding brackets to support the Integrator and form the dust seal.

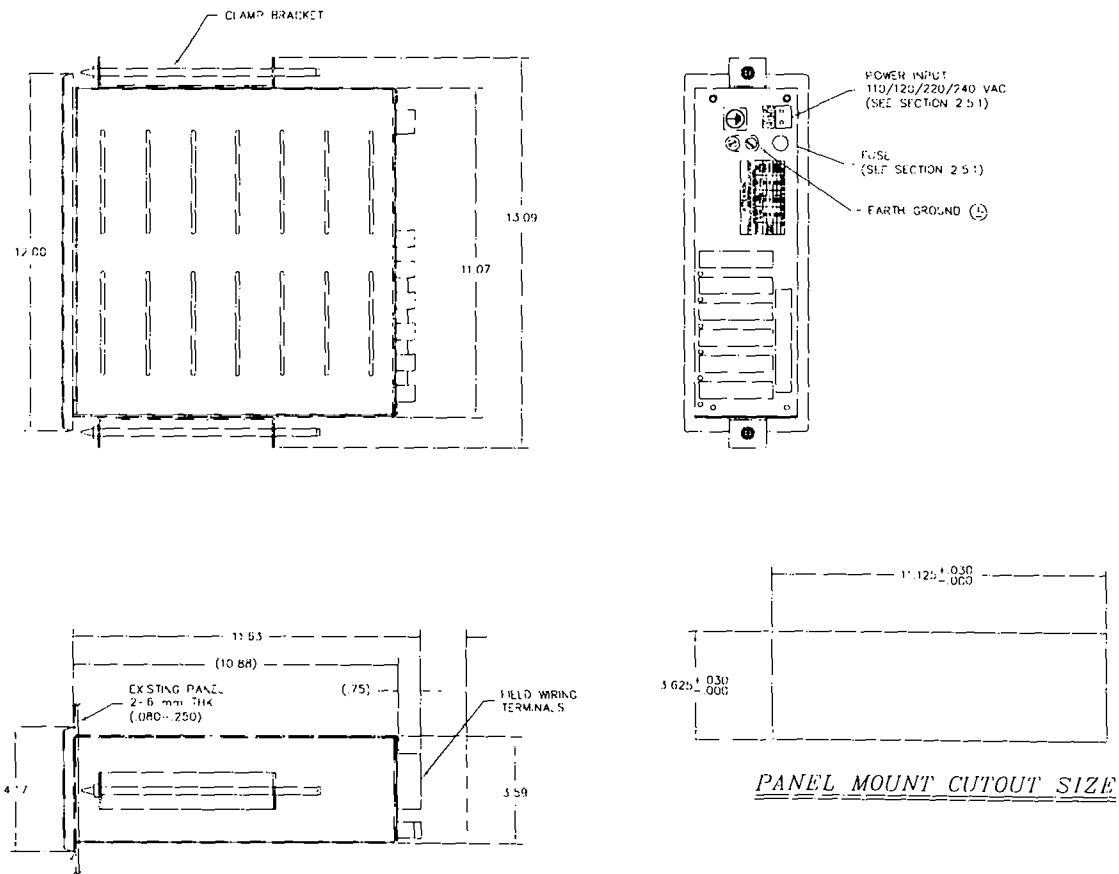

A01716

ELECTRICAL AND MOUNTING GUIDELINES MICRO-TECH 2000
MODEL 2101 (PANEL MOUNT) INTEGRATOR
FIGURE 2-5

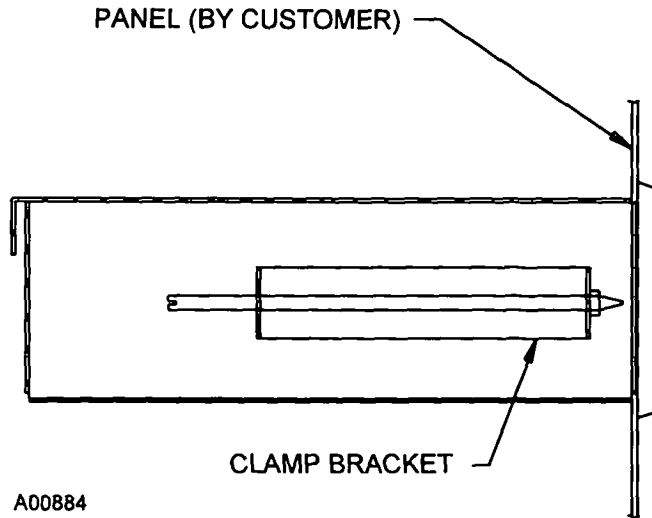

A00884

INSTALLATION MICRO-TECH 2000
MODEL 2101 (PANEL MOUNT) INTEGRATOR
FIGURE 2-6

NOTES:

1. See Figure 2-5 for panel cutout and outline and mounting dimensions.
2. The large rubber band shipped with the unit can be used to hold clamp brackets in place during installation.
3. Remove clamp brackets and slide chassis assembly through front of cut-out. Re-install clamp brackets into chassis and tighten threaded rods against back of panel until unit is secure.

2.3.2 Safety Precautions



DO NOT INSTALL, OPERATE, OR PERFORM ANY MAINTENANCE PROCEDURES UNTIL YOU HAVE READ THE SAFETY PRECAUTIONS WHICH FOLLOW.

1. Do not connect power to the electronics or turn on the unit until you have read and understood this entire manual. The precautions and procedures presented in this manual must be followed carefully in order to prevent equipment damage and protect the operator from possible injury.
2. **CAUTION**
Hands and clothing must be kept away from all moving or rotating parts.
3. **WARNING**
Covers over the electronics should always remain in place during operation. They should be removed only for maintenance procedures with the machine's power OFF. Be sure to replace all covers before resuming operation.
4. **WARNING**
All switches (such as control or power) must be OFF when checking input AC electrical connections, removing or inserting printed circuit boards, or attaching voltmeters to the system.
5. Incoming voltages must be checked with a voltmeter before being connected to the electronics.
6. **WARNING**
Extreme caution must be used in testing in, on, or around the electronics, PC boards, or modules. There are voltages in excess of 115 V or 230 V in these areas. Avoid high voltage and static electricity around the printed circuit boards.
7. Maintenance procedures should be performed only by qualified service personnel and in accordance with procedures/instructions given in this manual.
8. During maintenance, a safety tag (not supplied by Ramsey) should be displayed in the ON/OFF switch areas as a precaution instructing others not to operate the unit.
9. Only qualified service technicians should be allowed to open and work in the electronics, power supply, control, or switch boxes.
10. Objects should never be placed or stored on the integrator.
11. This equipment should not be operated nor utilized in applications other than those stated in the original order. (To adapt production rates or applications, consult Ramsey Products Customer Service for recommendations.)

12. All panels covering the electronics must be in place and tight before wash down procedures. Damage to the electronics could result from water, moisture, or contamination in the electronics housing.

2.3.3 OSHA - Occupational Safety and Health Act

The Occupational Safety and Health Act clearly places the burden of compliance on the user of the equipment and the act is generalized to the extent that determination of compliance is a judgement decision on the part of the local inspection. Hence, Ramsey Technology, Inc. will not be responsible for meeting the full requirements of OSHA in respect to the equipment supplied or for any penalty assessed for failure to meet the requirements, in respect to the equipment supplied, of the Occupational Safety and Health Act, as interpreted by an authorized inspector. Ramsey Technology, Inc. will use their best efforts to remedy such violation at a reasonable cost to the buyer.

2.3.4 Utility Connections (Incoming Power)



CAUTION

DO NOT CONNECT POWER UNTIL YOU HAVE READ AND UNDERSTOOD THIS ENTIRE SECTION. IMPROPER CONNECTION MAY RESULT IN DAMAGE TO YOUR INTEGRATOR.

CAUTION

VERIFY THAT THE INPUT VOLTAGE IS CORRECT WITH AN AC VOLTMETER BEFORE YOU CONNECT IT TO THE INTEGRATOR.

CAUTION

EARTH GROUND MUST BE PROVIDED TO THE INTEGRATOR. DO NOT USE CONDUIT TO PROVIDE THIS GROUND.

CAUTION

A READILY ACCESSIBLE DISCONNECT DEVICE (MAXIMUM 20 AMP) SHALL BE INCORPORATED IN THE FIELD WIRING. THIS DISCONNECT DEVICE SHOULD BE IN EASY REACH OF THE OPERATOR AND IT MUST BE MARKED AS THE DISCONNECTING DEVICE FOR THE EQUIPMENT.

CAUTION

REFER TO THE FIELD WIRING DIAGRAM (FIGURE 2-7) AS A GUIDE IF YOU DO NOT HAVE A SPECIFIC WIRING DIAGRAM FOR YOUR SYSTEM. FOLLOW YOUR LOCAL ELECTRONIC CODES AND REGULATIONS FOR MINIMUM WIRE SIZE AND ROUTING.

FIELD WIRING DIAGRAM FIELD MOUNT WITHOUT FIELD TERMINAL BOARD OR PANEL MOUNT FIGURE 2-7

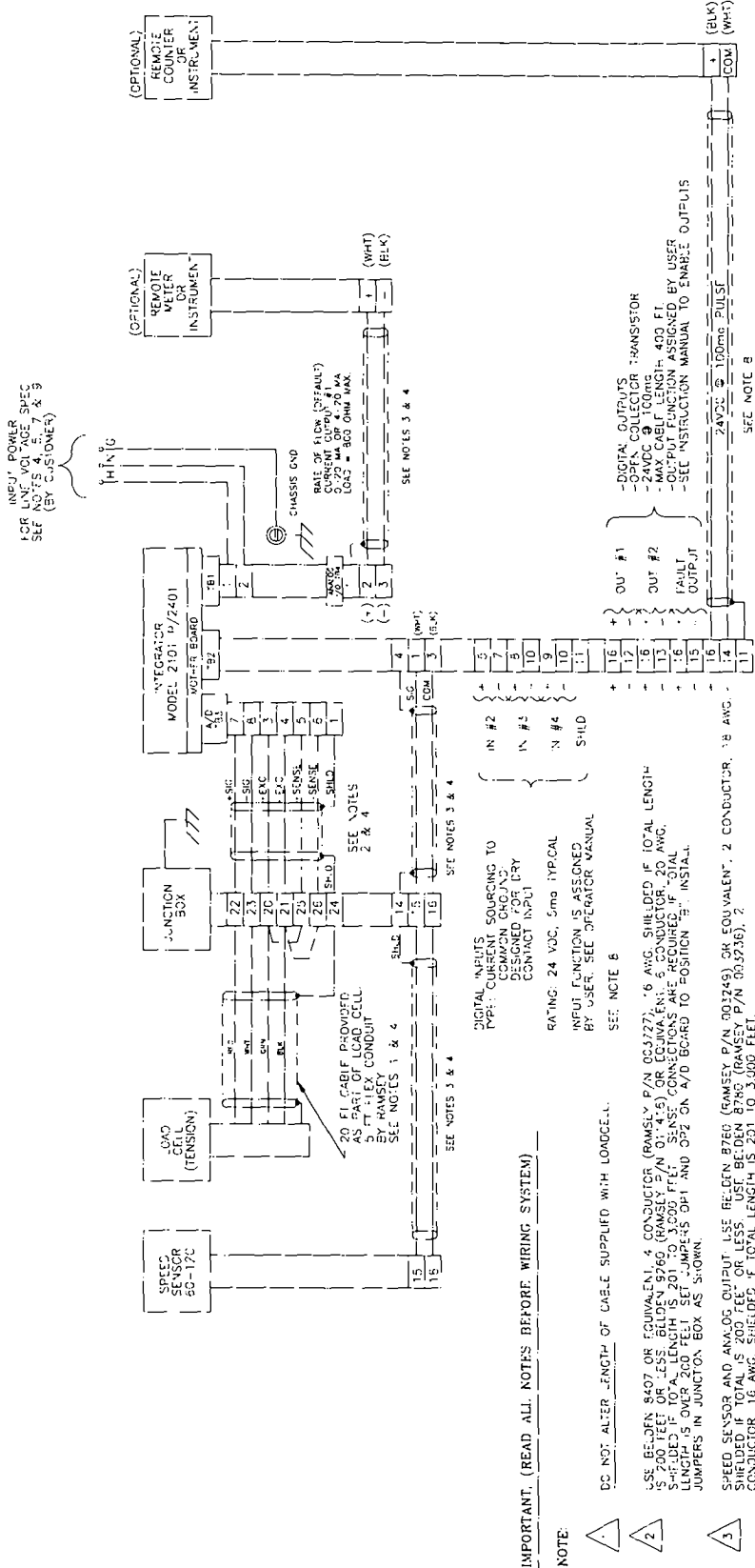

A00708a

2.3.5 Wiring

1. Some critical wiring considerations:
 - A. Insure power is off.
 - B. Do not route load cell and signal cables in the same conduit with power cables or any large source of electrical noise.
 - C. Wiring should be long enough, and routed to allow the chassis to be removed from the front for servicing if necessary.
 - D. Connect the shields ONLY where shown.
 - E. Check that all wires are tight in their connections.
 - F. Earth ground all enclosures and conduit.
 - G. Never use a "megger" to check the wiring.
 - H. A readily accessible disconnect device (maximum 20 amps) shall be incorporated in the field wiring. This disconnect should be in easy reach of the operator and it must be marked as the disconnecting device for the equipment.

2. To connect incoming power, use the following procedure (see Figure 2-5).

NOTE: All units shipped from the factory are configured for 120 VAC. If another input selection is desired, refer to Section 2.4.1 (Mother Board Configuration Jumpers and Switches).

- A. For input power, use 14 AWG stranded wire.
- B. Wire the safety ground terminal located on the right back side of the enclosure.
- C. Wire the HOT to terminal labeled HOT.
- D. Wire the NEUTRAL to the terminal labeled NEUTRAL.

2.4 INTEGRATOR CONFIGURATION

The Micro-Tech 2101 is one of a family of products that is supported by a common hardware platform. Configuration of the hardware platform and additional circuit boards enable the hardware platform to be used for several discrete instruments.

Wire jumpers are installed at the factory for the instrument ordered, and should not have to be reconfigured in the field.

Switches and removable jumpers are described in this section. The default position is noted in each description and, in most cases, is not changed.

2.4.1 Mother Board Configuration Jumpers and Switches



TO BE PERFORMED BY QUALIFIED SERVICE PERSONNEL ONLY.

1. AC voltage input power selection SW1 and SW2 are located on the right center section of the mother board (see Figure 2-8).

	AC INPUT VOLTAGE	FUSE F1 (SB)	SW1 SETTING	SW2 SETTING
Default	110	1.0 A	110	110/220
	120	1.0 A	110	120/240
	220	0.5 A	220	110/220
	240	0.5 A	220	120/240

First, set SW1 for nominal 110 VAC or 220 VAC. Next, set SW2 close to the actual input voltage.

Example: Input Voltage = 117 VAC
SW1 = 110
SW2 = 120/240

2. General Purpose Digital Inputs

Located on the Field Terminal board are provisions for three programmable status input optional OPTO/22 plug-in modules. The programmable inputs may be configured as normally open or normally closed. External AC or DC power for input logic is required.

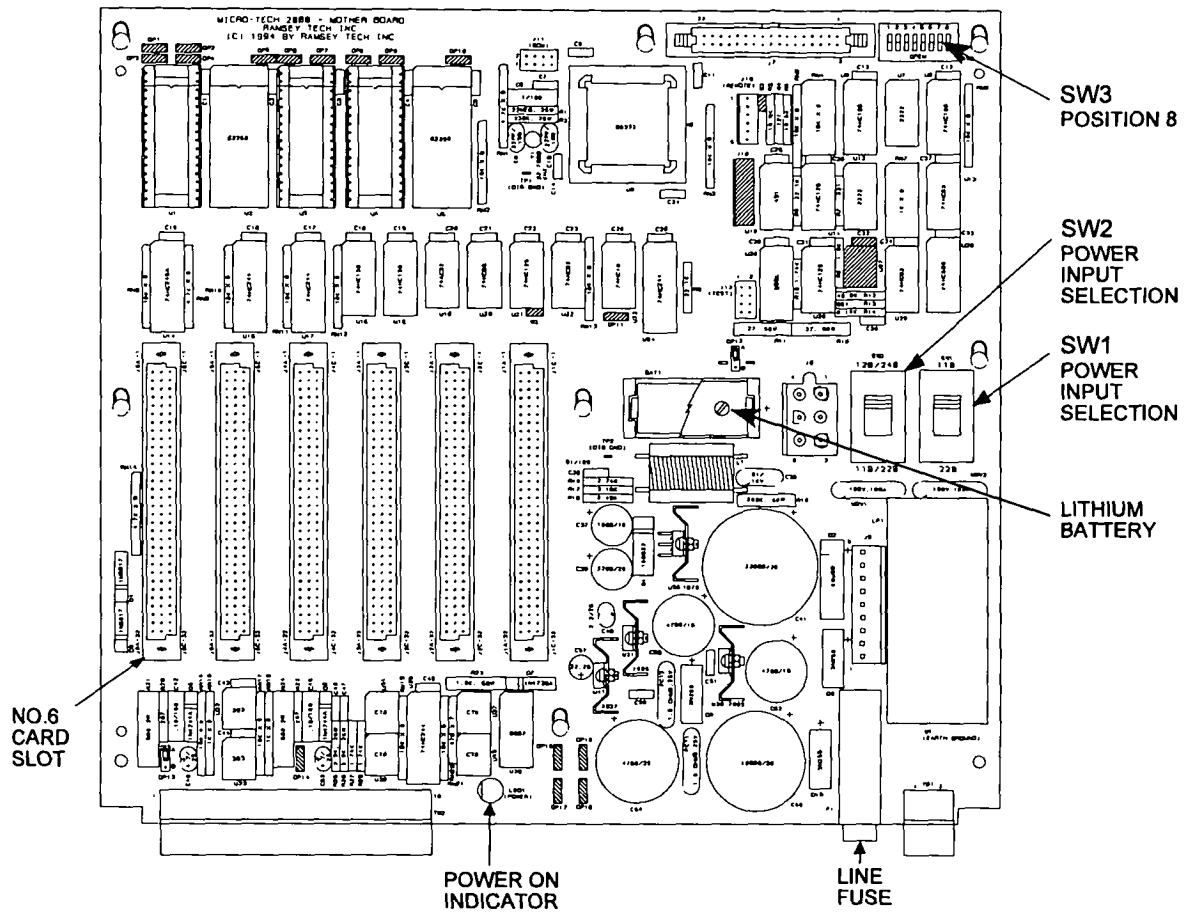

A00926b

MODEL 2101 MOTHER BOARD
FIGURE 2-8

The programmable input choices are:

- External Alarm 1
- External Alarm 2
- External Alarm 3
- Print
- Belt Running
- Reset Total
- Reset Alarm
- Auto Zero
- Clip Detector
- Batch Start Command
- Batch Stop Command
- Batch Standby Command
- Calibration Select 1...10

Any three inputs may be selected. An optional AC or DC OPTO/22 module is required for each input.

3. Digital Outputs

Located on the Mother board are provisions for four programmable output OPTO/22 plug-in modules. Three digital outputs are programmable and the fourth one is permanently assigned as integrator fault. The three programmable digital outputs may be configured as normally open or normally closed. The fault output is normally closed and cannot be reconfigured or used as a programmable output. External AC or DC power is required for all external devices wired to the output modules. One OPTO/22 AC output module is included for remote totalization.

The programmable output choices are:

- Alarm Cumulative
- Shutdown Cumulative
- Ready
- High Load
- Low Load
- High Rate
- Low Rate
- High Speed
- Low Speed
- Totalization Pulse (Remote Counter)
- Batch Preset Reach
- Batch End
- Print Ready
- Load WTS (Weights)
- Out of Range
- Deviation Alarms

2.4.2 Field Terminal Board (Field Mount Only)

The field terminal board is not available on the panel mount version. An optional solid-state module rack is required to interface with the panel mount version when solid-state modules are required (see Figure 2-10).

NOTE: You must choose between wiring dry contact inputs and open collector outputs direct or through the solid-state relay module options. The two options cannot be mixed.

2.4.3 A/D Board Jumpers

1. Load Cell Sense

Load cell sense is controlled by selectable jumpers OP1 and OP2 located on the lower left corner of the A/D board located in Mother board slot #6 (Figure 2-9). The jumpers should be in position "A" local sense if the distance is less than 200 feet between load cell and integrator.

For distances greater than 200 feet and less than 3,000 feet, the jumper should be in position "B". A special 6 wire cable is required. Refer to the field wiring drawing for jumper requirement in the scale junction box.

JUMPERS		
Mode	OP1	OP2
Less than 200 feet	"A"	"A"
Greater than 200 feet	"B"	"B"

[Default]

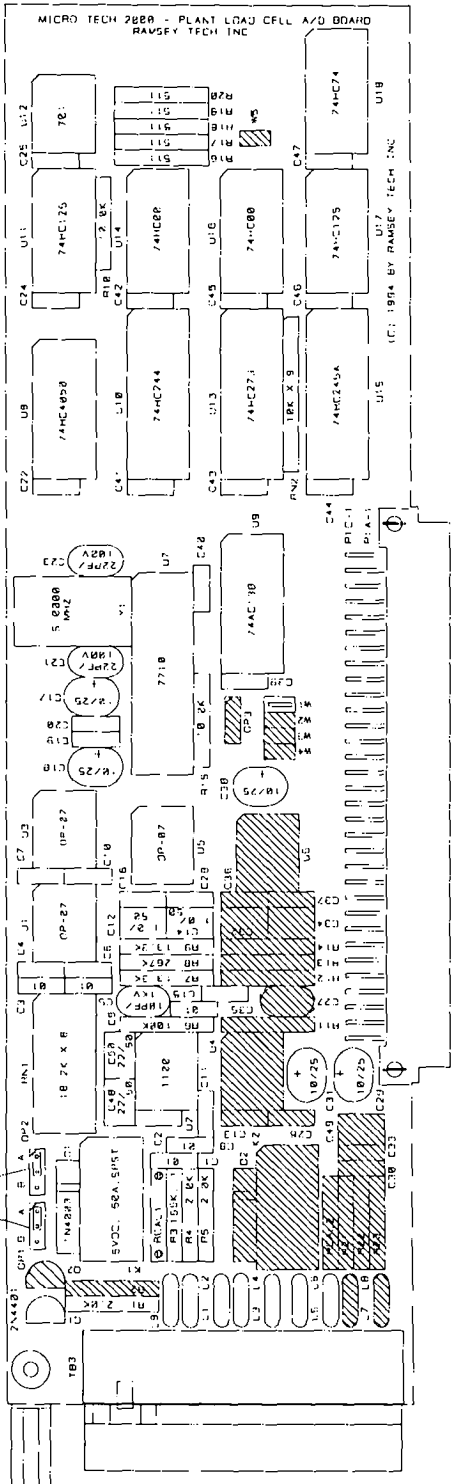

OP1 & OP2

LOAD CELL A/D BOARD
FIGURE 2-9

A00379

Solid-State Relay Sockets
W1 through W10 Wire Jumpers

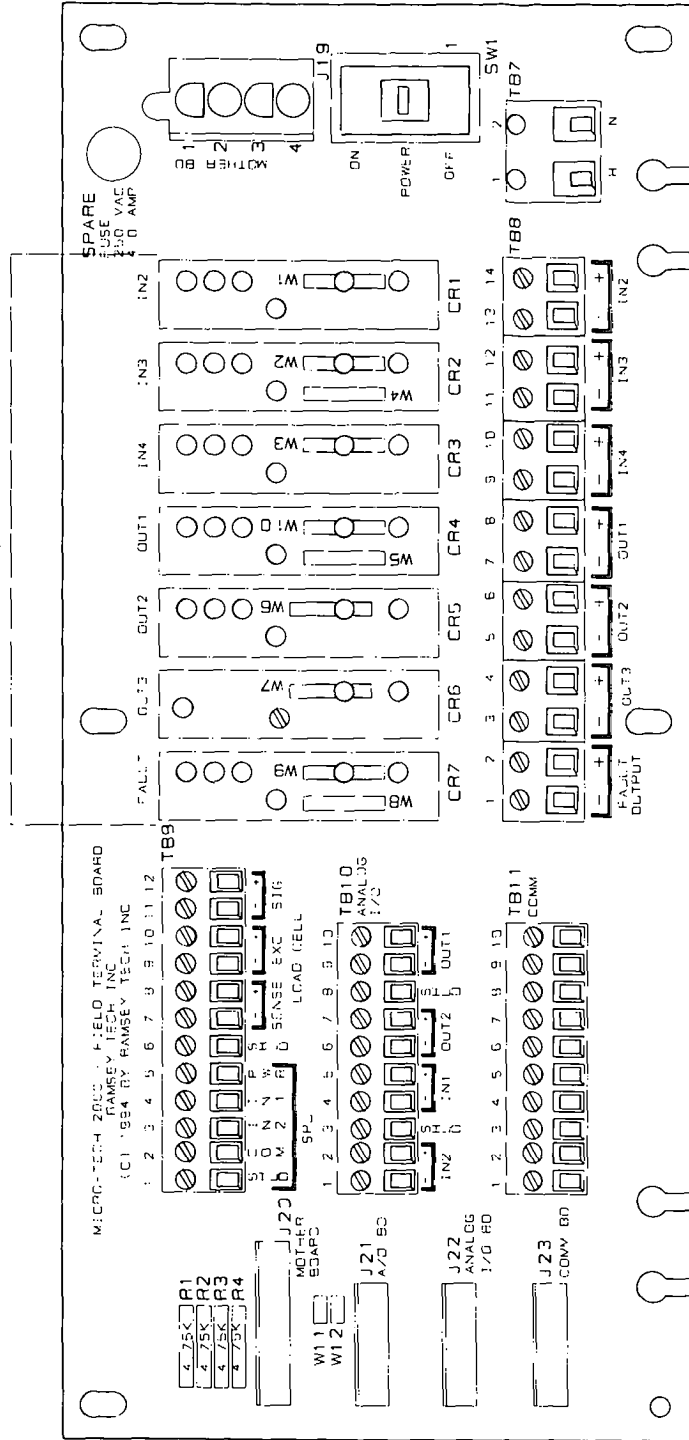

FIELD TERMINAL BOARD
FIGURE 2-10

A00381

2.4.4 Analog Input/Output Board

The optional analog input/output board is available in two configurations described below. (A) has one current output only; whereas, (B) has two voltage inputs and two current outputs (Figure 2-11). The Micro-Tech 2101 can support up to four current outputs. Four outputs require two (B) analog boards.

No configuration switches or jumpers exist on the current output board.

The integrator is supplied with a type (A) one current output only board located in Mother board slot #5. An additional Type A or Type B board can be added at any time.

Type A. One user definable 0-20/4-20 or 20-4/20-0 mA output.

Rate
Speed, or
Load

Type B. Two +/- 5 VDC differential inputs and two user definable 0-20/4-20 or 20-4/20-0 mA outputs (optional).

Inputs
Incline Compensation
Moisture Compensation

Outputs
Rate
Speed, or
Load

2.4.5 Communications Board Configuration

See REC 3949 Serial Communications manual if Communication Board A is installed.

2.4.6 Load Out Option

See Appendix A/5 if the load out board is installed.

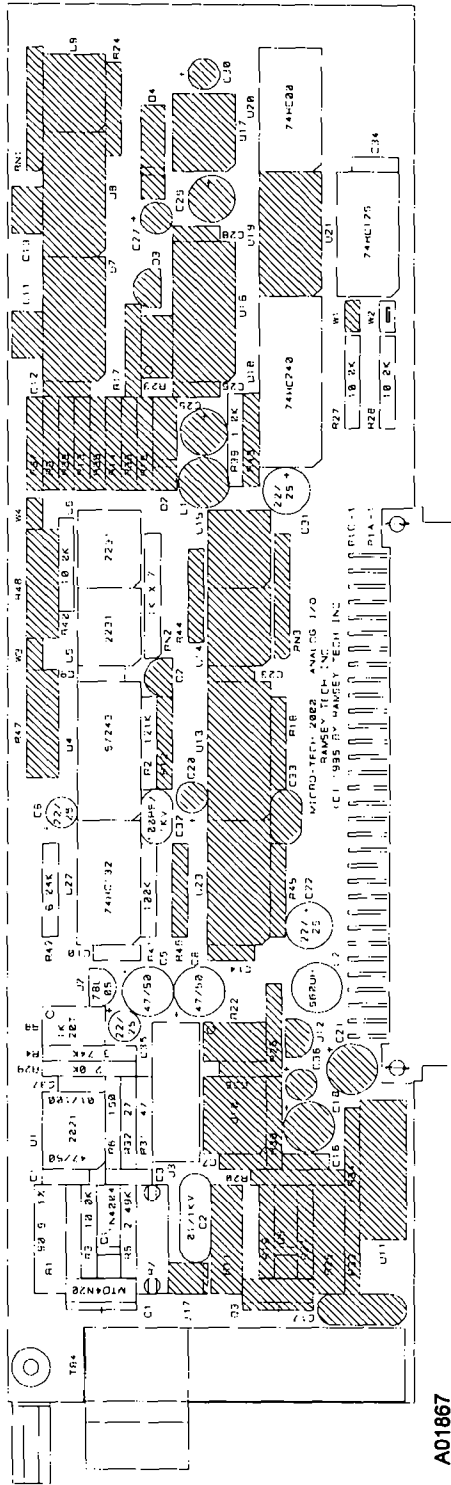

A01867

Depopulated 1 Output

ANALOG I/O BOARD
FIGURE 2-11

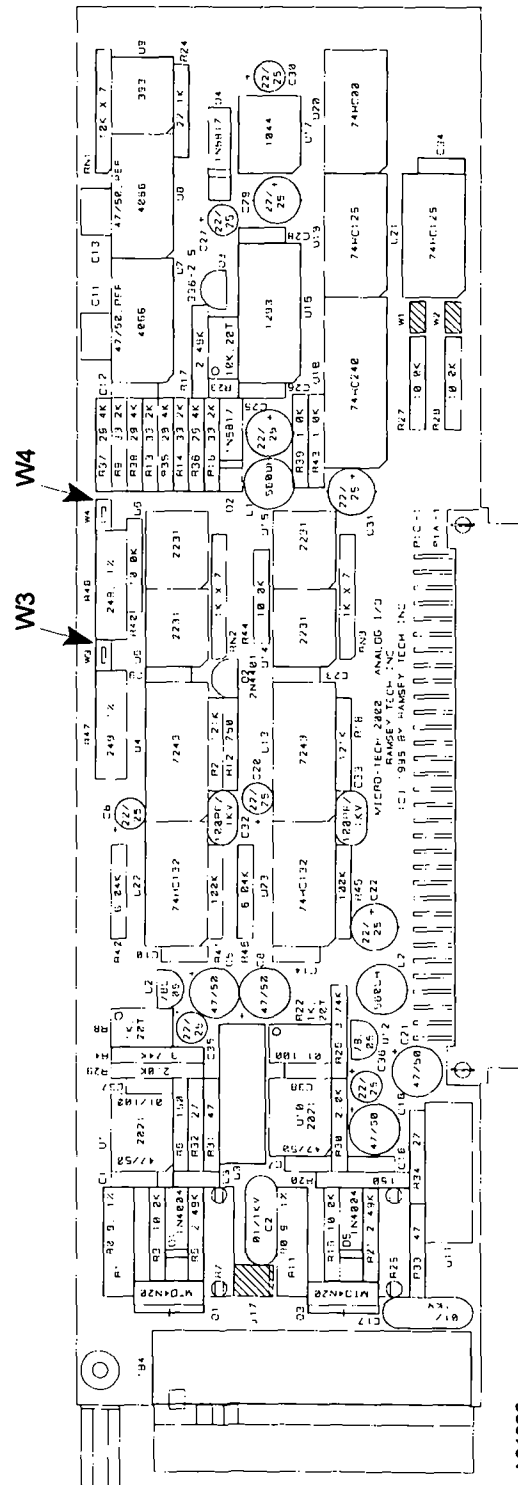

A01868

Populated 2 Inputs / 2 Outputs

2.5 INITIAL SETUP PROCEDURE

Following mechanical and electrical installation, it is necessary that you program field data that is specific to your application into the Micro-Tech 2101 Integrator memory. The following setup procedure should be completed before calibration of your belt scale system is attempted. Refer to Chapter 3 of this manual if more details or assistance is necessary.

2.5.1 Determining Installation Parameters

Before turning on the conveyor belt or applying power to the belt scale system, it is necessary to complete the following statements. Refer to your System Data Sheet in the front of your belt scale manual (see Figure 2-12).

1. Scale Capacity

Determine the scale's capacity in tons per hour and record the capacity below. (Example: 400.0)

_____ (Tons Per Hour)

2. Belt Scale Code Number

Determine the belt scale's code number from the System Data Sheet located in front of the scale manual or see Appendix A/1, Weighbridge Parameters. Record the code number below. (Example: code number one is a belt scale model 10-20-1 for conveyor width 18 through 36 inches.) Enter 0 for any weighbridge not found in the table.

_____ (Belt Scale Code Number)

Entering the code number enters a list of default parameters for the weighbridge selected. During initial programming, the Integrator calculates a calibration constant for R-Cal based on the default values. If test weights or test chains are used, their weight values are entered in the Cal Data Scroll after initial programming is completed.

During initial programming, DETAIL can be selected after entering the belt scale code number. All weighbridge default values can be viewed by scrolling down. A parameter can be changed at this time if necessary.

NOTE: Entering code 0 or selecting DETAIL requires all measurements in Steps 3 through 14 below to be made and entered during initial programming.

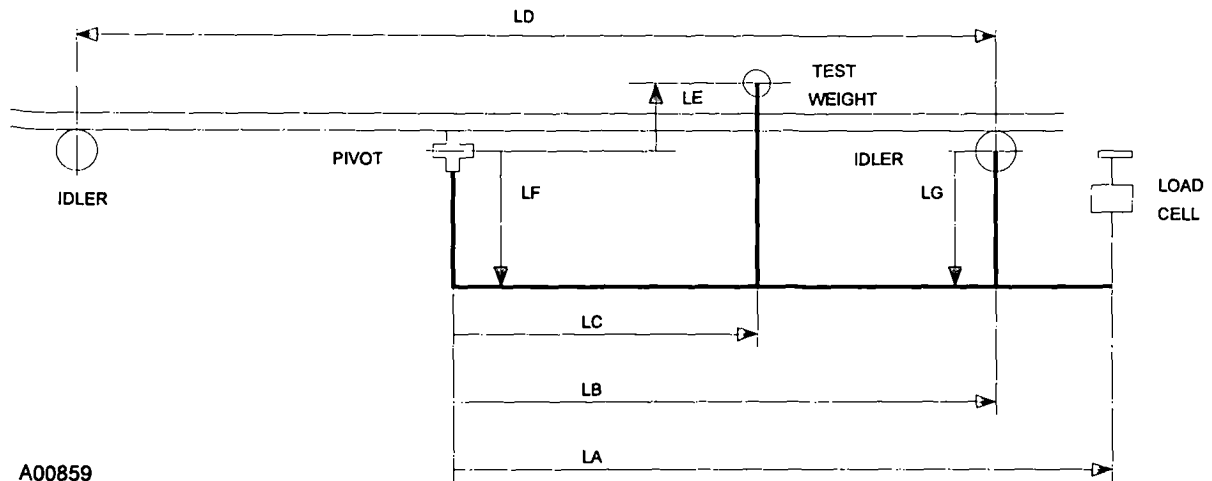

A00859

BELT SCALE WEIGHBRIDGE
FIGURE 2-12

- | | | |
|-----|-------------------------------|-------|
| 3a. | PIVOT TO LOAD CELL | (LA) |
| 3c. | PIVOT TO 1° IDLER | (LB1) |
| 3d. | PIVOT TO 2° IDLER | (LB2) |
| 3e. | PIVOT TO 3° IDLER | (LB3) |
| 3f. | PIVOT TO 4° IDLER | (LB4) |
| 3g. | PIVOT TO 5° IDLER | (LB5) |
| 3h. | PIVOT TO 6° IDLER | (LB6) |
| 4. | PIVOT TO TEST WEIGHT LENGTH | (LC) |
| 5. | PIVOT TO TEST WEIGHT HEIGHT | (LE) |
| 8. | IDLER SPACING | (LD) |
| 6. | PIVOT TO CARRIAGE HEIGHT | (LF) |
| 7. | CARRY ROLL TO CARRIAGE HEIGHT | (LG) |
| 9. | CONVEYOR'S ANGLE | (θ) |
| 3b. | IDLERS NUMBER | (IDN) |

3. Belt Scale Weighbridge Dimensions

Refer to Figure 2-12 and the sketches below for measurements.

a. Pivot to Load Cell - LA

As indicated on Figure 2-13, measure the distance from the pivot center line to the load cell center line to the nearest 0.032 (1/32)". Record the distance below. (Example: 32.00)

_____ " (Pivot to Load Cell Distance)

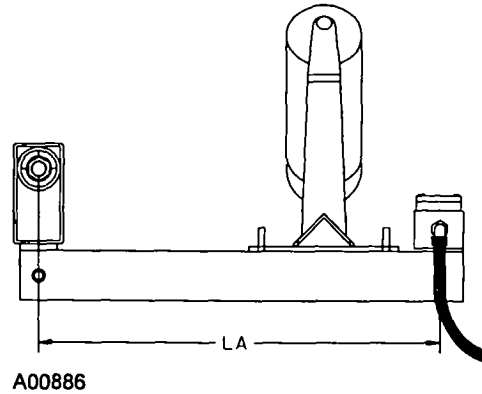

PIVOT TO LOAD CELL
FIGURE 2-13

b. Number of Weigh Idlers on Scale Weighbridge(s) - IDN

_____ (Number of Weigh Idlers)

c. Pivot to 1st Idler (Weigh Idler) - LB1

As indicated on Figure 2-14, measure the distance from the pivot center line to the weigh idler's center line to the nearest 0.032 (1/32)". Record the distance below. (Example: 24.00)

_____ " (Pivot to Weigh Idler Distance)

(Model 10-20 belt scale shown.)

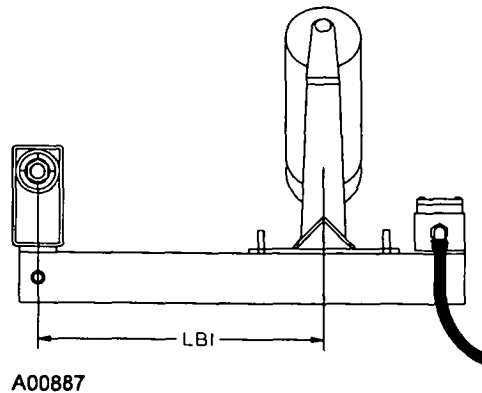

PIVOT TO 1ST IDLER
FIGURE 2-14

d. Pivot to 2nd Weigh Idler (Optional)

As indicated on Figure 2-15, measure the distance from the pivot center line to the second weigh idler's center line to the nearest 0.032 (1/32)". Record the distance below. (Example: 24.00)

_____ " (Pivot to 2nd Weigh Idler Distance)

(Model 10-22 belt scale, 10-17-2 similar.)

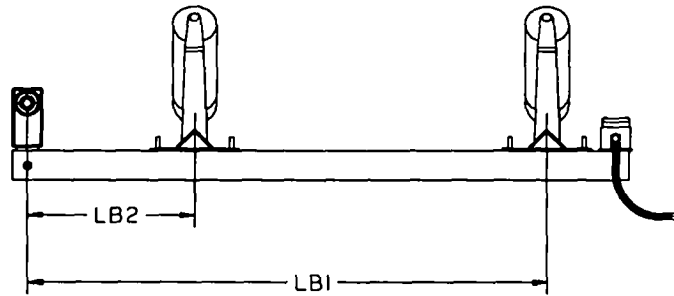

A00888

PIVOT TO 2ND WEIGH IDLER
FIGURE 2-15

NOTE: Up to six (6) weigh idlers on a single weighbridge may be entered during programming. Measure and record the same as step d above for each additional weigh idler.

e. Pivot to 1st, 2nd, 3rd and 4th Idler (Weigh Idler)

As indicated on Figure 2-16, measure the distance from the pivot center line to the weigh idler's center line to the nearest 0.032 (1/32)". Record the distance below. (Example: 24.00)

_____ " (Pivot to Weigh Idler Distance)

(Model 10-17-4 belt scale shown.)

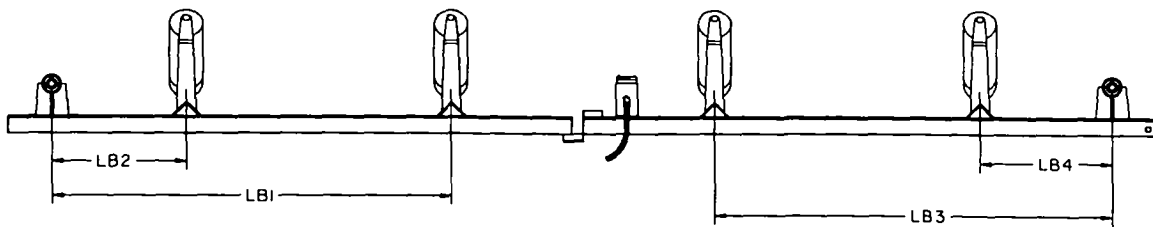

A00889

PIVOT TO 1ST, 2ND, 3RD AND 4TH IDLER
FIGURE 2-16

NOTE: Complete Steps 4, 5, 6, and 7 below only if test weights are used for calibration.

4. Pivot to Test Weight Height - LE

Measure the distance from the centerline of the pivot to the actual point of test weight contact to the nearest 0.032 (1/32) inch (Figure 2-17). Record the distance below. If contact point is below pivot, value is negative (-).

(Example: 0.00) If test weights are not used, disregard this measurement.

_____ " (Pivot to Test Weight Height Distance)

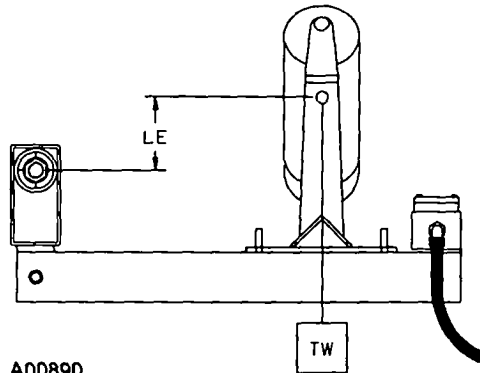

A00890
PIVOT TO TEST WEIGHT HEIGHT
FIGURE 2-17

5. Pivot to Test Weight Length - LC

Measure the distance from the centerline of the pivot to the actual point of test weight contact to the nearest 0.032 (1/32) inch (Figure 2-18). Record the distance below.

(Example: 4.75) If test weights are not used, disregard this measurement.

_____ " (Pivot to Test Weight Length Distance)

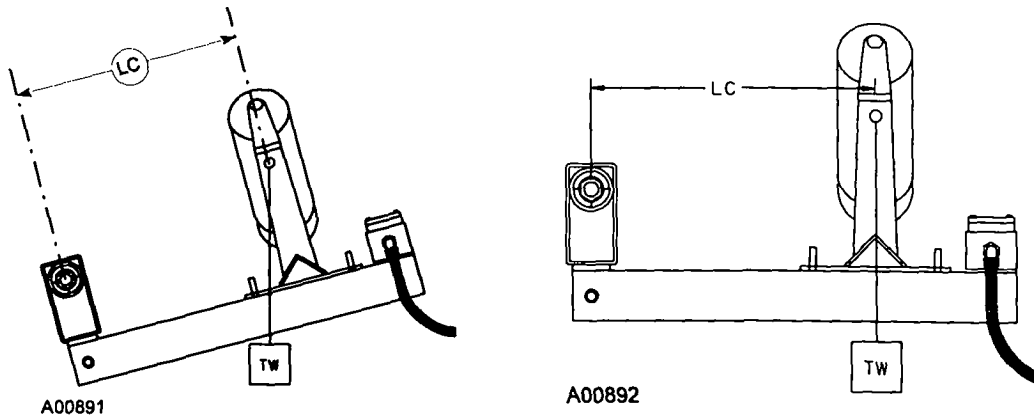

A00891
A00892
PIVOT TO TEST WEIGHT LENGTH
FIGURE 2-18

6. Pivot to Carriage Height - LF

Measure the distance from the centerline of the pivot to the top of the carriage rails to the nearest 0.032 (1/32) inch (Figure 2-19). Record the distance below. (Example: 6.50)

_____ " (Pivot to Carriage Height Distance)

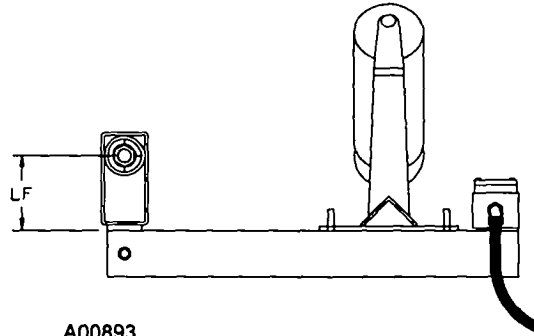

A00893
PIVOT TO CARRIAGE HEIGHT
FIGURE 2-19

7. Roll to Carriage Height - LG

Measure the distance from the top of the carriage rails to the top of the weigh idler carry roll where the belt makes contact on trough idlers (Figure 2-20). Flat idlers measure to the centerline of the grease fitting to the nearest 0.032 (1/32) inch. Record the distance below. (Example: 6.50)

_____ " (Roll to Carriage Height Distance)

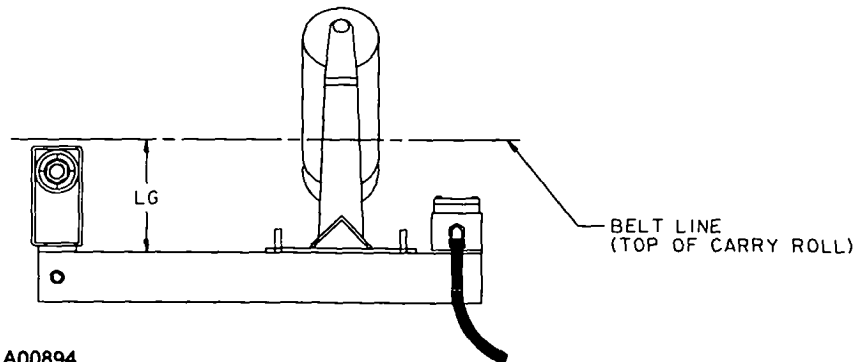

A00894
ROLL TO CARRIAGE HEIGHT
FIGURE 2-20

8. Number of Load Cells

Enter the number of load cells. (Example: 1)

_____ (Number of Load Cells)

9. Idler Spacing Scale Area - LD

Measure the distances between the center lines of all idlers from the plus 1 (+1) to the minus 1 (-1) idler on both sides of the conveyor (left and right). Add all the measurements together and divide by the number of measurements to determine the average distance.

NOTE: If the distances measured is not all equal within 0.032 (1/32)" the scale is not properly installed. Refer to the belt scale installation manual provided.

_____ " (Idler Spacing)

10. Conveyor's Angle of Incline

Measure the conveyor's angle of incline to the nearest 0.1 degrees. Record the degree of angle below. (Example: 16.0) Refer to Figure 2-21 for more information on how to measure angle of incline.

_____ degrees (Angle of Conveyor Incline)

11. Load Cell Capacity

From the belt scale data sheet located in the front of its manual, determine the load cell size in pounds. Record the weight below. (Example: 250.0)

_____ pounds (Load Cell Weight)

12. Load Cell Sensitivity

From the load cell name plate, determine the load cell sensitivity in mV/V. Record the sensitivity below. (Example 3.000 mV/V)

_____ (Load Cell Sensitivity)

13. Load Cell Resistance

Measure the signal (output) resistance of each load cell with a digital VOM. Record the resistance below. (Example: 350.000)

_____ (Load Cell Resistance)

14. Conveyor Belt Length

Using a long tape measure, measure the length of one complete belt revolution. Measure to the nearest 0.1 foot. Record the length below. (Example: 1000.0)

_____ feet (Conveyor Belt Length)

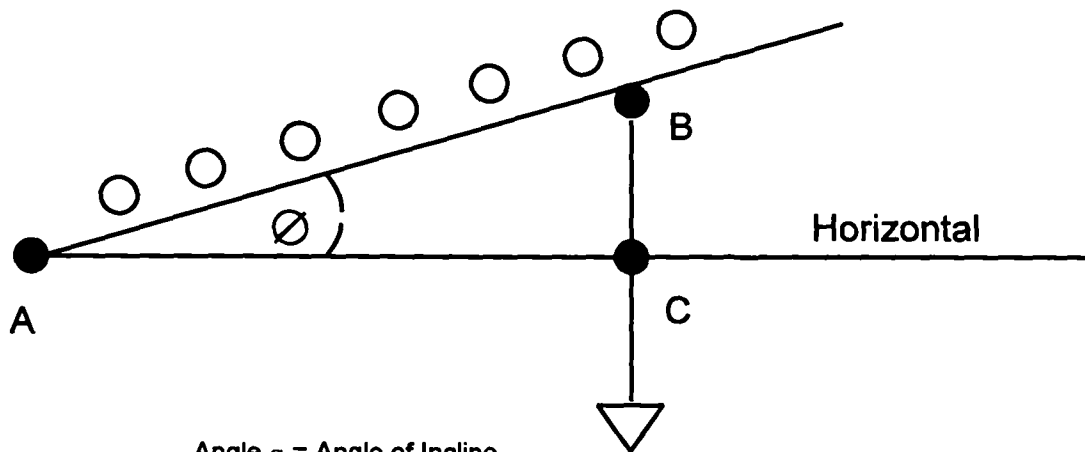

Angle ϕ = Angle of Incline

$$\text{COS } \phi = \frac{\text{Distance AC}}{\text{Distance AB}}$$

A00568

MEASURING ANGLE OF INCLINE
FIGURE 2-21

Choose a convenient distance 'AB' and measure it in inches.

Hang a plumb line from 'B'.

Measure the horizontal distance from 'A' to plumb line in inches ('AC'). Divide 'AC' by 'AB' to get $\text{COS } \phi$.

If angle of incline in degrees is known, use the following table.

Angle ϕ	Cos ϕ
0	1.0000
1	.9998
2	.9994
3	.9986
4	.9976
5	.9962

Angle ϕ	Cos ϕ
6	.9945
7	.9925
8	.9903
9	.9877
10	.9848
11	.9816

Angle ϕ	Cos ϕ
12	.9781
13	.9744
14	.9703
15	.9659
16	.9613
17	.9563

2.5.2 Programming the Micro-Tech 2101 Integrator

When power is first applied to the Integrator, the system steps the operator through menus and options that bring the system to a weighing state. Soft keys, numeric keys and the scroll control keys are used to select choices. The **RUN** and **MENU** control keys are inactive during this procedure.



Inside the Integrator's front panel are two voltage selection slide switches (see Figure 2-22). Ensure they are in the correct position -- either 110/120 or 220/240 VAC -- before applying power or equipment damage will occur. See Section 2.4.

1. Turn the belt scale conveyor belt on. Run the conveyor empty during setup and calibration.

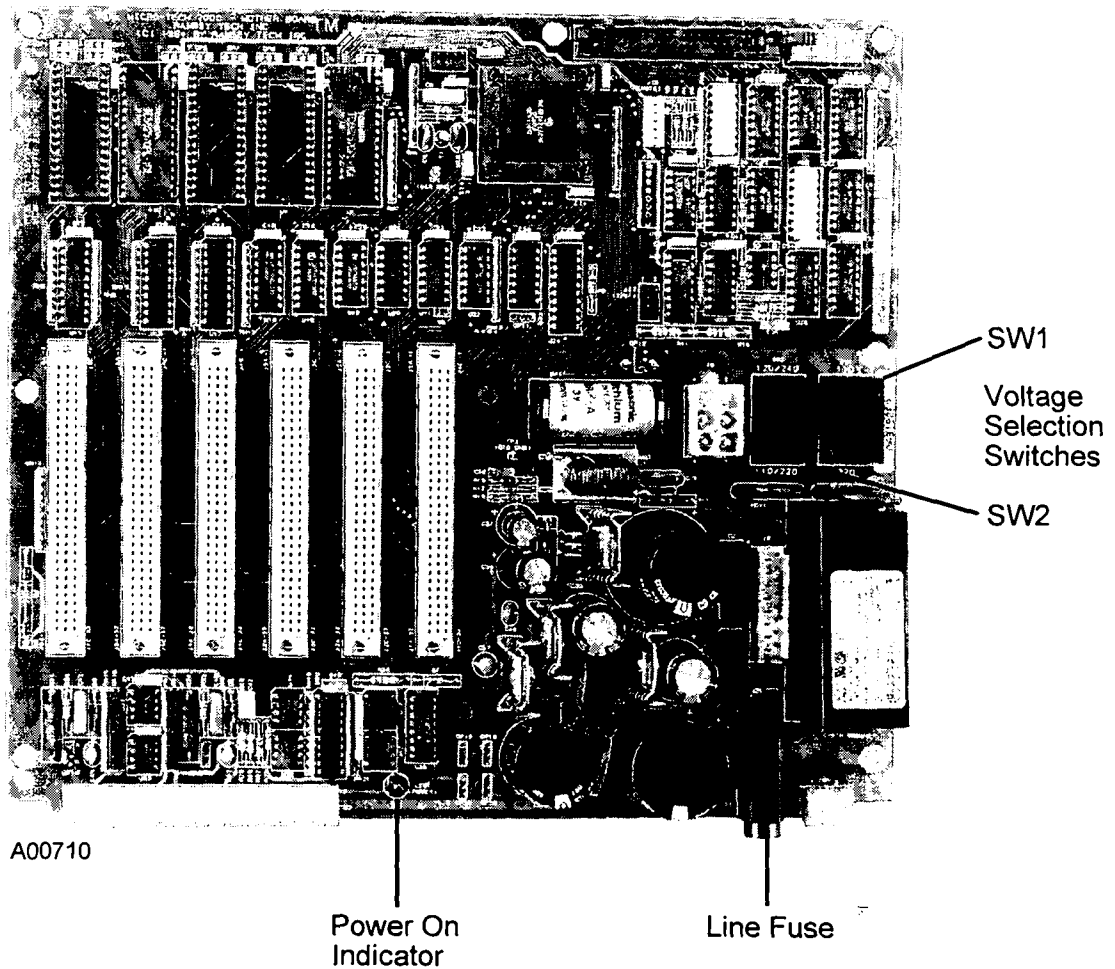

MICRO-TECH 2101 CPU BOARD
FIGURE 2-22

2. Programming the Integrator

The programming mode begins the first time power is applied. Information requested by the instructional screens should be entered before moving to the next screen. The belt scale is calibrated at the end of this procedure provided the correct information is entered. The alarm light flashes during the programming procedure and clears when calibration is complete.

The programming mode begins with the following instructional screens.

```
- MEMORY ERASED -  
Choose the language  
key to continue to  
ESP           USA
```

The Micro-Tech 2000 is a dual language instrument. USA is always the first language. The standard configuration provides Spanish (ESP) as the second language. Other languages, such as German (GER), are available upon request (consult factory). Press the desired language.

```
Initial scale setup  
and calibration.  
Press down SCROLL.
```

Press the **DOWN SCROLL** key.

```
Press key under HELP  
for more information  
  
HELP
```

"HELP" is flashing

Press the **HELP** soft key.

```
Key with dot (soft  
key) performs action  
of word above it.  
MORE   RETURN
```

When **RETURN** is pressed, the user is returned to the previous screen. Pressing **MORE** advances the system to the next screen.

Press the **MORE** key.

```
Use down SCROLL key
to advance through
the menus.
MORE   RETURN
```

Pressing **MORE** or **RETURN** reverts the screen back to previous screens in this series.

Press the **DOWN** scroll key.

3. Press **SCROLL DOWN** key to accept the default unit, or **CHOICES** soft key to scroll selections. Press **ENTER** to confirm your selection. Scroll down.

```
- DISPLAY SCROLL 1 -
Measure units
> English <
CHOICE ENTER
```

Default: ENGLISH
Selections: ENGLISH, METRIC, MIXED
If English, all units in English
If Metric, all units in Metric
If Mixed, units may be a combination of English and Metric

NOTE: If the Measure units are changed from English to Metric (or vice versa) after the scale is calibrated, the span number will change but the calibration will remain the same.

4. The units to be used for totalization are selected here. Press **ENTER** soft key to accept the default unit, or **CHOICES** soft key to scroll selections. Press **ENTER** to confirm your selection. Scroll down.

```
- DISPLAY SCROLL 2 -
Totalization Units
> Tons <
CHOICE ENTER
```

If ENGLISH: Default: Tons
Selections: Tons, LTons, Pounds
If METRIC: Default: tonnes
Selections: tonnes, kg
If MIXED: Default: Tons
Selections: Tons, LTons, kg, Pounds, tonnes

5. Units used for parameters expressed in length are selected here. Selections are only available if **MIXED** units are in use. Press **ENTER** soft key to accept the default unit, or **CHOICES** soft key to scroll selections. Press **ENTER** to confirm your selection. Scroll down.

```
- DISPLAY SCROLL 3 -  
Length Units  
> feet <  
CHOICE ENTER
```

If ENGLISH: Default: Feet
If METRIC: Default: meters
If MIXED: Default: Feet
Selections: Feet, meters

6. The rate is displayed according to the units selected here. Press **ENTER** soft key to accept the default unit, or **CHOICES** soft key to scroll selections. Press **ENTER** to confirm your selection. Scroll down.

```
- DISPLAY SCROLL 4 -  
Rate Units  
> TPH <  
CHOICE ENTER
```

If ENGLISH: Default: Tph
Selections: Tph, LTph, Lb/mn, T/mn, LT/mn, Percent %, Lb/h
If METRIC: Default: kg/h
Selections: t/h, kg/m, t/m, Percent %, kg/h
If MIXED: Default: Tph
Selections: Tph, LTph, kg/m, t/m, Lb/m, t/mn, Lt/mn, Percent %, kg/h, t/h, Lb/h

7. The units used for entering the load cell capacity are specified here. In this particular case, the use of English or Metric units is always allowed, even if **MIXED** is not specified. Press **ENTER** soft key to accept the default unit, or **CHOICES** soft key to scroll selections. Press **ENTER** to confirm your selection. Scroll down.

```
- DISPLAY SCROLL 5 -  
Load cell Units  
> Pounds <  
CHOICE ENTER
```

If ENGLISH or MIXED: Default: Pounds
If METRIC: Default: kilograms
Selections: Lbs, kg

8. The next entry is the scale capacity, which is the maximum rate at which the scale is allowed to work. This entry also defines the default number of decimal places that are used for displaying rate. Use numeric keys for entering the number, confirm with **ENTER**. Scroll down.

```

- SC DATA SCROLL 1 -
Max. scale capacity
500.0 Tph
ENTER

```

Default: 500.0
Min: 1
Max: 200000

9. When the Scale capacity is entered, the number of decimal places is also defined. If, for example, the User enters 500.0, this sets the "Scale Divisions" parameter to 0.1. Advancing to the next scroll, the User then sees first the Scale Division corresponding to the just entered Scale Capacity (in the example 0.1). If required, the User is able to alter the Scale Division to any of the available options.

Press the **ENTER** soft key to accept the default divisions, or the **CHOICES** soft key to scroll selections. Press **ENTER** to confirm your selection. Scroll down.

```

- SC DATA SCROLL 2 -
Scale divisions
> 0.1 <
CHOICE ENTER

```

Default: 0.1
Selections: 0.1, 0.2, 0.5, 1, 2, 5, 10, 20, 50, 0.01, 0.02, 0.05, 0.001, 0.002, 0.005

10. Selecting the Weighbridge Model

By entering the code number of your Ramsey scale on the next screen, the Integrator automatically calculates parameters of the system such as number of load cells and number of weigh idlers. This entry is also used for internal calibration calculations. The default model number is 1, which corresponds to belt scale model 10-20-1.

```

- SC DATA SCROLL 3 -
Belt scale code #
> 1 <
ENTER          DETAIL

```

Default: 1
Min: 0
Max: 500

Press **ENTER** to accept the displayed selection from the database listed in Appendix A/1, Weighbridge Parameters. If **ENTER** is used, the scrolls from 3A to 3J are not displayed. Skip to Step 12.

Press **DETAIL** if you want to force the following scrolls #3A to 3O to be displayed even if **ENTER** was used.

Enter **0** if you want to define the weighbridge not using the database. This should only be done for special weighbridges that are not part of the standard set of Ramsey scales. Entering **0** forces the following scrolls 3A to 3O to be displayed.

11. Detailing the Mechanical Parameters of the Frame

The following screens are only displayed if **OTHER** or **DETAIL** were pressed. Refer to Figure 2-12.

Parameter LA: pivot to Load cell distance: The distance from pivot to load cell should be measured to within 0.032 (1/32) inch (1 mm).

Using the numeric keys, enter the distance recorded in Section 2.5.1 and press **ENTER**. For weighbridges which do not have a pivot, enter zero.

```
- SC DATA SCROLL 3A-  
Pivot to load cell  
distance: 000.00 In  
ENTER
```

If ENGLISH or MIXED:	If METRIC:
Default: 32 in	Default: 1000 mm
Min: 0.00 in	Min: 0 mm
Max: 150.00 in	Max: 3800 mm

This is the **number of weigh idlers** affixed to the scale weighbridge.

```
- SC DATA SCROLL 3B-  
# of weigh idlers  
  1  
ENTER
```

Default:	1
Min:	1
Max:	6

Parameter LB1: Pivot to first weigh idler distance. Measure the distance between the pivot centerline and first weigh idler center line. Enter the distance (within 0.032 inch or 1 mm) recorded in Section 2.5.1. For weighbridges which do not have a pivot, enter zero.

```
- SC DATA SCROLL 3C-  
Pivot to 1st idler  
distance 000.00 In  
ENTER
```

If ENGLISH or MIXED:	If METRIC:
Default: 24 in	Default: 800 mm
Min: 0.00 in	Min: 0 mm
Max: 100.00 in	Max: 2500 mm

If the number of weigh idlers entered in scroll 3B is more than one, the following screens are displayed. Measure the distance between the pivot centerline and second weigh idler center line. Enter the distance (within 0.032 inch or 1 mm) recorded in Section 2.5.1. For weighbridges which do not have a pivot, enter zero.

Only if # of weigh idlers ≥ 2 :

```
- SC DATA SCROLL 3D-  
Pivot to 2nd idler  
distance 000.00 In  
ENTER
```

If ENGLISH or MIXED:	If METRIC:
Default: 0.00 in	Default: 0 mm
Min: 0.00 in	Min: 0 mm
Max: 100.00 in	Max: 2500 mm

Only if # of weigh idlers ≥ 3 :

```
- SC DATA SCROLL 3E-  
Pivot to 3rd idler  
distance 000.00 In  
ENTER
```

If ENGLISH or MIXED:	If METRIC:
Default: 0.00 in	Default: 0 mm
Min: 0.00 in	Min: 0 mm
Max: 100.00 in	Max: 2500 mm

Only if # of weigh idlers ≥ 4 :

```
- SC DATA SCROLL 3F-  
Pivot to 4th idler  
distance 000.00 In  
ENTER
```

If ENGLISH or MIXED:	If METRIC:
Default: 0.00 in	Default: 0 mm
Min: 0.00 in	Min: 0 mm
Max: 100.00 in	Max: 2500 mm

Only if # of weigh idlers >=5:

```
- SC DATA SCROLL 3G-  
Pivot to 5th idler  
distance 000.00 In  
ENTER
```

If ENGLISH or MIXED:	If METRIC:
Default: 0.00 in	Default: 0 mm
Min: 0.00 in	Min: 0 mm
Max: 100.00 in	Max: 2500 mm

Only if # of weigh idlers =6:

```
- SC DATA SCROLL 3H-  
Pivot to 6th idler  
distance 000.00 In  
ENTER
```

If ENGLISH or MIXED:	If METRIC:
Default: 0.00 in	Default: 0 mm
Min: 0.00 in	Min: 0 mm
Max: 100.00 in	Max: 2500 mm

NOTE: All measurements must be (within 0.032 inch or 1 mm) recorded in Section 2.5.1. Enter the distance with the numeric keys and press ENTER.

Parameter LE: Pivot to test-weight height. For weighbridges which do not have a pivot, enter zero. 3I, L, M and N only apply if test weights are provided for calibration.

```
- SC DATA SCROLL 3I-  
Pivot to test-weight  
height 000.00 In  
ENTER +/-
```

If ENGLISH or MIXED:	If METRIC:
Default: 0.00 in	Default: 0.0 mm
Min: - 20.00 in	Min: - 500.0 mm
Max: + 20.00 in	Max: + 500.0 mm

Parameter LC: Pivot to test-weight length. For weighbridges which do not have a pivot, enter zero.

```
- SC DATA SCROLL 3L-  
Pivot to test-weight  
length 000.00 In  
ENTER
```

If ENGLISH or MIXED:	If METRIC:
Default: 24.00 in	Default: 0 mm
Min: 0.00 in	Min: 0 mm
Max: 200.00 in	Max: 5000 mm

Parameter LF: Pivot to carriage height. For weighbridges which do not have a pivot, enter zero.

```
- SC DATA SCROLL 3M-  
Pivot to carriage  
height 000.00 In  
ENTER
```

If ENGLISH or MIXED:	If METRIC:
Default: 6.50 in	Default: 0 mm
Min: 0.00 in	Min: 0 mm
Max: 10.00 in	Max: 250 mm

Parameter LG: Carry roll to carriage height. Measure to the center line of the weigh idler carry roll on troughing idlers, and to the top of the carry roll on flat belts. For weighbridges which do not have a pivot, enter zero.

```
- SC DATA SCROLL 3N-  
Roll to carriage  
height 000.00 In  
ENTER
```

If ENGLISH or MIXED:	If METRIC:
Default: 6.50 in	Default: 0 mm
Min: 0.00 in	Min: 0 mm
Max: 20.00 in	Max: 250 mm

Enter the **number of load cells** of your weighbridge.

```
- SC DATA SCROLL 3O-  
# of load cells  
1  
ENTER
```

Default: 1
Min: 1
Max: 6

12. Defining Dimensional Parameters of the Application

Parameter LD: Idler spacing in scale area. For better accuracy, average the distance between the idlers across the scale on both sides. Measure to within 0.032 inch or 1 mm with the numeric keys and press **ENTER**.

```
- SC DATA SCROLL 4 -  
Idler spacing  
36.00 In  
ENTER
```

If ENGLISH or MIXED:	If METRIC:
Default: 36.00 in	Default: 1000 mm
Min: 2.00 in	Min: 50 mm
Max: 120.00 in	Max: 2500 mm

Enter the **angle of inclination** of the belt conveyor. If an inclination compensator is connected to the scale, after this preliminary set up has been completed, enable the automatic angle detection in I/O definition (Main Menu 4) and calibrate the incline compensator.

```
- SC DATA SCROLL 5 -  
Conveyor's angle  
0.0 Degrees  
ENTER +/-
```

Default: 0.0
Min: -25.00°
Max: +25.00°

13. Defining the Load Cell(s)

Enter the **load cell capacity** as it appears on the label placed on the load cell.

```
- SC DATA SCROLL 6 -  
Load cell capacity  
250 Lbs  
ENTER
```

If ENGLISH or MIXED:	If METRIC:
Default: 250.0 Lbs	Default: 100 kg
Min: 1 Lb	Min: 1 kg
Max: 15000 Lbs	Max: 5000 kg

The sensitivity was entered when the belt scale code was entered. If other (0) was selected, enter the load cell sensitivity in mV/V as marked on the label of the load cell. Ramsey load cells are normally 1.800 or 3.000 mV/V.

```
- SC DATA SCROLL 7 -  
Load cell sens.  
3.000 mV/V  
ENTER
```

Default: 3.000 mV/V
Min: 0.500 mV/V
Max: 3.500 mV/V

Load cell resistance is entered on this screen. The resistance for the load cell has been recorded on the System Data Sheet in the front of your belt scale manual. (It is also stamped on the load cell cable.) Enter the ohms for the load cell. The number of scrolls depends on the number of load cells specified in scroll 30.

```
- SC DATA SCROLL 8A -  
Load cell #1 res  
350.000 Ohms  
ENTER
```

Default: 350 Ohms
Min: 10 Ohms
Max: 2000 Ohms

If # of Load Cells is 2 or more:

```
- SC DATA SCROLL 8B -  
Load cell #2 res  
350.000 Ohms  
ENTER
```

Same default and limits of load cell #1.

If # of Load Cells is 3 or more:

```
- SC DATA SCROLL 8C -  
Load cell #3 res  
350.000 Ohms  
ENTER
```

Same default and limits of load cell #1.

If # of Load Cells is 4 or more:

```
- SC DATA SCROLL 8D -  
Load cell #4 res  
350.000 Ohms  
ENTER
```

Same default and limits of load cell #1.

If # of Load Cells is 5 or more:

```
- SC DATA SCROLL 8E -  
Load cell #5 res  
350.000 Ohms  
ENTER
```

Same default and limits of load cell #1.

If # of Load Cells is 6:

```
- SC DATA SCROLL 8F -  
Load cell #6 res  
350.000 Ohms  
ENTER
```

Same default and limits of load cell #1.

14. Defining the Speed Input

The speed input screen allows the operator to select either the single speed sensor input (default value), the double speed input (to provide extra safety against speed sensor failure) or a simulated value using an internal timer.

Simulation allows operation without a speed sensor. When simulated speed is selected, a conveyor running input is required (refer to the field wiring diagram).

NOTE: If speed is selected as the third line display, the line will be blank in RUN mode when simulated speed is selected.

```
- SC DATA SCROLL 9 -  
Speed input  
> single <  
CHOICE ENTER
```

Default: SINGLE

Selections: SINGLE, DUAL, SIMULATED

15. Defining the Calibration Test Duration

Zero and Span calibrations are more accurate if executed on an entire belt revolution or multiple of it. Press either ACQUIRE or MANUAL, ACQUIRE is the recommended selection. For MANUAL, see Step 18.

```
-CAL DATA SCROLL 11 -  
Establish test  
duration  
ACQUIRE MANUAL
```

Select **ACQUIRE**. Acquire is the recommended selection.

a. Acquiring the Test Duration

When selecting FULL, use a 100 foot tape to measure the belt length to the nearest 0.1 foot. Reference a fixed point (an idler) on the conveyor when counting belt revolutions. See Section 2.5.1 for the recorded conveyor belt length.

The PARTIAL (belt length measurement) selection enables the operator to acquire test duration without the entire belt length measurement.

CAUTION

**THIS OPTION SHOULD ONLY BE USED WHEN BELT LENGTH EXCEEDS
1000 FEET.**

```
ACQUIRE TEST DUR  
Choose belt length  
measurement method.  
FULL PARTIAL
```

FULL is the recommended selection.

If **FULL** is selected, continue with Step 16 below. If **PARTIAL** is selected, skip to Step 17.

16. Full Test Duration Acquisition

If **FULL** is pressed, the operator is asked to enter the length of one belt revolution. Enter the length recorded in Section 2.5.1. Measure belt length to the nearest 0.1 feet.

```
Enter length of one  
belt revolution.  
length 1000.0 Ft  
ENTER ABORT
```

If ENGLISH or MIXED:	If METRIC:
Default: 1000.0 Ft	Default: 200.0 m
Min: 1.0 Ft	Min: 0.5 m
Max: 10000.0 Ft	Max: 3000 m

After the length of the belt has been entered, the system automatically moves to the following screen which prompts the operator to press **START** when the mark passes the reference point. Pressing **ABORT** returns the screen to Cal Data Scroll 11.

The belt must be running at the maximum speed before executing this function. If not, the prescaler will be improperly calculated.

```

Start belt. Press
START when 1st mark
passes reference.
START  ABORT

```

When **START** is pressed above, the system automatically moves to the next instructional screen. The operator presses **COUNT** each time the mark passes the reference point until minimum test load conditions are met (refer to belt scale installation manual for minimum test load requirements). When the last revolution passes the mark, the operator must press **COUNT** followed by pressing **DONE**.

Pressing **ABORT** returns the screen to Cal Data Scroll 11.

Zero Cal light illuminates indicating zero calibration is in progress.

```

Press COUNT each
time a mark passes.
00000 secs 000 revs
COUNT  ABORT  DONE

```

Pressing **ABORT** returns the screen to Cal Data Scroll 11.

When duration test is finished, the new values for length of belt and time are displayed. Press **CONTINUE**.

During the Acquire Test Duration, the Integrator performed an unassisted zero calibration and installed the new zero. Skip to Step 19.

```

TEST DURATION
Length = 0000.0 Ft
Time = 000 sec
CONTINUE

```

17. Partial Test Duration Acquisition

If **PARTIAL** is pressed, the operator is asked to enter the length between two marks on the belt.

Pressing **ABORT** returns the screen to Cal Data Scroll 11.

```
Enter length between
two marks on belt.
Length: 200.0 Ft
ENTER  ABORT
```

If ENGLISH or MIXED:	If METRIC:
Default: 200.0 Ft	Default: 50.0 m
Min: 1.0 Ft	Min: 0.5 m
Max: 10000.0 Ft	Max: 3000.0 m

After the length of the belt has been entered, the system automatically moves to the following screen which prompts the operator to press **START** when the mark passes the reference point.

The belt must be running at the maximum speed before executing this function. If not, the prescaler is improperly calculated.

Pressing **ABORT** returns the screen to Cal Data Scroll 11.

```
Start belt. Press
START when 1st mark
passes reference.
START  ABORT
```

When **START** is pressed above, the system automatically moves to the next instructional screen. The operator presses **COUNT** each time a mark passes the reference point until both marks have passed. Then press **DONE**.

Pressing **ABORT** returns the screen to Cal Data Scroll 11.

Zero Cal light illuminates indicating zero calibration in progress.

```
Press COUNT each
time a mark passes.
00000 secs 000 revs
COUNT  ABORT  DONE
```

When duration test is finished, the new values for length of belt and time are displayed. Press **CONTINUE**.

```
TEST DURATION
Length = 0000.0 Ft
Time = 000 sec
CONTINUE
```

During the Acquire Test Duration, the Integrator performed an unassisted zero calibration and installed the new zero. Skip to Step 19.

18. Manual Entry of Test Duration

This procedure allows direct entry of parameters that would otherwise be generated by the acquire Test Duration modes. This menu is generally used when the operator cannot see the belt while standing at the front panel.

If **MANUAL** is pressed, the system prompts the operator for running the belt at its maximum speed. Then press **CONTINUE**.

Pressing **ABORT** returns the screen to Cal Data Scroll 11.

```
Start belt. Press
CONTINUE when belt
is at maximum speed.
ABORT CONTINUE
```

The operator is prompted to enter the length of one belt revolution.

Pressing **ABORT** returns the screen to Cal Data Scroll 11.

```
ENTER length of one
belt revolution.
Length 000.0 FT
ENTER ABORT
```

If ENGLISH or MIXED:

Default: 200.0 Ft
Min: 1.0 Ft
Max: 10000.0 Ft

If METRIC:

Default: 200.0 m
Min: 1.0 m
Max: 10000.0 m

The number of belt revolutions to be timed is then entered.

Pressing **ABORT** returns the screen to Cal Data Scroll 11.

```
ENTER the number of
belt revolutions to
be timed 000 revs
ENTER ABORT
```

Default: 1
Min: 1
Max: 100

The next entry is the time per revolution.

Pressing **ABORT** returns the screen to Cal Data Scroll 11.

```
ENTER the time for
revolutions to pass
reference 000 sec
ENTER ABORT
```

Default: 30 sec
Min: 1 sec
Max: 16200 sec

When **ENTER** is pressed, the system times the belt travel according to the above entered parameters.

Pressing **ABORT** returns the screen to Cal Data Scroll 11.

Zero Cal light illuminates indicating zero calibration in progress.

```
Timing belt travel
000 sec

ABORT
```

When test duration test is finished, the new values for length of belt and time are displayed. Press **CONTINUE**.

```
TEST DURATION
Length = 000.0 Ft
Time = 000 sec
CONTINUE
```

During Acquire Test Duration the integrator performed an unassisted zero calibration and installed the new zero.

19. Automatic Calibration of the Scale

After Test Duration has been determined, and the scale zeroed, the integrator performs an unassisted calibration of the scale. The scale is calibrated using the parameters just entered. After this, the R-CAL (electronic calibration resistor) is used to check the integrity of the load cell. During this time, the following screen is displayed:

CALIBRATION
IN
PROGRESS

When calibration procedure is completed, the following message is displayed:

SCALE CALIBRATED
Press RUN to start
or MENU for scrolls

The Alarm light stops flashing and the Ready light illuminates.

The field data entered during this procedure enabled the Micro-Tech 2001 to perform an unassisted zero balance and span calibration. Assuming no mistakes were made, the scale is calibrated and is ready for use at this time.

NOTE: The span number was calculated from the data that was entered during this programming procedure. This span number is based on a perfect mechanical alignment of the scale and its adjacent idlers. Therefore, verify this by performing a material span calibration (Section 3.9.3) or by performing a span calibration procedure (Main Menu 1, Section 3.9.2, and Main Menu 2, Section 4.2.3, Calibration Data Scroll in Appendix A/4.)

In case the load cell is not connected or a failure is detected, the following message is displayed:

SCALE NOT CALIBRATED
Press RUN to start
or MENU for scrolls

The problem causing the calibration to be aborted must be corrected before attempting another calibration. The information entered previously is still in memory and should not have to be reentered. After the problem has been corrected, press **MENU**. Main Menu 1 should appear. If not, continue to press **MENU** until Main Menu 1 appears.

Proceed to Section 3.9, Main Menu 1, and conduct a zero calibration from Section 3.9.1 and a span calibration from 3.9.2. The scale is now calibrated using R-Cal as the simulated load. Press **RUN** to start or **MENU** for scrolls.

CHAPTER 3.0 OPERATION

3.1 GENERAL

Your Ramsey Belt Scale System is capable of accurate weighing, provided it is installed, calibrated, operated, and maintained in complete accordance with the instructions contained in this manual, along with your scale frame installation manual.

3.2 OVERVIEW

Model 2101 Integrator is a micro-computer based instrument that accepts and conditions speed and weight signals and provides visual and electrical outputs for total weight and rate of flow. A stable 10 volt DC excitation voltage capable of exciting up to six strain gauge load cells is produced by the Integrator. Sense lead terminations are also provided for six wire load cell cable.

Auto Zero Track enables the belt scale system to automatically zero itself during extended periods when the conveyor belt is running empty. Auto Zero Track is menu selectable because some installations may not desire this option. A "Z" will appear on the second line of the display to indicate the selection of this option.

Life expectancy of the RAM support battery is approximately ten years, if power is not applied. Under normal operation where power is on continuously, life expectancy will be much longer.

Errors may occur during initial calibration and their reason must be corrected during initial calibration. During normal operation, an error would most likely indicate a failure in the system or improper operation.

3.3 FRONT PANEL

The front panel (see Figure 3-1) contains the necessary status indicators and keys to enable the operator to perform calibrations and all required operations after the integrator has been configured in Section 2.4.

Front panel operation, zero calibration and span calibration are described in this chapter. A detailed description of all menus and their contents can be found in Appendix A/4.

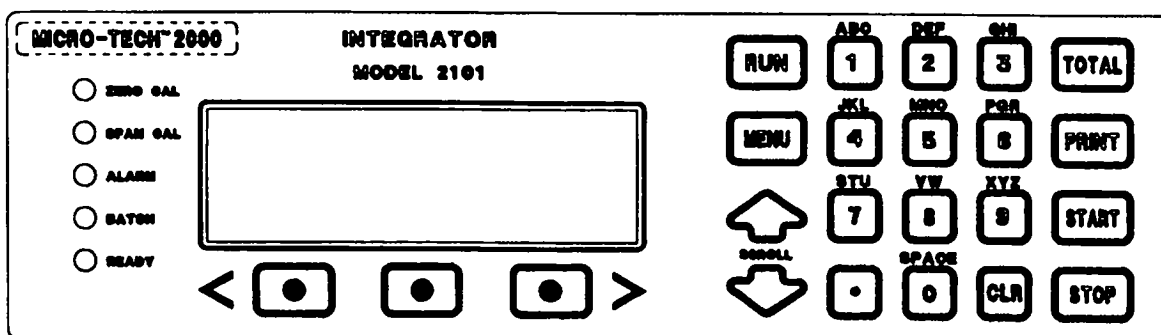

MODEL 2101 INTEGRATOR FRONT PANEL
FIGURE 3-1

3.3.1 LED Status Indicators

The five red status indicators show the status of the integrator.

1. Zero Calibration in progress.
2. Span Calibration in progress.
3. Alarm pending.
4. Batch or Load Out running.
5. Ready (powered on, no alarm, no calibration running).

3.3.2 Keyboard

1. **Run** - Access the Run Menu. Returns integrator to Run Mode whenever pressed, see Section 3.5 for detailed description.
2. **Menu** - Permits entry to menus, see Section 3.4.
3. **Up** and **Down Arrow** - Scrolls up or down in the selected menu.
4. **Soft Keys** - Select displayed function directly above the key. Moves cursor left and right during string editing.
5. **Alpha/Numeric Keys 1 through 0** - Enter numerals and letters when string editing. Similar to telephone keys.
6. **Decimal Point Key** - Enters decimal point.
7. **Clear Key** - Removes wrong entries prior to pressing **ENTER** soft key.
8. **Total** - Displays Master total, Reset total and Operator total. Operator and Reset total may be reset, see Section 3.6 for detailed description.
9. **Print** - Starts printout. COMM option is required, see Section 4.5.3 in Appendix A/4 for detailed description.
10. **Start** - Starts load out. Restart if interrupted.
11. **Stop** - Interrupts load out. Aborts load out if already interrupted.

NOTE: Start - Stop keys are only active with Load Out option.

3.3.3 Display

The four line display indicates actual running information or displays menu entry information.

3.4 MENU DISPLAYS

The integrator is a menu driven machine that allows the operator to access all setup, test and calibration parameters. Main Menu screens 1 through 6 can be accessed at anytime by pressing the **MENU** key until the desired menu screen is displayed. Menu scrolls may be selected by pressing the soft key directly below the desired scroll, and then using the Up/Down scroll key.

If the integrator is password protected, the appropriate password must be entered prior to making changes or performing routine calibration. Menus may be viewed without entering a password, but no entries are allowed unless the password is entered.

Optional menu scrolls are only available if the available option has been installed. The following screens are activated by the **MENU** key. See Appendix A/4 for detailed description of all menus.

```
-      MAIN MENU 1      -  
Press MENU for more  
ZERO  SPAN  MAT'L  
CAL   CAL   CAL
```

```
-      MAIN MENU 2      -  
Press MENU for more  
                SCALE  CALIB  
DISPLAY DATA  DATA
```

```
-      MAIN MENU 3      -  
Press MENU for more  
PROT  DIAG  TEST
```

```
-      MAIN MENU 4      -  
Press MENU for more  
I/O   ALARMS  LOAD  
DEF.  DEFIN.  OUT
```

```
-      MAIN MENU 5      -  
Press MENU for more  
COMM A  COMM B  PRINT  
                *
```

* Can be AB RIO or
PRO DP

```
-      MAIN MENU 6      -  
Press MENU for more  
AUDIT  
TRAIL  LINEAR
```

3.5 NORMAL POWER ON

When the Integrator is powered on after initial programming, the RUN Menu is displayed unless the hardware configuration has been changed.

```
          00000000 TONS
Z          000000 Tph
```

3.5.1 Hardware Configuration

If the hardware configuration detected at power on differs from the one recorded in memory, the following screen is displayed. This only happens if a circuit board has been added or removed during power off, or a board has failed.

```
-SLOT #   n  CHANGED
Acquire new
configuration ?
YES      NO
```

The screen disappears after 10 seconds if the question is not answered. The Integrator assumes the answer is **NO**. "HW CONFIG. CHANGED" alarm is on and cannot be reset. The above screen appears each time power is cycled.

If a board is removed or added, and this is a permanent change in configuration, answer **YES**.

1. A board is removed and is not replaced:

The Integrator cancels from memory the setup data of the board that is removed. If the board is added again, the setup data for the board has to be entered again.

2. A board is added:

The Integrator acquires the new hardware configuration. Setup data for the new board must be entered.

NOTE: Check the setup configuration in the I/O Definition Scroll if an I/O board is removed or added. I/O assignments change when the number of I/O boards change (see Appendix A/4).

If the reason for the message is not known, or if the change in configuration is temporary and the operator does not want to lose the original setup, answer **NO**.

1. A board is removed:

The Integrator resumes operation, retaining setup data of the board that was removed. All other boards continue working normally. No change occurs in I/O Definition.

2. A board is added:

The Integrator resumes normal operation without recognizing the new board.

If **NO** is pressed, the "HW CONFIG. CHANGED" alarm stays on.

3.6 RUN MENU

When the integrator is normally powered on after initial programming, the Run Menu is displayed. The Run Menu can always be accessed by pressing the **RUN** key on the front panel at any time.

3.6.1 Main Run

The Run Menu consists of two operations, main Run Menu and Reset Total Menu. They can be scrolled using the scroll **UP** or **DOWN** keys.

```
      00000000 TONS
Z      000000 Tph
```

The first line always displays the MASTER TOTAL, which is the number of tons totalized by the scale since installation. This number cannot be cleared.

The second line always displays the rate. A "Z" appears on the left side if the "Auto Zero Tracking" optional function is enabled in Main Menu 2 (Calibration Data Scroll) and the scale is unloaded. The "Z" is not flashing during the first half test duration, while the integrator is checking that the belt is really unloaded. Then, during a full test duration, the "Z" is flashing, indicating the integrator is averaging the signal from the load cell to accurately rezero the scale. The load must stay below the AZT max deviation setpoint during the cycle, otherwise auto zero is aborted.

The third line is by default blank, but can be programmed to show either the belt speed, the belt loading or the date and time (if the optional COMM board is installed). The selection is made in the Main Menu 2 (Display Scroll).

3.6.2 Reset Total

```
RESET  0000000 Tons
Z      0000.00 Tph

      RESET
```

The Reset Total Menu is similar to the main Run Menu except Master Total has been replaced by Reset Total. Press the **DOWN** scroll key for access.

When the **RESET** key is pressed, the following screen is displayed:

```
Do you wish to clear
RESET total?

YES    NO
```

Press "YES" to clear the total. Press "NO" to skip clearing.

3.6.3 Material Calibration

The word MAT'L flashes in the left soft key position after a material calibration if the static scale reference weight is not known. When the reference weight is known, press the MAT'L soft key to resume and complete the material calibration procedure.

3.6.4 Alarm Pending

The message ALARM appears in the right soft key if an alarm is pending. The alarm LED also is flashing.

The following menu is displayed after pressing the **ALARM** soft key.

```
ALARM      NEW
xxxxxxxxxxxxxxxxxxxxxxxxxxx
MM-DD-YYYY  HH:MM
RESET      NEXT
```

The keyword "NEW" indicates an alarm that has not been acknowledged yet. When the operator presses the **RESET** key to clear the alarm, the alarm disappears only if the reason that caused the alarm to occur does not exist any more. If the alarm is still pending, the keyword "ACK" is displayed instead of "NEW".

The third line shows the date and time only if the optional COMM board is installed.

The **NEXT** key is used to scroll between the pending alarms. The string "xxxxxxxxxxxxxxxxxxxxx" stands for one of the following alarm conditions.

1. Clock Fail
2. Load Cell Fail
3. Ram Fail
4. Rom Fail
5. Speed Sensor
6. High Load
7. Low Load
8. High Rate
9. Low Rate
10. High Speed
11. Low Speed
12. Warm Start
13. Cold Start
14. Power Down Calibrate
15. Calibrate Time
16. External Alarm 1
17. External Alarm 2
18. External Alarm 3
19. Overflow Totalizer
20. AZT Limited
21. Batch Deviation
22. BCD Error

- 23 through 28. Hardware Configuration Changed
- 29. Math Error
- 30. Printer Error
- 31. Communication Error
- 32. RIO COMM Error
- 33. PROFIBUS-DP COMM Error
- 34 through 39. Not Assigned

Refer to Chapter 4.0, Maintenance, for more information.

3.7 TOTAL KEY

The **TOTAL** key accesses menus that contain detailed information for Master Reset and Operator total tons counters.

Master cannot be reset. Reset can be reset at will without password, and Operator can be reset at will with password.

Press the **TOTAL** key for access and scroll up or down. Pressing **RUN** returns to the Run Menu.

```

RESET TOTAL
SINCE      00-00-0000
           00000000 Tons
RESET
  
```

Password: Not Required

The second line (1) is only displayed if the optional COMM board is installed, and indicates the last date when the Reset Total was cleared.

The **RESET** key allows the operator to clear the Reset Total. No password is required for this action.

The next screen is very similar to the previous one, only the Master Total is displayed instead of the Reset Total. The **RESET** key is not displayed here since the Master Total cannot be cleared.

```

MASTER TOTAL
SINCE      00-00-0000
           00000000 Tons
RESET
  
```

A load out total can also be displayed if the Load Out optional board is installed (see Load Out in Appendix A/5 if option is installed).

When the **RESET** key is pressed, the following screen is displayed:

```

Do you wish to clear
xxxxxx total?

YES    NO
  
```

xxxxxx can be RESET or OPERATOR. Press "YES" to clear the total. Press "NO" to skip clearing.

3.8 START-STOP KEYS

Enabled only if loadout option is installed.

3.9 CALIBRATION

Main Menu 1 contains the Calibration Menu. Menu 1 is selected by pressing the **MENU** key until Main Menu 1 appears. Desired calibration scrolls are selected by pressing the soft keys directly below the desired scroll.

```
-      MAIN MENU 1      -  
Press MENU for more  
ZERO      SPAN      MAT'L  
CAL       CAL       CAL
```

3.9.1 Zero Calibrate Scroll

The zeroing process is implemented as a machine directed procedure.

1. Auto Zero

```
-      ZERO CAL      -  
Run belt empty, then  
press START.  
START  EXIT  MANUAL
```

Pressing the **EXIT** soft key returns the operator to Main Menu 1. Pressing **MANUAL** advances to Step 2 below. Pressing **RUN** at any time returns to the Run Menu.

The belt must be running during Auto Zero, since a complete zeroing procedure requires at least one full revolution of the belt to be averaged.

When **START** is pressed, the following screen is displayed.

```
AUTO ZEROING  
Time remaining 0000  
Rate: 000.0 Tph  
Tot 000000 Tons
```

During Auto Zero, resolution of the total is ten times higher than normal. The number of seconds in Line 2 is calculated based on the current speed, and corresponds to the time remaining for completing the test. If the belt is not running at the moment the test is started or it is stopped during the test, a message is displayed, indicating the procedure has been aborted.

```
WARNING Belt stopped
Calibration aborted.

EXIT
```

EXIT returns to Main Menu 1. When zero is reached, the system automatically displays the following screen.

```
AUTO ZERO COMPLETE
Error ±000.00%
Change zero?
YES    NO    ADV
```

The word "COMPLETE" is flashing. Pressing ADV changes from Error % to Accumulated Weight. The percentage of error is related to full scale capacity.

Pressing NO returns the screen to Main Menu 1 without changing the zero number.

When YES is pressed, the zero number is changed and the next screen appears.

```
ZERO # CHANGED
New zero # 00000
Old zero # 00000
RUN      MENU  ADV
```

ADV changes from "Old zero" to "Rate", to "Accumulated Weight", and to "Error %".

Press MENU to repeat Auto Zero calibration. Press RUN to return to the Run Menu.

2. Manual Zero

The Manual Zero procedure shows the zero constant and allows direct entry if known. Use the ENTER key to confirm the new number.

```
-  MANUAL ZERO  -
Rate  000.0 Tph
Zero # 00000
ENTER EXIT    ADV
```

Password: Operator

Default: 40000
Min: 0
Max: 120000

The ADV key is only displayed if Auto Zero Tracking option is enabled. The AZT function accurately tracks the zero of the scale by calculating an additional zero constant. The portion of zero due to AZT is not incorporated in the zero constant, but is shown separately.

When ADV is pressed, the system scrolls between Zero and AZT:

```
-  MANUAL ZERO  -  
AZT # ±000000  
AZT % ±000000  
ENTER  EXIT  ADV
```

Password: Operator

When the AZT is displayed, the ENTER key incorporates the AZT number into the Zero constant, so the displayed AZT number and percentage changes to zero.

3.9.2 Span Calibration Scroll

Three simulated load calibration options are available: R-Cal, Test Weights and Test Chains. Test Weights or Test Chains require additional hardware and handling equipment.

The system allows the operator to select which one of the three methods is to be used for routine calibration. The selection is made in Main Menu 2, CAL DATA Scroll 1.

1. Auto Span
 - A. Starting an R-Cal Calibration

Press the SPAN CAL soft key. The following screen appears.

```
- AUTO SPAN R Cal -  
Run belt empty, then  
press START.  
START  EXIT  MANUAL
```

Pressing the EXIT soft key or MENU control key returns the screen to Main Menu 1.

Press START to initiate R-Cal span calibration. There is no totalization for three seconds until the weight signal has stabilized. Go to Step D below.

- B. Starting a Chain Calibration

Stop the conveyor belt.

Apply chains on conveyor belt.

Press SPAN CAL soft key. The following screen appears.

```
- AUTO SPAN Chain -  
Press START to begin  
chain calibration.  
START  EXIT  MANUAL
```

Password: Operator

Press **START** to disengage the Master Tons counter. The following screen appears.

```
- AUTO SPAN Chain -  
Apply chain, then  
press START.  
START  EXIT  MANUAL
```

Password: Operator

Pressing the EXIT soft key or MENU control key returns the screen to Main Menu 1.

When START is pressed, the following screen appears.

```
- AUTO SPAN Chain -  
Run belt, then  
press START.  
START  EXIT
```

Restart conveyor belt and insure chain placement is proper.

Press START.

Go to Step D below.

C. Starting a Test Weights Calibration

Stop the conveyor belt if necessary to apply test weights.

Press the SPAN CAL soft key. The following screen appears.

```
- AUTO SPAN Weights-  
Press START to begin  
weight calibration.  
START  EXIT  MANUAL
```

Password: Operator

Press **START** to disengage the Master Tons counter. The following screen appears.

```
- AUTO SPAN Weights-  
Apply weights, then  
press START.  
START  EXIT  MANUAL
```

Password: Operator

If the "LOAD WTS" output has been selected in the I/O Definition Scroll, test weights are automatically loaded after START is pressed. Wait for test weights to be loaded before proceeding. The message displayed will be "Press START to load test weights".

Pressing EXIT returns the screen to Main Menu 1.

Apply test weights.

When START is pressed, the following screen appears.

```
- AUTO SPAN Weights-  
Run belt, then  
press START.  
START  EXIT
```

Password: Operator

Restart the conveyor belt if it is not running and press START.

Go to Step D below.

D. Executing the Span Calibration

Whichever method has been used to start automatic span calibration, after START is pressed, the following screen is displayed.

NOTE: Entry point when REPEAT is pressed (see below).

```
AUTO SPANNING  
Time remaining 0000  
Rate 000.0 Tph  
Tot 000000 Tons
```

During Auto Span, the resolution of the total is ten times higher than normal. The time remaining shown in Line 2 is calculated upon the current speed, and it is based on the test duration. If the belt is stopped during the test, a message is displayed indicating the procedure has been suspended. No action is required from the operator at this stage, just wait until the test is completed.

E. Material Factor

This part of the procedure is only executed if a material calibration is done before, and the current simulated load method has no material factor installed.

NOTE: If a calibration with material has not been run before, or a manual span entry is done, or this is not the first time the current simulated method is used, this section does not apply. Go to Step F below.

It is very important to understand that when this procedure is executed, the system does not alter the span. The span is assumed to be correct because it was obtained from a test with material. The system acquires the Material Factor for the current calibration method instead. This means the integrator knows in the future how to use this method for correctly changing the system's span.

```
AUTO SPAN COMPLETE
Error +/-00.00 %
Unfactored Calcon
EXIT FACTOR REPEAT
```

The word "COMPLETE" is flashing. If EXIT is pressed, the system acknowledges the Material Factor is not used. The effect of this is the system does not ask for a material factor any more for this calibration method until a manual span entry is done. By pressing EXIT the operator tells the system that material factors is not desired, but wants to use the test results for changing the span number. After EXIT is pressed, go to Step F below. If REPEAT is pressed go to Step D above.

If FACTOR is pressed, the following screen is displayed.

```
R-CAL Matl FACTOR
New factor: 000.00 %
Change factor?
YES      NO      ADV
```

Can be R-CAL or WTS or CHAINS

ADV advances to Old factor and again to New factor. If NO is pressed, the Material Factor is set to 1.00 (see above), then go to Step F below.

If YES is pressed, the following screen is displayed.

```
R-CAL Matl FACTOR
Old factor: 00.00 %
New factor: 00.00 %
RUN MENU REPEAT
```

Can be R-CAL or WTS or CHAINS

The REPEAT key returns the operator to Step D above. RUN and MENU can be used for ending the procedure. After this point is reached, the system does not proceed to the next section.

F. Recording New Span

The system calculates the new span based on the result of the test performed with the simulated method.

```
AUTO SPAN COMPLETE
Error +/-00.00 %
Change span?
YES      NO      ADV
```

The word "COMPLETE" is flashing. Pressing ADV advances to Accumulated Weight, Cal Con, Material Factor and back to Error %. If the Material Factor is INVALID (never acquired before), it is not displayed.

If YES is pressed, the following screen is displayed.

```
SPAN # CHANGED
Old span # 000000
New span # 000000
RUN   REPEAT  ADV
```

ADV changes from Error % to Accumulated Weight, Calcon, Old Span, Material Factor (only if not INVALID). REPEAT moves back to Step D above and calibration restarts.

If NO is pressed, the following screen is displayed.

```
SPAN UNCHANGED
Old span # 000000
New span # 000000
RUN   REPEAT  ADV
```

ADV changes from Error % to Accumulated Weight, Calcon, Old Span, and Material Factor.

REPEAT moves back to Step D above and calibration restarts. Please note the Old span and New span are shown equally. This is because no change to the span has been done.

G. Ending an Auto Span Procedure with Chains or Test Weights

In case of auto-span with chains or weights, after RUN is pressed, the following screen is displayed.

```
Remove chains (or weights)
before returning to
normal operation!!
RUN   MENU
```

Pressing RUN resumes totalization and moves to the RUN Scroll.

H. Ending an Auto Span Procedure with R-Cal

In case of auto-span with R-Cal, after RUN is pressed, the R-Cal relay is deenergized and the display is locked for three seconds.

2. Manual Span

If the span constant is known, the manual span procedure allows the operator to make a direct a change of span.

```
-   MANUAL SPAN   -
Rate   000.0 Tph
Span # 0000000
ENTER EXIT  RUN
```

Password: Operator

Default: 300000
Min: 222223
Max: 20000002

The EXIT key returns the operator to Main Menu 1.

It is very important to note that entering the Manual Span sets the material factors to INVALID (if any). This means that the automatic span tests need to be run again after a manual span entry has been performed, in order to acquire the material factors again.

3.9.3 Material Span Calibration

Material span calibration is a machine directed procedure for calibrating the belt scale using actual material.

Preweighed or postweighed material, having been weighed to a known accuracy on a static scale, passes across the belt scale. This procedure automatically adjusts the integrator span and factors all simulated load test Cal Cons if the operator prefers they be factored.

1. Material Calibration Procedure

A. Starting the Test

Press MAT'L CAL soft key and DOWN ARROW. The following screen appears.

```
MAT'L CALIBRATION
Run belt empty, then
press START.
START  MENU
```

The operator must run the belt for at least one minute or one belt revolution before proceeding. After START is pressed, the master weight totalizer is disengaged.

When START is pressed, the following screen appears.

```
Run quantity of
material over scale.

CONTINUE
```

Press CONTINUE to go to the next scroll and follow the test procedure.

B. Running the Test with Material

```
00000.0 Tons
0000.0 Tph
Press DONE to end
DONE  ABORT
```

During the material calibrate procedure, the resolution of total tons counted is ten times higher than normal.

Wait until all material has passed over the scale, then press DONE. Pressing ABORT forces the program back to the top of the MAT'L CAL Scroll.

C. Entering the Reference Weight

At the end of the test, the system asks the operator whether the (actual) weight of the material is already known.

```
0000.00 Tons
Ref. weight known?

YES      NO
```

Press NO if the reference (actual) weight will not be known for some time and the conveying systems need to be returned to run. If NO is pressed, the RUN screen appears. MAT'L will be flashing to remind the operator that the material test is incomplete.

Press MAT'L when the reference weight is known and enter in the following screen.

If YES was answered before, or if the MAT'L key had been pressed after NO, the following screen appears.

```
00000.00 Tons
Enter reference
weight 00.0 Tons
ENTER      ABORT
```

The operator has to enter the actual material weight in the same weight units as the integrator is setup for. Example: Convert pounds to the nearest hundredth (0.01) of a ton and enter if the integrator is set up for tenths (0.1) of a ton increments. Material calibration is running at ten times normal.

After the material weight is entered, press ENTER to confirm.

If ABORT is pressed, the information acquired during the test is lost and the system returns to Main Menu 1 screen.

D. Updating the Span Constant

After the amount of material has been entered, the following screen is displayed.

```

MAT'L CAL. COMPLETE
Error 000.00 %
Change span?
YES      NO      ADV

```

The word "COMPLETE" is flashing. Pressing ADV changes from Error % to Actual Difference of Total. Pressing NO moves to "Add reference weight to total".

E. Acquiring the Material Factors

If YES was pressed, the following screen is displayed confirming the new span constant was installed. At this point, the scale is calibrated to the actual material test.

```

SPAN # CHANGED
New span # 000000
Old span # 000000
RUN      MENU  FACTOR

```

If FACTOR is pressed, the following screen is displayed.

```

MAT'L CALIBRATION
Automatic correction
to Material Factors
R-CAL  WTS  CHAIN

```

Of the three simulated load calibration methods, only the ones that have been already used are shown. It is not possible to calculate a material factor if a simulated test was not run before the material test. If none of the three was done, the FACTOR soft key in the previous scroll is not displayed.

If R-CAL or WTS or CHAIN is pressed:

```

R-CAL Matl FACTOR
New factor 000.00 %
Change factor?
YES      NO      ADV

```

Can be R-CAL or WTS or CHAINS

Pressing ADV advances to the Old factor and again to the New factor. YES goes to the next scroll. NO goes back to Step E above. Press YES if this specific simulated method of calibration has already been used and the related material factor will be recorded. By doing this, the system is able to execute accurate calibrations in the future with this simulated method. Press NO if the acquired material factor is not desired. If YES is pressed, the following screen is displayed.

```
R-CAL Mat1 FACTOR
Old factor: 00.00 %
New factor: 00.00 %
RUN MENU FACTOR
```

Can be R-CAL or WTS or CHAINS

The FACTOR key repeats for all simulated test previously run. If RUN or MENU is pressed, the following screen is displayed.

F. Adding the Reference Weight to Total

```
MAT'L CALIBRATION
Add reference
weight to totals
YES NO
```

If YES is pressed, the amount of material used for the test is added to the master, reset and operator's totals. If the answer NO is selected, the information is lost.

NOTE: Moisture compensation is inhibited during material calibration. This is done to make the check of the totalized quantity easier. The static scale provides the weight of the material including moisture. The weight of the water is removed immediately before adding to total at the end of the procedure, so that the Master, Reset and Operator's totals are still correct.

3.10 PERMANENT SCROLL RECORD - SETUP SCROLLS

MAIN MENU 1

ZERO SCROLL

Zero # _____

SPAN SCROLL

Span # _____

MAIN MENU 2

DISPLAY SCROLL

1. Measure Units _____

2. Totalization Units _____

3. Length Units _____

4. Rate Units _____

5. Loadcell Units _____

6. Language _____

9. Run Display, Line 3 _____

10. Damping Display Rate _____

11. Damping Display Load _____

12. Damping Display Speed _____

SCALE DATA SCROLL

1. Max. Scale Capacity _____

2. Scale Divisions _____

3. Belt Scale Code # _____

3A. Pivot to Load Cell _____

3B. Number of Weigh Idlers _____

3C. Pivot to 1st Idler _____

3D. Pivot to 2nd Idler _____

3E. Pivot to 3rd Idler _____

3F. Pivot to 4th Idler _____

- 3G. Pivot to 5th Idler _____
- 3H. Pivot to 6th Idler _____
- 3I. Pivot to Test Weight Height _____
- 3L. Pivot to Test Weight Length _____
- 3M. Pivot to Carriage Height _____
- 3N. Roll to Carriage Height _____
- 3O. Number of Load Cells _____
- 4. Idler Spacing _____
- 5. Conveyor's Angle Degrees _____
- 6. Load Cell Capacity _____
- 7. Load Cell Sensitivity _____
- 8A. Load Cell #1 Resistance _____
- 8B. Load Cell #2 Resistance _____
- 8C. Load Cell #3 Resistance _____
- 8D. Load Cell #4 Resistance _____
- 8E. Load Cell #5 Resistance _____
- 8F. Load Cell #6 Resistance _____
- 9. Speed Input _____
- 10. Zero Dead Band Range _____
- 11. Weights & Measures Mode _____

CALIBRATION DATA SCROLL

- 1. Calibration Mode _____
- 2. R-Cal: Resistance (Ohms) _____
- 3. R-Cal: Cal-Constant _____
- 4. Chain: Weight (Lbs/Ft) _____
- 5. Chain: Cal Constant _____
- 6. Total Test Weights (Lbs) _____
- 7. Weight: Cal-Constant _____

- 8. Calibration Interval Days

- 9. Calibration Date

- 10. R-Cal: Mat'l Factor

- Chain: Mat'l Factor

- Weight: Mat'l Factor

- 11. Test Duration Full Partial Manual
- Belt Length

- Number of Revolutions

- Test Time

- 12. Auto Zero Tracking Yes No
- 12A. Auto Zero Tracking Range _____ %
- 12B. Auto Zero Tracking Max. Dev. _____ %
- 13. Max. Speed Capacity

- 14. Number of Calib.

MAIN MENU 3

PROTECTION SCROLL

- 1. Protection Level None Ltd Prot

DIAGNOSTICS SCROLL

- 1. A/D Gross

- A/D Net

- 2. Weight on Load Cell

- 2A. Load Cell Output Zero

- 2B. Load Cell Output Span

- 3. Prescale

- Pulses/Minute

- 3A. Test Duration Total Pulses

- 3B. Test Duration Total Length

- 4. Service Password

- 5. Operator Password

- 6. Software Version _____
- 9. Board Type Slot #1 _____
- 10. Board Type Slot #2 _____
- 11. Board Type Slot #3 _____
- 12. Board Type Slot #4 _____
- 13. Board Type Slot #5 _____
- 14. Board Type Slot #6 _____

MAIN MENU 4

I/O DEFINE SCROLL

- 1. Current Output #1 Define _____
- Current Output #2 Define _____
- 1A. Current Output #1 Range _____ mA
- Current Output #2 Range _____ mA
- 1B. Current Output #1 Delay _____ sec L
- Current Output #2 Delay _____ sec L
- 1C. Current Output #1 Damping _____ sec
- Current Output #2 Damping _____ sec
- 2. Analog Input #1 Definition _____
- 2A. Moisture Input Calibrate _____ % V
- 2B. Moisture Input Calibrate _____ % V
- 3. Analog Input #2 Definition _____
- 3A. Conveyor Low Position _____ Degrees
- 3B. Conveyor High Position _____ Degrees
- 4. Digital Input Define _____
- Physical Input Status
- External Alarm #1 _____ /
- External Alarm #2 _____ /
- External Alarm #3 _____ /
- Print _____ /

Belt Running	/
Reset Total	/
Reset Alarm	/
Auto Zero	/
Clip Detector	/
Calibration Select 1	/
Calibration Select 2	/
Calibration Select 3	/
Calibration Select 4	/
Calibration Select 5	/
Calibration Select 6	/
Calibration Select 7	/
Calibration Select 8	/
Calibration Select 9	/
Calibration Select 10	/
5. Digital Output Define	Physical Output Status
Alarm	/
Shutdown	/
Ready	/
High Load	/
Low Load	/
High Rate	/
Low Rate	/
High Speed	/
Low Speed	/
Print Ready	/
Totalizer	/
Batch Preset	/

Batch End	_____
	/
Load WTS (Weights)	_____
	/
Dev. Alarms	_____
	/
Out of Range	_____
	/
6. Remote Counter Division	_____
7. Remote Counter Pulse Width	_____
10. Clip Detector Mode	_____
10A. Clip Detector Length	_____

ALARMS SCROLL

1. Rate Alarm	<input type="checkbox"/> Yes	<input type="checkbox"/> No	
1A. Low Rate Set		%	sec
1B. High Rate Set		%	sec
2. Load Alarm	<input type="checkbox"/> Yes	<input type="checkbox"/> No	
2A. Low Load Set		%	sec
2B. High Load Set		%	sec
3. Speed Alarm	<input type="checkbox"/> Yes	<input type="checkbox"/> No	
3A. Low Speed Set		%	sec
3B. High Speed Set		%	sec
4. Low Speed Set		%	sec
4A. Belt Slip Set		%	sec
5. Alarm Set As	<input type="checkbox"/> Alarm	<input type="checkbox"/> Shutdown	<input type="checkbox"/> None
#1 Clock Fail	_____		
#2 Load Cell Fail	_____		
#3 RAM Fail	_____		
#4 ROM Fail	_____		
#5 Speed Sensor	_____		
#6 High Load	_____		
#7 Low Load	_____		
#8 High Rate	_____		

- #9 Low Rate _____
- #10 High Speed _____
- #11 Low Speed _____
- #12 Warm Start _____
- #13 Cold Start _____
- #14 P.D. Calibrate _____
- #15 Calibrate Time _____
- #16 Ext. Alarm #1 _____
- #17 Ext. Alarm #2 _____
- #18 Ext. Alarm #3 _____
- #19 Overflow Totalizer _____
- #20 AZT Limit _____
- #21 Batch Deviation _____
- #22 BCD Error _____
- #23 thru 28 HW Conf. Change _____
- #29 Math Error _____
- #30 Printer Error _____
- #31 COMM Error _____
- #32 Allen-Bradley RIO Error _____
- #33 PROFIBUS-DP Error _____

LOAD OUT SCROLL

- 1. Preset Weight _____
- 2. Pre Act Correction _____
- 2A. Pre Act Value _____
- 2B. Pre Act Range _____
- 2C. Pre Act Length _____
- 3. Start Delay _____
- 4. Coasting Time _____
- 5. Batch Deviation _____

- | | | |
|--------------------------|-----------|-----------|
| 6. Print Batch | _____ | |
| 7. Position Batch Num. | X = _____ | Y = _____ |
| 8. Position Batch Quant. | X = _____ | Y = _____ |
| 9. Position Batch Total | X = _____ | Y = _____ |

MAIN MENU 5

COMM A SCROLL

- | | |
|-------------------------|-------|
| 1. Baud Rate Port #1 | _____ |
| 2. Set Parity Port #1 | _____ |
| 3. Stop Bits Port #1 | _____ |
| 4. Word Length Port #1 | _____ |
| 5. Protocol Port #1 | _____ |
| 5A. Clear to Send #1 | _____ |
| 6. Address Port #1 | _____ |
| 7. Access Prot Port #1 | _____ |
| 8. Baud Rate Port #2 | _____ |
| 9. Set Parity Port #2 | _____ |
| 10. Stop Bits Port #2 | _____ |
| 11. Word Length Port #2 | _____ |
| 12. Protocol Port #2 | _____ |
| 12A. Clear to Send #2 | _____ |
| 13. Address Port #2 | _____ |
| 14. Access Prot Port #2 | _____ |

PRINT SCROLL

- | | |
|----------------------|-------|
| 1. Handshaking | _____ |
| 2. End of Line | _____ |
| 3. Delay End of Line | _____ |
| 4. Form Feed | _____ |
| 5. Print Interval | _____ |
| 6. Print Time #1 | _____ |

- 7. Print Alarms _____
- 8. Totals Report Format _____
- 9A. Number of Strings _____
- 9B. Contents String #1 _____
- 9C. Position String Number #1 _____
- 9D. Contents String #2 _____
- 9E. Position String #2 _____
- 9F. Contents String #3 _____
- 9G. Position String #3 _____
- 9H. Position Oper. Total _____
- 9I. Position Reset Total _____
- 9J. Position Master Total _____
- 9K. Position Date _____
- 9L. Position Time _____
- 9M. Position Rate _____
- 9N. Position Avg. Rate _____
- 9P. Position Running _____

MAIN MENU 6

LINEARIZATION SCROLL

Linearization

Yes

No

LOAD

FACTOR

LIN Factor #1

LIN Factor #2

LIN Factor #3

LIN Factor #4

LIN Factor #5

3.11 PERMANENT FIELD RECORD

Conveyor Number _____

Date _____

1. Scale Capacity _____ (Tons Per Hour)
2. Belt Scale Code Number _____
3. Belt Scale Weighbridge Dimensions
 - a. Pivot to Load Cell Distance _____ (Inches)
 - b. Number of Weigh Idlers _____
 - c. Pivot to Weight Idler Distance (Inches)
 - 1st _____ 4th _____
 - 2nd _____ 5th _____
 - 3rd _____ 6th _____
 - d. Pivot to Test Weight Height _____ (Inches)
 - e. Pivot to Test Weight Length _____ (Inches)
 - f. Pivot to Carriage Height _____ (Inches)
 - g. Carry Roll to Carriage Height _____ (Inches)
4. Number of Load Cells _____
5. Idler Spacing _____ (Inches)
6. Conveyor's Angle of Incline _____ (Degrees)
7. Load Cell Capacity _____ (Pounds)
8. Conveyor Belt Length _____ (Feet)

3.12 CALIBRATION REPORT

CALIBRATION REPORT - PERMANENT RECORD Conveyor _____

Date				
By				
Scale Capacity				
Belt Length				
Test Length				
Test Time				
Calib. Constant				
R-Cal				
Static				
Chain				
Calibration Mode				
Zero - As Found				
- As Left				
Span - As Found				
- As Left				

CHAPTER 4.0 MAINTENANCE

4.1 SERVICE AND REPAIR

The maintenance information in this manual should meet your service needs. If problems occur that require technical assistance, please call (763)783-2700.

Ramsey has a repair center located at our plant in Minneapolis, Minnesota. Contact our Repair Representative at (763)783-2774 for assistance. To expedite your service request, please have your machine model and serial number available.

When returning parts for repair, please use the Return Material Authorization form located in the Replacement parts section of this manual.

4.2 FREQUENT CHECKPOINTS

The Micro-Tech 2101 Integrator is a solid-state device, and as such, should require very little maintenance. The front panel can be wiped clean with a damp cloth, and if necessary, a mild detergent (never use abrasive cleaners, especially on the display window). As a preventative measure, check that all wires, plugs, and integrated circuits are tight in their connectors. Also keep the enclosure door tightly closed to prevent dirt infiltration.

More often than not, a quick visual inspection leads to the source of trouble. If a problem does develop, check the following before proceeding to more specific troubleshooting procedures.

1. Check Power
 - A. Check that the two (2) Line Voltage Selector Switches are set to the correct line voltage (see Section 2.4.1).
 - B. Check the fuses.
 - C. Check that the power switch is ON and that power is supplied to the unit.
2. Check Connections
 - A. Check that all terminations are secure.
 - B. Check that the Display Module and Keyboard connectors are firmly seated in their connectors.
 - C. Check that the Remote Counter and optional input/output modules are secure in their sockets.
 - D. Check that all Jumpers are in their correct position.

4.3 TROUBLESHOOTING

This unit has built-in troubleshooting capabilities. A number of possible problems are automatically detected and screen messages are displayed. Also refer to the Diagnostics Test Scrolls in Main Menu 3.

4.3.1 Alarm Message

The ALARM message is assigned to the right hand soft key when an alarm is pending. The ALARM message and its LED flash at the same time.

The following screen is displayed when the right hand soft key is pressed.

```
ALARM      NEW
xxxxxxxxxxxxxxxxxxxxxxxxxxxx
MM-DD-YYYY  HH:MM
RESET      NEXT
```

The keyword "NEW" indicates an alarm that has not yet been acknowledged. When the operator presses the **RESET** key to clear the alarm, the alarm disappears only if the reason that caused the alarm to occur does not exist any more. If the alarm is still pending, the keyword "ACK" is displayed instead of "NEW".

The third line shows the date and time only if the optional COMM board is installed.

The **NEXT** key is used to scroll between the pending alarms. The string "xxxxxxxxxxxxxxxxxxxx" represents one of the following alarm conditions.

4.3.2 Alarms List

1. Clock Fail

The system has detected a failure on the clock calendar circuit. This alarm only occurs if the optional COMM board is installed.

- Check the COMM board to see if it is properly inserted.
- Replace the COMM board.

2. Load Cell Fail

The system has detected an error on the load cell signal.

- Check the load cell connections.
- Check the load cell(s).

3. RAM Fail

The system has detected an error on the RAM checksum during the internal periodical test. The RAM (Random Access Memory) is used to store variables and set up data.

- Replace the CPU board.

4. ROM Fail

The system has detected an error on the ROM checksum during the internal periodical test. The ROM (Read Only Memory) is used to store the program.

- Replace the CPU board.

5. Speed Sensor

This message can only appear if the DUAL speed mode is selected. The system has detected a difference between the speeds of the two sensors, higher than the one specified in the ALARM menu.

- Check the speed sensors.

6. High Load

The belt load has been detected to be higher than the maximum belt loading entered in the ALARM SET UP MENU.

7. Low Load

The belt load has been detected to be lower than the minimum belt loading entered in the ALARM SET UP MENU.

8. High Rate

The rate has been detected to be higher than the maximum rate entered in the ALARM SET UP MENU.

9. Low Rate

The rate has been detected to be lower than the minimum rate entered in the ALARM SET UP MENU.

10. High Speed

The speed has been detected to be higher than the maximum speed entered in the ALARM SET UP MENU.

11. Low Speed

The rate has been detected to be lower than the minimum speed entered in the ALARM SET UP MENU.

12. Warm Start

The system has detected a power loss condition, or power was removed for an undefined period of time.

13. Cold Start

The system has detected the loss of the set up data after power was removed. The instrument needs to be set up and calibrated.

- Replace either the mother board or the battery.

NOTE: The message COLD START never appears on the screen. This is because a Cold Start forces a start up procedure to be executed, and the alarm itself is cleared after the set up is completed. However, the alarm LED and the digital output will be showing an alarm during the initial set up procedure.

14. P.D. Calibrat

When the system is powered off while a calibration sequence is in progress, the scale may not be properly calibrated.

- Check calibration.

15. Calib Time

If a calibration check time period is entered and the time expires, this alarm occurs. The purpose is to remind the operator that the calibration has not been checked for a considerably long period of time.

- Check calibration.

16. Ext. Alarm 1

Digital inputs can be programmed to detect external alarm conditions such as emergency switches, max level switches or other. This alarm is associated to the external alarm #1.

- Check external alarm #1.

17. Ext. Alarm 2

- Check external alarm #2.

18. Ext. Alarm 3

- Check external alarm #3.

19. Overflow Tot.

This message indicates the output pulse generator for the remote mechanical totalizer has reached an overflow condition. The rate may be too high or the pulse divider has been set too small.

- Check the rate.
- Check and eventually increase the pulse divider.

This message is also displayed if the Master Total rolls over.

20. AZT Limit

The Auto Zero Tracking function has reached the maximum limit of tare that is allowed to be automatically cleared. The scale may be dirty or misaligned.

- Check and clean the scale.
- Perform an autozero.

21. Batch Deviat.

This alarm is only visible if the optional Load Out board is installed. It is generated when a batch is run and the error detected at the end of the batch is higher than specified.

- Check the parameters of the load out.
- Adjust the preact value.

22. BCD Error

This message is only displayed if the optional BCD output board is installed. If the variable to be converted in the BCD format has more than 4 digits, the alarm is generated.

- Check the size of variables and the BCD data setup.

23 through 28. HW Conf. Changed

When a new board is installed or an old board removed, this message appears. Refer to Appendix A/4, Section 4.3.2, number 7 of this document (normal power on).

29. Math Error

A divide by zero or overflow error is encountered during internal calculations. This message indicates some abnormal dimensional parameter is entered in setup.

- Check setup data.

30. Printer Error

This message is displayed if the system has data to print and the printer is disconnected or the paper feed is empty.

31. Communication Error

This message is only displayed if the optional COMM board is installed. It indicates that a time out or handshake error is detected during a data transfer on the COMM line.

- Check the COMM line connections.
- Check the COMM line setup data.

32. Allen-Bradley Remote I/O COMM Error

This message is displayed if communication is interrupted. The green LED on the A-B R/I/O board will be flashing. The alarm does not come on if communication has never started.

33. PROFIBUS-DP COMM Error

This message is only displayed if the optional PROFIBUS board is installed. The following two conditions activate the alarm.

- a. If the Siemens SPC3 controller installed on the PROFIBUS interface board does not recognize any successful data transfer within the watch dog timer interval.
- b. If the received data contains errors (value overlaps limits, register number does not exist, group number does not exist).

4.3.3 Micro-Tech 2000 Cold Start

It may be necessary to cold start the Micro-Tech 2000 in the event the software becomes corrupted. You have the option of installing the factory default constants or simply returning the Micro-Tech 2000 to its previous running state.

There are two methods of forcing a cold start via the front panel: in Run mode or from the DIAGNOSTIC SCROLL.

1. To force a cold start from RUN mode:

Press and hold in at the same time the LEFT HAND ARROW key and the CLEAR key until the following screen appears.

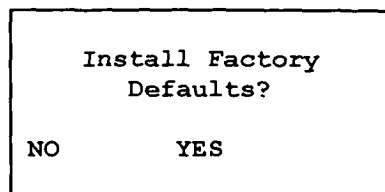

Pressing NO returns the Micro-Tech 2000 to the RUN mode.

If YES is pressed, the following screen appears.

```
- MEMORY ERASED -  
Choose the language  
key to continue to  
ESP                USA
```

When the above screen appears, all field entry data has been replaced by the factory default constants. Proceed to Initial Setup Procedure, Section 2.5.2.

NOTE: If the software corruption was catastrophic and the memory would not erase in the above step, do the following:

Press and hold in the LEFT HAND ARROW key and the CLEAR key. While holding in both keys, cycle line power. In the event the MEMORY ERASED screen does not appear, consult the Factory.

2. To force a cold start from the DIAGNOSTIC SCROLL:

Press MENU until MAIN MENU 3 appears, then press the DIAG soft key. Press the down arrow key until the following screen is displayed.

```
-DIAGNOST.SCROLL 15-  
Force cold start  
  
ENTER
```

When you press ENTER, the following screen is displayed:

```
ATTENTION  
ARE YOU SURE?  
  
YES    RETURN
```

Pressing RETURN will return to DIAGNOSTIC SCROLL 15.

Pressing YES displays the following screen:

```
Install Factory  
Defaults  
  
YES    RETURN
```

Pressing RETURN will return to DIAGNOSTIC SCROLL 15.

Pressing YES clears all field entry data and installs factory default constants. The following screen is displayed:

```
- MEMORY ERASED -  
Choose the language  
key to continue to  
ESP          USA
```

Proceed to Initial Setup Procedure, Section 2.5.2.

4.3.4 Internal Test Procedure

Pressing **START** on the screen (located in Main Menu 3) enacts a self-test of the internal microprocessor.

```
- TEST SCROLL 2 -  
Internal test of  
microprocessor.  
START
```

Password: Service

After **START** is pressed, the following screens are displayed in sequence.

```
- TEST SCROLL 2A -  
Testing ROM  
Test PASSED
```

```
- TEST SCROLL 2B -  
Testing RAM  
Test PASSED
```

```
- TEST SCROLL 2C -  
Testing E2PROM  
Test PASSED
```

Only if Audit Trail is installed

The message "Test PASSED" is displayed if the test runs correctly. If something wrong is detected, then the message "Test FAILED" is displayed, and the soft key **CONTINUE** is shown. The operator has to press the key to go on to the next test.

If the internal test has failed, call Ramsey's Customer Service Department.

4.3.5 Load Cell Excitation and Signal Voltage

1. Measure excitation voltage across terminal 21 negative and 20 positive in the scale junction box. This should be 10 VDC +/- 5%.

2. If the excitation voltage is incorrect, then measure the excitation voltage in the Integrator across terminal TB9-9 negative and TB9-10 positive. This should be 10 VDC +/- 5%.
3. Measure DC millivolt signal voltage across terminal 22 positive and 23 negative in the scale junction box. This should be within 0-30 millivolts DC (3 mV/V load cell).
4. Measure DC millivolt signal voltage across terminal TB9-12 positive and TB9-11 negative in the Integrator. This should be the same as Step 3 above.
5. The millivolt output is in direct relation to weight applied. As weight is increased, output should increase.

4.3.6 Resetting Master Total Procedure

Steps required to reset master total or to reset remote counter overflow are given below.

A. If No Password is Installed

1. Select Main Menu 3.
2. Press **DIAG** soft key and scroll down to the Service Password screen.
3. Type in a password (Example: 123) and press **ENTER**.
4. Re-enter the password and press **ENTER**.
5. Select Main Menu 3.
6. Press **PROT** scroll and press **PROT** soft key.
7. Press the **NONE** soft key.
8. Type in password 7832500 and press **ENTER**. The protection level should be RAMSEY.
9. Press the **TOTAL** key on the touch panel. Scroll up or down if needed to reach the Master Total screen.
10. Press the **RESET** soft key and answer YES to Reset Master Total?
11. Select Main Menu 3. Press the **DIAG** soft key and scroll down to Service Password.
12. Press **ENTER** twice, erasing the password installed in Step 3.
13. Press the **RUN** key to return to normal operation.

B. If Password is Already Active

1. Select Main Menu 3.
2. Press the **PROT** scroll and press the **PROT** soft key.
3. Press the **NONE** soft key.
4. Type in password 7832500 and press **ENTER**. The protection level should be RAMSEY.
5. Press the **TOTAL** key on the touch panel. Scroll up or down if needed to reach the Master Total screen.

6. Press the **RESET** soft key and answer YES to Reset Master Total?
7. Select Main Menu 3.
8. Press the **PROT** scroll and choose the password level desired.

4.3.7 To Remove a Forgotten Password

1. Select Main Menu 3.
2. Press the **PROTECT** scroll and press the **PROT** soft key.
3. Press the **NONE** soft key.
4. Type in password 7832500 and press **ENTER**. The protection level should be **RAMSEY**.
5. Press **NONE**.
6. Select Main Menu 3.
7. Press the **DIAG** soft key and scroll down to Service Password.
8. Press **ENTER** twice. The display should respond with New Password Acquired.
9. Scroll down to Operator Password. Press **ENTER** twice. The display should respond with New Password Acquired.
10. Select Main Menu 3. The **PROT** soft key should not appear, indicating all passwords have been erased. If **PROT** should appear, repeat Steps 1 through 9.
11. See Appendix A/4, Section 4.3 for entering new passwords.

4.4 LITHIUM BATTERY REPLACEMENT

The Micro-Tech volatile memory backup battery can be replaced without any special tools. See Figure 4-1 for battery location on the mother board.

WARNING

DANGER OF EXPLOSION IF BATTERY IS INCORRECTLY REPLACED.

Replace only with same or equivalent type recommended by Ramsey. Dispose of used battery according to manufactures instruction on battery or return to Ramsey. See Section 4.5 below.

1. Record all configuration, setup and calibration data before removing battery. All information is lost when the battery is removed.
2. Turn the Micro-Tech power off at the mains.
3. Remove the battery from its compression socket.
4. Observe the polarity markings on the battery socket base before inserting the new battery. The lithium battery is .3 V, 1.2 AH, 2/3 A., Ramsey part number 037188.
5. Insert battery.
6. Restore power to the Micro-Tech.
7. Cold start the Micro-Tech. See cold start procedure, Section 4.3.3.

8. Re-enter all data recorded in Step 1.

4.5 DISPOSAL OF HAZARDOUS WASTE

Disposal of Lithium batteries and soldered printed circuit boards should be in accordance with your local Hazardous Waste Policy.

As an alternative, you may return product supplied by Ramsey, freight prepaid for disposal. Contact our repair department for a Return Authorization Number before shipping any product for disposal.

4.6 CLEANING INSTRUCTIONS

The Micro-Tech 2101 Integrator is a solid-state device, and as such, should require very little maintenance. The front panel can be wiped clean with a damp cloth, and if necessary, a mild detergent (never use abrasive cleaners, especially on the display window). As a preventative measure, check that all wires, plugs, and integrated circuits are tight in their connectors. Also keep the enclosure door tightly closed to prevent dirt infiltration.

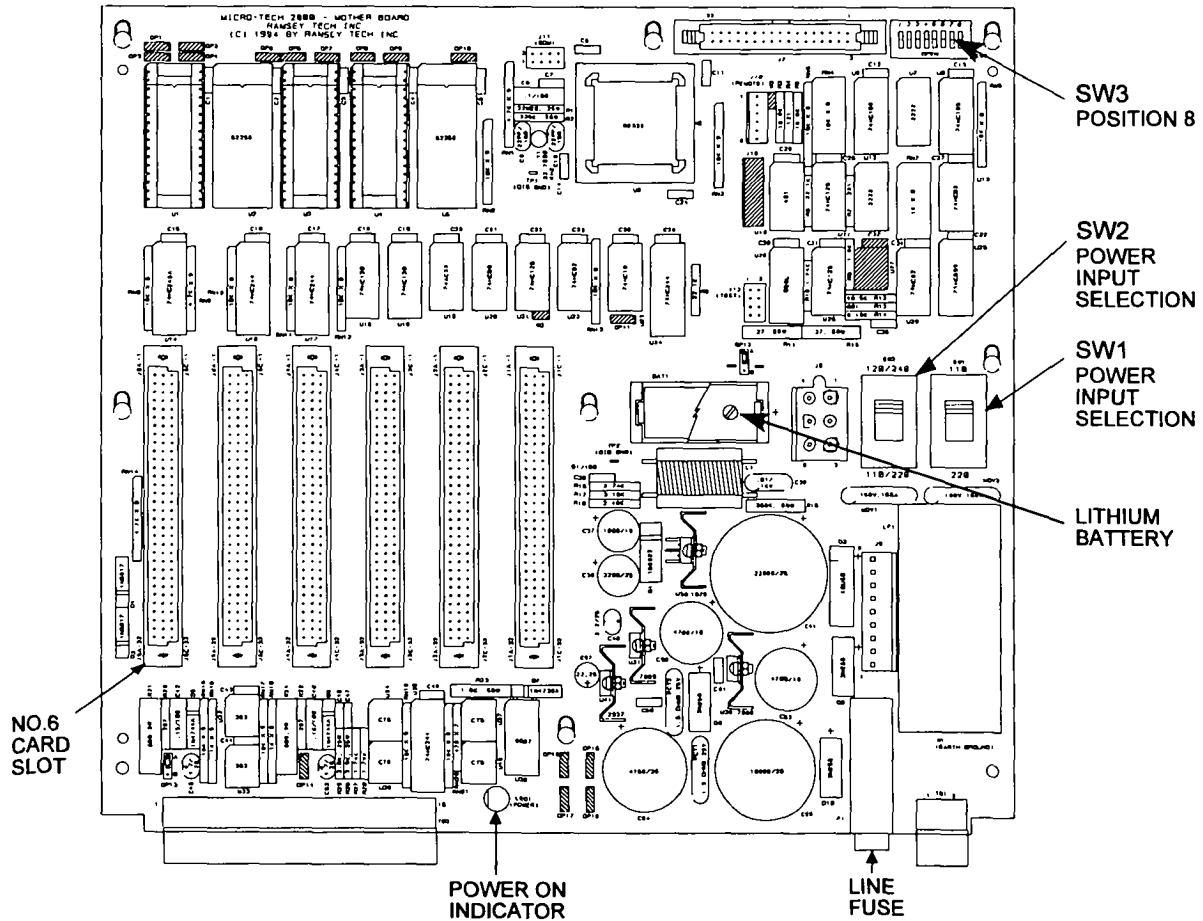

A00926b

MODEL 2101 MOTHER BOARD
FIGURE 4-1

CHAPTER 5.0 REPLACEMENT PARTS

5.1 GENERAL

This chapter gives information on how to order replacement parts for your Micro-Tech 2101 Integrator.

5.2 ORDER INFORMATION

For faster service when ordering parts, fax or telephone Ramsey Parts Department.

The recommended procedure for ordering parts is as follows:

1. Determine the broken or faulty part(s).
2. Locate the part(s) in the parts list given.
3. Find the part number(s) for the item(s) needed and determine the quantity you require.
4. Write or telephone:

Ramsey Technology, Inc.
Customer Service Department
501 90th Ave. NW
Minneapolis, MN 55433
Fax: (763)783-2525

Customers A through I - (763)783-2775
Customers J through Z - (763)783-2773
Repair and Returns - (763)783-2774

Normal Customer Service hours are 8:00 a.m. to 4:30 p.m., Central Time.

5. With your order, list the following information:

Integrator model and serial number
Purchase order number
Date required
Method of shipment preferred
List of parts, including part number, description and quantity

Your parts order will be handled as expeditiously as possible.

5.2.1 Return Material Authorization



RMA No. R- _____

(This RMA number must be marked on all paperwork and on the outside of the package.)

Req'd By: _____

Return, Freight Prepaid to:

Date: _____

Ramsey Technology, Inc.
501 90th Avenue N.W.
Minneapolis, MN 55433

Customer Contact: _____

Telephone: 763 / 783-2774
Telefax: 763 / 783-2525

Phone No.: () _____

Bill to Customer #: _____
Area Code

Ship to #: _____

Returned From: _____

Return To: _____

Description of Material Being Returned:

Describe Equipment Malfunction or Defect. If any: symptoms:

Minimum Charge:

Informed Customer of \$50.00 Inspection Charge Per Item

Service Requested:

Repair & Return Estimate Required

P. O. No.: _____

Original P. O. or RTI Order No.: _____

Return for Credit

Warranty Repair or Replacement

Original P. O. No.: _____

Serial No.: _____

Original Order/Job No.: _____

Return Warranty/Exchange Unit

Shipped on RTI Order No.: _____

Other: _____

Disposition/Comments: (For RTI internal use only)

5.2.2 Parts List

<u>EQUIPMENT</u>	<u>PART NUMBER</u>
<u>MICRO-TECH™ 2000 Model 2101 Integrator</u>	
Chassis Assembly, Panel Mount	047649
Chassis Assembly, Field Mount	050101
PCBA, Mother Board	051320
PCBA, A/D Single Channel Plant	046409
PCBA, Analog Output (1 out)	049004
PCBA, Analog Output (2 in/2 out)	049003
PCBA, DIO (4 in/16 out)	046841
PCBA, DIO (16 in/4 out)	046844
PCBA, COMM "A" Select one only	046853
RS-232C	
RS-485, std. (point to point)	
RS-485, multi-drop	
20 mA (digital) current loop	
PCBA, LED Assembly	046847
PCBA, Display Assembly	046860
PCBA, Touch Panel Model 2101	047075
PCBA, Field Terminal Entry	047572
PCBA, Load Out DIO (4 in/16 out)	049475
PCBA, Load Out DIO (16 in/4 out)	049476
PCBA, Allen-Bradley RI/O	055517
PCBA, PROFIBUS-DP	056713
Fuse, Slo-Blo, .5 Amp (F1 220V) (Type T)	001366
Fuse, Slo-Blo, 1.0 Amp (F1 110V) (Type T)	002443
Fuse, Fast-Blo, 4.0 Amp (FT Board) (Type T)	037287
Prom, U1, MT-2000 Audit Trail	050500
Battery, Lithium, 3.0 V, 1.2 AH, 2/3 A.	037188
Transformer, Power	046863
Module, Power Input 180-240 VAC	047646
Module, Power Input 90-120 VAC	047575
Module, Power Input 10-32 VDC	048162
Module, Power Output 24-240 VAC	046814
Module, Power Output 5-60 VDC	046815

**APPENDIX A/1
RAMSEY WEIGHBRIDGE PHYSICAL PARAMETERS**

1.0 GENERAL

This appendix contains a listing of all weighbridges manufactured by Ramsey. Each weighbridge is assigned a code number to be entered during initial programming of the Integrator. This code number defines the selected weighbridge's default parameters and enables the Integrator to calculate span calibration constants (Cal-Con) for simulated calibration modes selected.

Weighbridge physical parameters can be altered by pressing the soft key **DETAIL** in Scale Data Scroll 3. Scroll down to the desired parameter and enter in the correct factor. Cal-Con's are calculated.

Weighbridges not manufactured by Ramsey can be defined by entering code number **0** and pressing **DETAIL** in Scale Data Scroll 3. Scroll down and enter the weighbridge parameters in scroll positions 3A through 8F.

Physical parameters and typical scale models are as follows:

SCALE DATA SCROLL POSITIONS	PARAMETER	
3		Belt Scale Code #
3A	(LA)	Pivot to Load Cell Distance
3B	(IDL)	No. of Weigh Idlers
3C	(LB1)	Pivot to 1st Idler Distance
3D	(LB2)	Pivot to 2nd Idler Distance
3E	(LB3)	Pivot to 3rd Idler Distance
3F	(LB4)	Pivot to 4th Idler Distance
3G	(LB5)	Pivot to 5th Idler Distance
3H	(LB6)	Pivot to 6th Idler Distance
3I	(LE)	Pivot to Test Weight Height
3L	(LC)	Pivot to Test Weight Length
3M	(LF)	Pivot to Carriage Height
3N	(LG)	Carry Roll to Carriage Height
3O		No. of Load Cells
4	(LD)	Idler Spacing
5		Conveyor's Angle Degrees
6		Load Cell Capacity
7		Load Cell Sensitivity mV/V
8A		Load Cell No.1 Resistance ohms
8B		Load Cell No.2 Resistance ohms
8C		Load Cell No.3 Resistance ohms
8D		Load Cell No.4 Resistance ohms
8E		Load Cell No.5 Resistance ohms
8F		Load Cell No.6 Resistance ohms

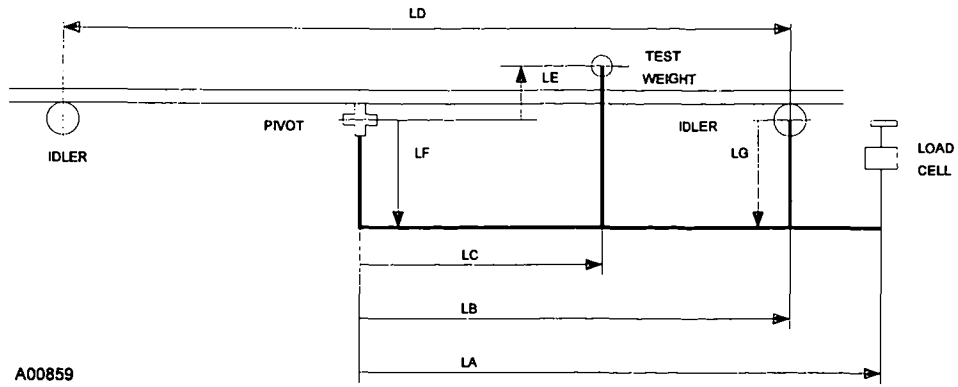

A00859

Model 10-20-1

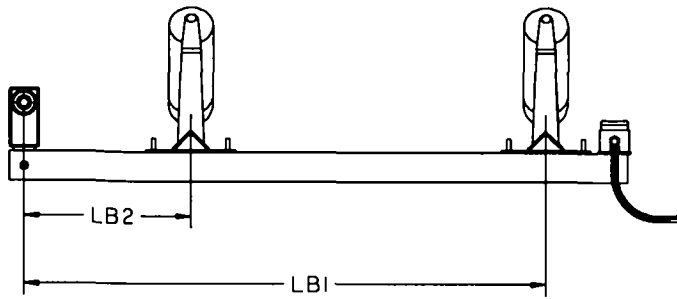

A00888

Model 10-22

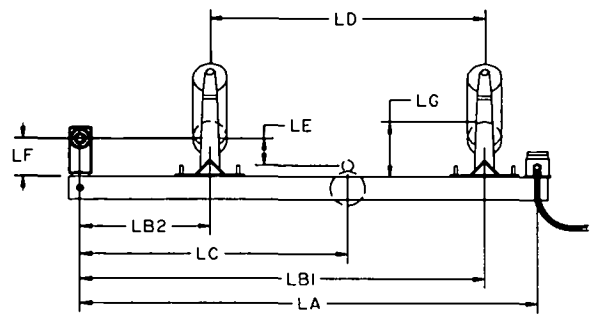

A00933

Model 10-17-2

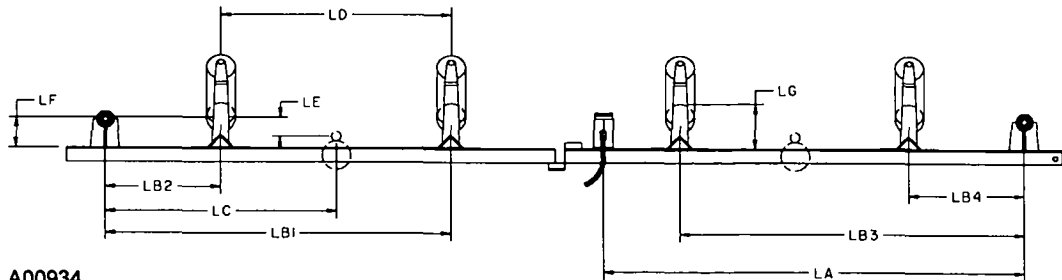

A00934

Model 10-17-4

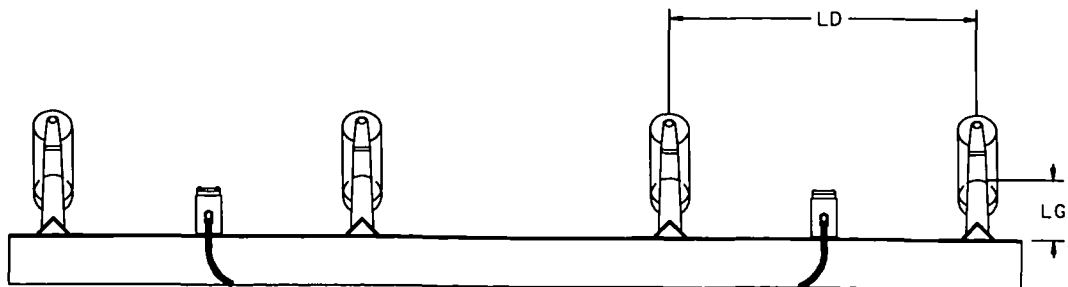

A00935

Model 10-14-4
TYPICAL WEIGHBRIDGES
FIGURE A/1-1

1.1 RULES FOR ENTERING THE PARAMETERS

L.C.	Must be entered
Idlers	Must be entered
LA	Defaults to one if zero is entered
LB1	Defaults to one if zero is entered
LB2	Defaults to LB1 if zero is entered
LB3	Defaults to LB1 if zero is entered
LB4	Defaults to LB1 if zero is entered
LB5	Defaults to LB1 if zero is entered
LB6	Defaults to LB1 if zero is entered
LC	Defaults to one if zero is entered
LD	Must be entered
LE	Defaults to zero
LF	Defaults to zero
LG	Defaults to zero

1.2 TABLES OF RAMSEY WEIGHBRIDGES

The tables at the end of this appendix show the default value for scale model selections, no value means that the parameter is not useful for that scale model and it is not displayed.

Under scored dimensions are in metric.

TABLE OF RAMSEY WEIGHBRIDGES									
#	MODEL BELT WIDTH	L.C. IDLERS	LA	LB1 LB2 LB3 LB4 LB5 LB6	LC	LD	LE	LF LG	mVV
1	10-20-1 18-36	1 1	32	24	24	36	0	6.5 6.5	3.00
2	10-20-1 42-72	1 1	32	22.75	22.75	36	0	6.5 7	3.00
3	10-20-1 24-36	2 1	32	24	24	36	0	6.5 6.5	3.00
4	10-20-1 42-84	2 1	32	22.75	22.75	36	0	6.5 7	3.00
5	10-20-2	1 2	36	18	18	36	0	6.5 7	3.00
6	10-20-2	1 2	48	24	24	48	0	6.5 7	3.00
7	10-20-1 18-36	1 1	32	24	38	36	4.5	6.5 6.5	3.00
8	10-20-1 42-72	1 1	32	22.75	38	36	4.5	6.5 7	3.00
9	10-20-1 24-36	2 1	32	24	38	36	4.5	6.5 6.5	3.00
10	10-20-1 42-84	2 1	32	22.75	38	36	4.5	6.5 7	3.00
11	10-22 18-36	1 2	62	54 18	38	36	4.75	6.5 6.5	3.00
12	10-22 18-36	1 2	71	63 21	42	42	4.75	6.5 6.5	3.00
13	10-22 18-36	1 2	80	72 24	48	48	4.75	6.5 6.5	3.00
14	10-22 42-48	1 2	62	52.75 16.75	36	36	4.75	6.5 7	3.00
15	10-22 42-48	1 2	71	61.75 19.75	42	42	4.75	6.5 7	3.00
16	10-22 42-48	1 2	80	70.75 22.75	48	48	4.75	6.5 7	3.00

TABLE OF RAMSEY WEIGHBRIDGES									
#	MODEL BELT WIDTH	L.C. IDLERS	LA	LB1 LB2 LB3 LB4 LB5 LB6	LC	LD	LE	LF LG	mVV
17	10-22 18-36	1 2	62	54 18	72	36	4.5	6.5 6.5	3.00
18	10-22 18-36	1 2	71	63 21	81	42	4.5	6.5 6.5	3.00
19	10-22 18-36	1 2	80	72 24	90	48	4.5	6.5 6.5	3.00
20	10-22 42-48	1 2	62	52.75 16.75	72	36	4.5	6.5 7	3.00
21	10-22 42-48	1 2	71	61.75 19.75	81	42	4.5	6.5 7	3.00
22	10-22 42-48	1 2	80	70.75 22.75	90	48	4.5	6.5 7	3.00
23	10-22 18-36	1 2	62	64 18	54	36	0	6.5 6.5	3.00
24	10-22 18-36	1 2	71	63 21	63	42	0	6.5 6.5	3.00
25	10-22 18-36	1 2	80	72 24	84	48	0	6.5 6.5	3.00
26	10-22 42-48	1 2	62	52.75 16.75	66	36	0	6.5 7	3.00
27	10-22 42-48	1 2	71	61.75 19.75	75	42	0	6.5 7	3.00
28	10-22 42-48	1 2	80	70.75 22.75	84	48	0	6.5 7	3.00
29	10-20-WF	1 1	32	24	24	30	-2	4 4	3.00
30	10-20-WF	1 1	32	22.75	22.75	30	-2	4 4	3.00
31	10-20-WF	1 1	32	24	36	30	2	4 4	3.00
32	10-20-WF	1 1	32	22.75	36	30	2	4 4	3.00

TABLE OF RAMSEY WEIGHBRIDGES									
#	MODEL BELT WIDTH	L.C. IDLERS	LA	LB1 LB2 LB3 LB4 LB5 LB6	LC	LD	LE	LF LG	mVV
33	10-17-2	2 2	64	54 18	36	36	-4.75	6.5 7	3.00
34	10-17-2	2 2	76	63 21	42	42	-4.75	6.5 7	3.00
35	10-17-2	2 2	88	72 24	48	48	-4.75	6.5 7	3.00
36	10-17-2	2 2	76	63 23.62	43.31	$\frac{1000}{39.37}$	-4.75	6.5 7	3.00
37	10-17-2	2 2	88	72 24.75	48.38	$\frac{1200}{47.24}$	-4.75	6.5 7	3.00
38	10-17-4	2 4	64	54 18	36	36	0	6.5 7	3.00
39	10-17-4	2 4	76	63 21	42	42	0	6.5 7	3.00
40	10-17-4	2 4	88	72 24	48	48	0	6.5 7	3.00
41	10-17-4	2 4	66	63 23.62	43.31	$\frac{1000}{39.37}$	0	6.5 7	3.00
42	10-17-4	2 4	88	72 24.75	48.31	$\frac{1200}{47.24}$	0	6.5 7	3.00
43	10-14-3	4 3				36			3.00
44	10-14-3	4 3				42			3.00
45	10-14-3	4 3				48			3.00
46									
47	10-14-4	4 4				36			3.00
48	10-14-4	4 4				42			3.00

TABLE OF RAMSEY WEIGHBRIDGES									
#	MODEL BELT WIDTH	L.C. IDLERS	LA	LB1 LB2 LB3 LB4 LB5 LB6	LC	LD	LE	LF LG	mVV
49	10-14-4	4 4				48			3.00
50	10-14-4	4 4				54			3.00
51	10-14-4	4 4				<u>1000</u> 39.37			3.00
52	10-14-4	4 4				<u>1200</u> 47.24			3.00
53	10-30	1 1				36			1.80
54	10-11 18-42	1 1	55.5	48	40	36	6.5	6.5 6.5	3.00
55	10-11 48-72	1 1	56.5	48	40	36	7	7 7	3.00
56	10-12	1 2	66	48	40	36	7	7 7	3.00
57	10-17-2D	2 2	40	24 24	24	48	0	6.5 7	3.00
58	10-17-2D	2 2	34	21 21	21	42	0	6.5 7	3.00
59	10-17-2D	2 2	28	18 18	18	36	0	6.5 7	3.00
214	10-101R-2	1 1				<u>1000</u> 39.37			2.00
215	10-101R-2	2 1				<u>1000</u> 39.37			2.00

APPENDIX A/2 LINEARIZATION

2.0 GENERAL

Request REC 3909 from factory.

RAMSEY PRODUCTS
DIGITAL INPUT/OUTPUT
TABLE OF CONTENTS

<u>CHAPTER</u>	<u>TITLE</u>	<u>PAGE</u>
APPENDIX A/3		
3.0	GENERAL	A/3-2
3.1	MOTHER BOARD DIGITAL I/O	A/3-2
3.1.1	Digital Inputs	A/3-2
3.1.2	Digital Outputs	A/3-2
3.2	DIGITAL INPUT/OUTPUT BOARD CONFIGURATION	A/3-3
3.2.1	16 In/4 Out DIO Board Specification (Figure A/3-4)	A/3-5
3.2.2	4 In/16 Out DIO Board Specification (Figure A/3-4)	A/3-5
3.3	BCD INPUT OPTION	A/3-7

APPENDIX A/3 DIGITAL INPUT/OUTPUT

3.0 GENERAL

The integrator has provision for up to 24 programmable digital inputs and 24 programmable digital outputs. Located on the Mother Board are two speed inputs, two programmable inputs, three programmable outputs, and one non-programmable Micro-Tech hardware fault output. One speed input is defaulted to a programmable input unless the belt slip option is installed.

Optional DIO boards can be added if additional I/O is required.

3.1 MOTHER BOARD DIGITAL I/O

3.1.1 Digital Inputs

- (2) speed and (2) programmable digital (DC) inputs (Figure A/3-1)
 - optically isolated
 - powered by internal +24 V DIO supply, 6 mA maximum
 - Cable Length: 150 ohm maximum. (7500 ft of 20 AWG)

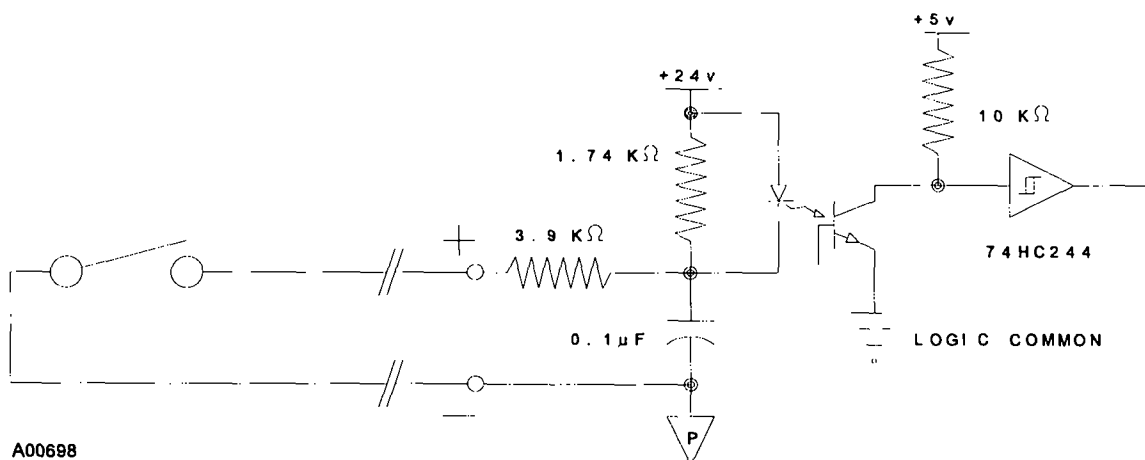

GENERAL PURPOSE DIGITAL INPUTS
FIGURE A/3-1

3.1.2 Digital Outputs

- (3) programmable and (1) non-programmable failure digital open collector outputs (Figure A/3-2)
 - able to drive TTL, CMOS, or relay solenoids
 - current sinking socketed drivers
 - +24 VDC internal supply, 100 mA DC maximum per output
 - failure output is "fail safe", turns off under fault condition

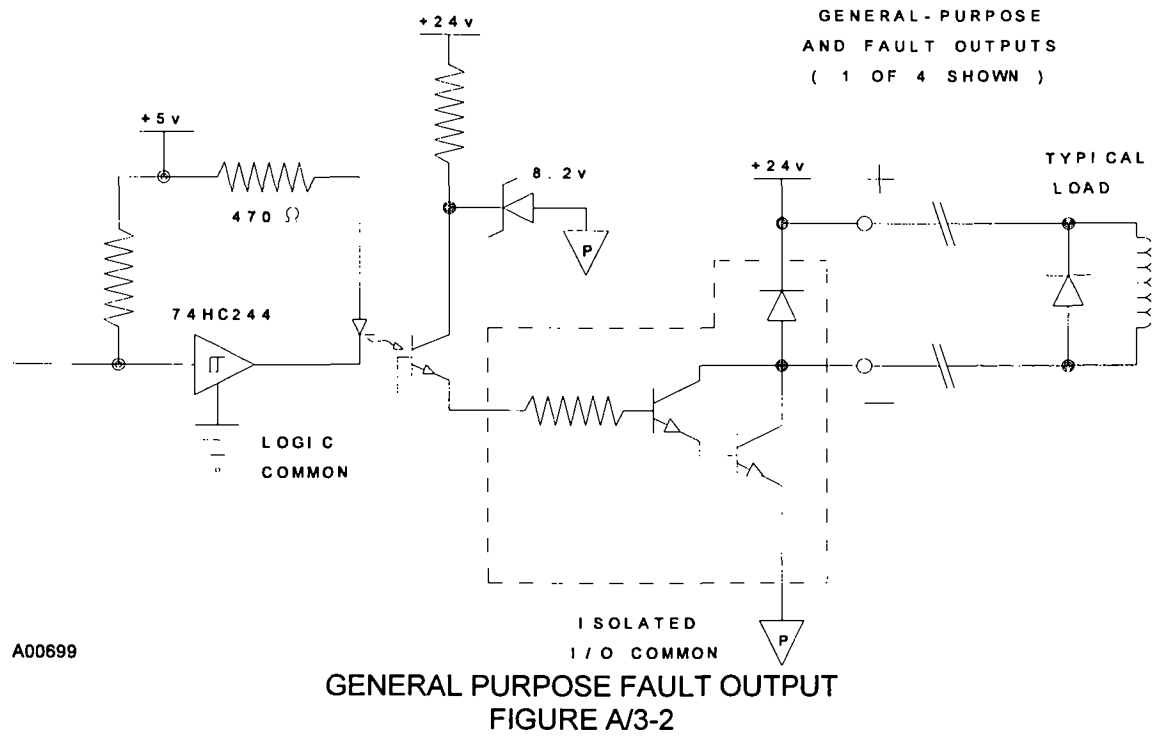

A00699

3.2 DIGITAL INPUT/OUTPUT BOARD CONFIGURATION

In addition to the programmable digital inputs and outputs on the Mother board, optional Digital I/O (DIO) expansion boards can be added. Available boards are DIO input board 16 inputs/4 outputs, output board 16 outputs/4 inputs or 20 inputs/20 outputs by adding both boards.

Both DIO boards provide isolated contact closure inputs and 24 volt current sinking (default) or current sourcing (consult Factory) isolated outputs. The DIO input board connector J16 is a male 25 pin sub-miniature D connector and the DIO output board connector J15 is a female connector.

Internal or external 24 VDC power for the DIO boards is controlled by selectable jumpers OP1 and OP2 located on the lower right hand side of the DIO boards (Figure A/3-3). All inputs and outputs use the same selected power supply. See table below for jumper positions.

JUMPERS		
POWER SOURCE	OP1	OP2
Internal	"A"	"A"
External	"B"	"B"

[Default]

The isolated contact closure inputs are activated by completing the circuit from the input to the negative side of the 24 VDC supply. Approximately 6 mA of current flows out of each input during contact closure.

The outputs of the DIO boards use 2803 current sinking (default) type IC's. The output IC's are installed in sockets to allow replacing the output IC only, rather than the board if the IC is damaged.

The output IC's can be replaced with 2981 type IC's for current sourcing applications. Wire jumpers W1 thru W4 must be relocated for current sourcing (see Figure A/3-3). In most cases, it is recommended that the boards be returned to the factory for converting from current sinking (default) to current sourcing. See table below for jumper positions.

JUMPERS				
CURRENT	W1	W2	W3	W4
Sinking	"Yes"	"No"	"Yes"	"No"
Sourcing	"No"	"Yes"	"No"	"Yes"

[Default]

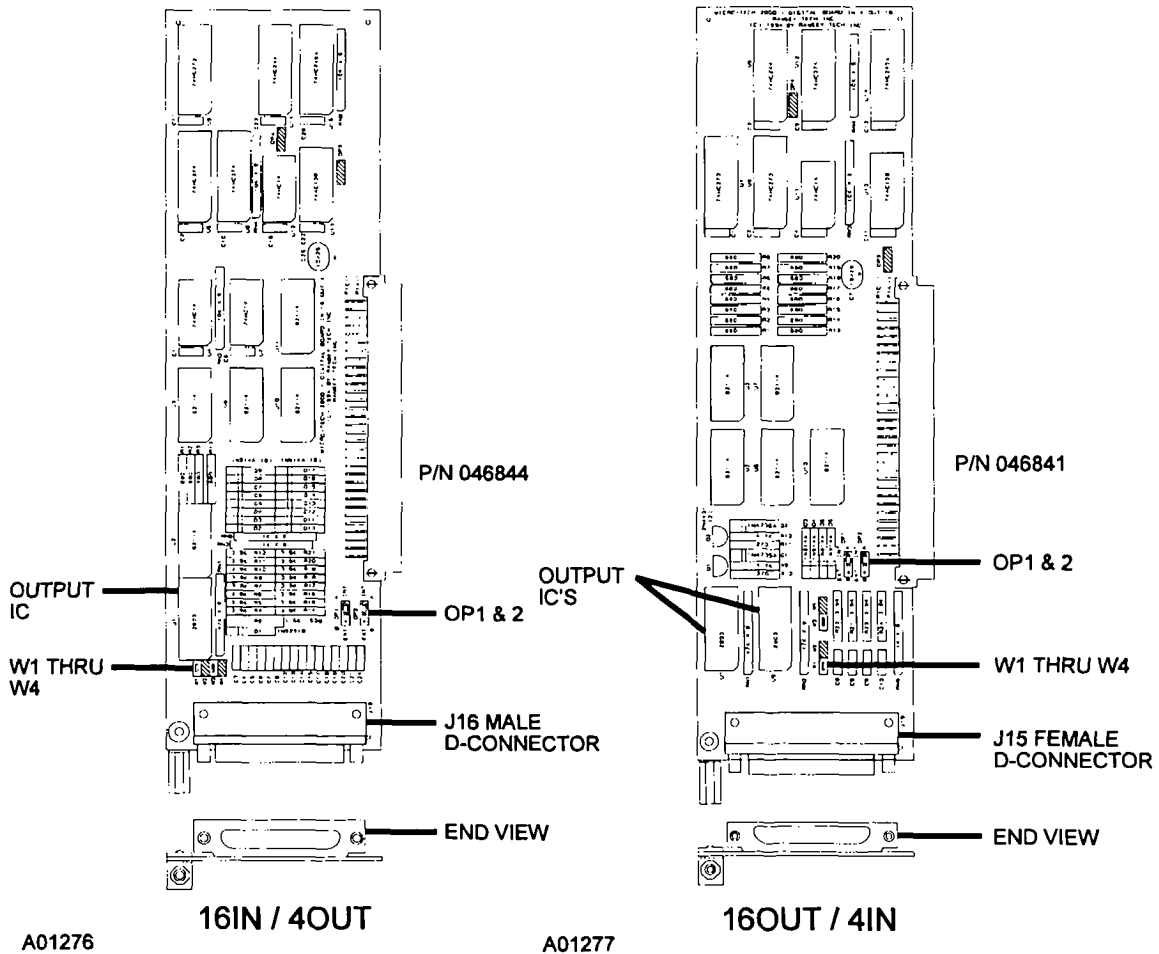

DIGITAL INPUT/OUTPUT BOARDS
FIGURE A/3-3

3.2.1 16 In\4 Out DIO Board Specification (Figure A/3-4)

1. (16) programmable inputs
See Section 3.1.1 specifications.
2. (4) programmable outputs
See Section 3.1.2 specifications.
3. Connector
25 pin D connector (male). Connector is intermateable with a 20 or 22 pin subminiature D connector dimensionally complying with MIL-C-24308.

3.2.2 4 In\16 Out DIO Board Specification (Figure A/3-4)

1. (4) programmable inputs
See Section 3.1.1 specifications.
2. (16) programmable outputs
See Section 3.1.2 specifications.
3. Connector
25 pin D connector (female). Connector is intermateable with a 20 or 22 pin subminiature D connector dimensionally complying with MIL-C-24308.

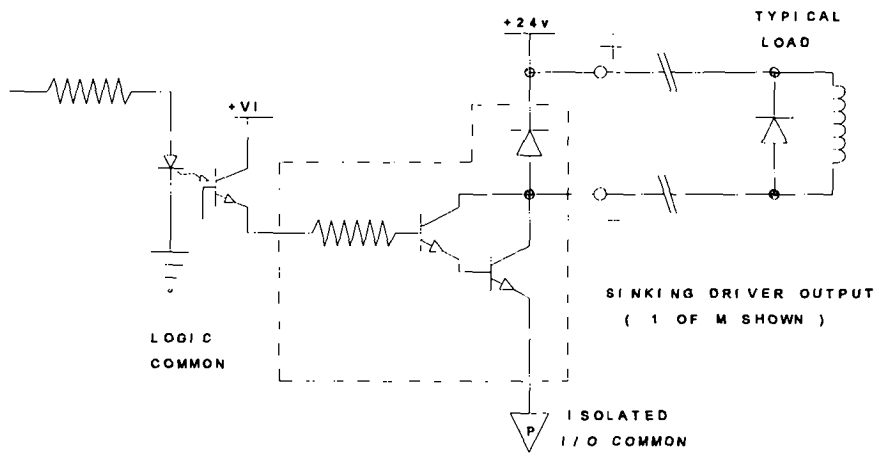
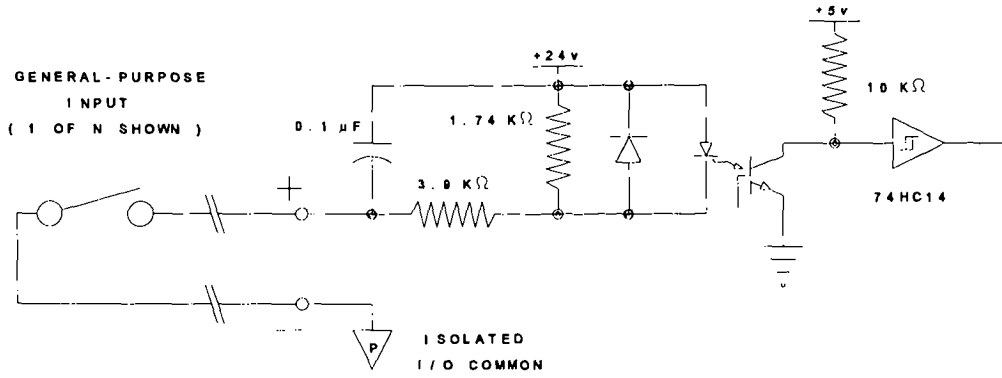

OR:

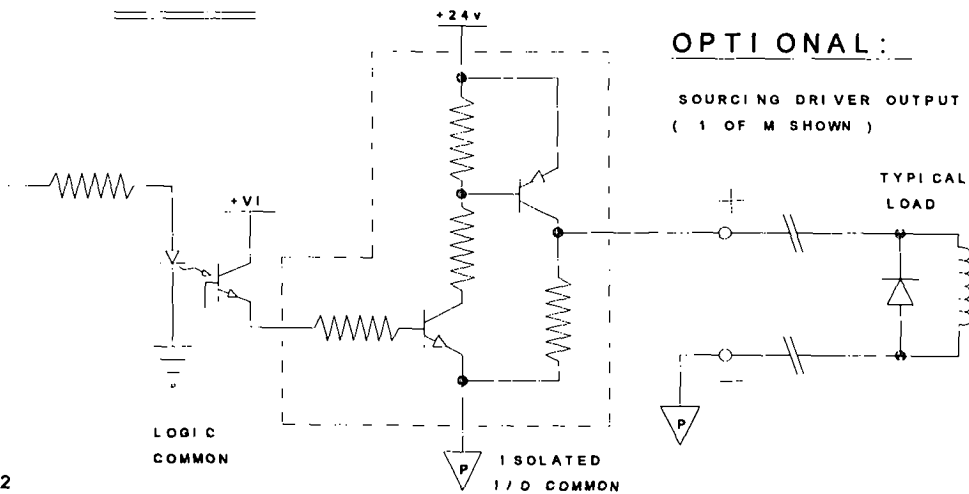

A00702

**DIGITAL INPUT/OUTPUTS
FIGURE A/3-4**

3.3 BCD INPUT OPTION

Load sizes for load out or batching applications can be remotely entered by BCD. An optional Load Out input output board is required.

See Figure A/3-5 for wiring.

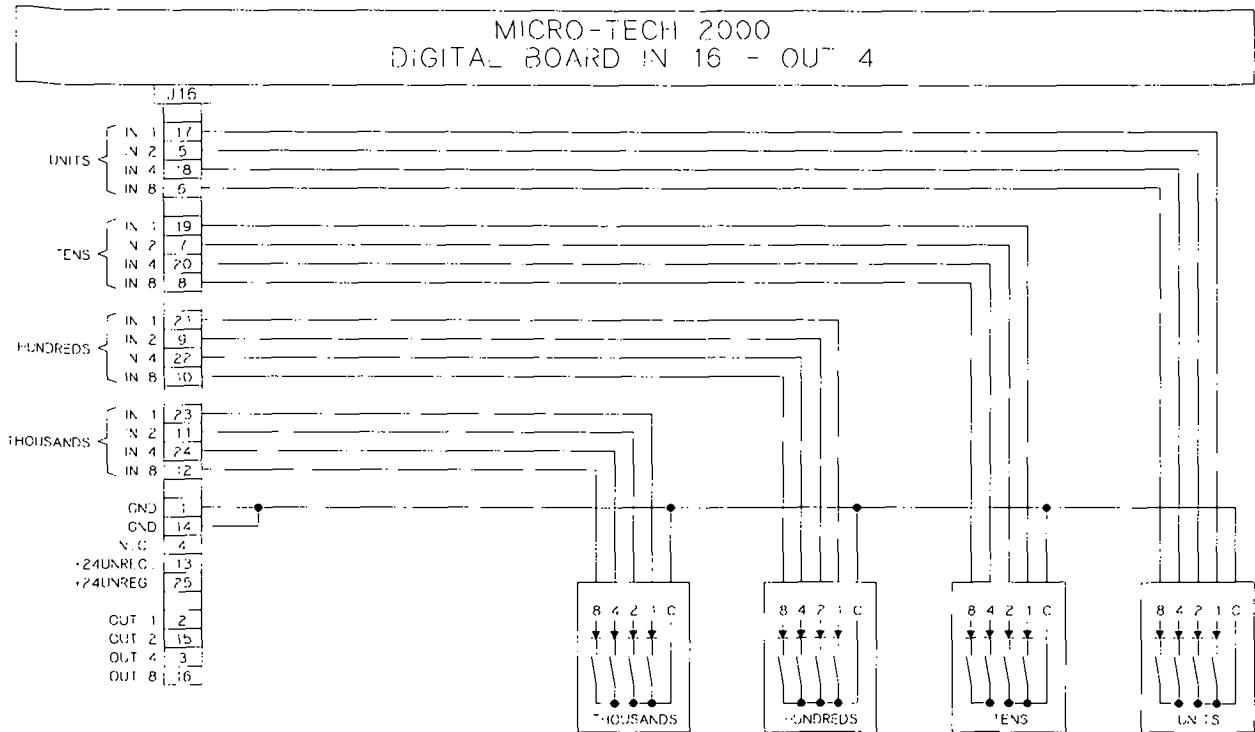

A01278

BCD INPUT
FIGURE A/3-5

**APPENDIX A/4
MICRO-TECH 2101 MENUS**

<u>SECTION</u>	<u>TITLE</u>	<u>PAGE</u>
4.0	MENU DISPLAYS	A/4-2
4.1	MAIN MENU 1	A/4-3
	4.1.1 Zero Calibrate Scroll	A/4-3
	4.1.2 Span Calibration Scroll	A/4-5
	4.1.3 Material Span Calibration	A/4-10
4.2	MAIN MENU 2	A/4-14
	4.2.1 Display	A/4-14
	4.2.2 Scale Data	A/4-18
	4.2.3 Calibration Data	A/4-27
4.3	MAIN MENU 3	A/4-37
	4.3.1 Changing the Protection Level	A/4-37
	4.3.2 Diagnostics	A/4-39
	4.3.3 Tests	A/4-44
4.4	MAIN MENU 4	A/4-49
	4.4.1 I/O Definition	A/4-49
	4.4.2 Alarms Definition	A/4-60
4.5	MAIN MENU 5	A/4-64
	4.5.1 Communication A Scroll	A/4-64
	4.5.2 Print	A/4-68
	4.5.3 The PRINT Key	A/4-76
4.6	MAIN MENU 6	A/4-78
	4.6.1 Audit Trail	A/4-78
	4.6.2 Linearization	A/4-79

APPENDIX A/4 MT2101 MENUS

4.0 MENU DISPLAYS

The integrator is a menu driven machine that allows the operator to access all setup, test and calibration parameters. Main Menu screens 1 through 6 can be accessed at anytime by pressing the **MENU** key until the desired menu screen is displayed. Menu scrolls may be selected by pressing the soft key directly below the desired scroll, and then using the Up/Down scroll key.

If the integrator is password protected, the appropriate password must be entered prior to making changes or performing routine calibration. Menus may be viewed without entering a password, but no entries are allowed unless the password is entered.

Optional menu scrolls are only available if the available option has been installed. The following screens are activated by the **MENU** key.

```
- MAIN MENU 1 -  
Press MENU for more  
ZERO SPAN MAT'L  
CAL CAL CAL
```

```
- MAIN MENU 2 -  
Press MENU for more  
SCALE CALIB  
DISPLAY DATA DATA
```

```
- MAIN MENU 3 -  
Press MENU for more  
PROT DIAG TEST
```

```
- MAIN MENU 4 -  
Press MENU for more  
I/O ALARMS LOAD  
DEF. DEFIN. OUT
```

```
- MAIN MENU 5 -  
Press MENU for more  
COMM A COMM B PRINT  
*
```

* Can be AB RIO or
PRO DP

```
-      MAIN MENU 6      -  
Press MENU for more  
AUDIT  
TRAIL  LINEAR
```

4.1 MAIN MENU 1

Main Menu 1 contains the Calibration Menu. Menu 1 is selected by pressing the **MENU** key until Main Menu 1 appears. Desired calibration scrolls are selected by pressing the soft keys directly below the desired scroll.

```
-      MAIN MENU 1      -  
Press MENU for more  
ZERO      SPAN      MAT'L  
CAL      CAL      CAL
```

4.1.1 Zero Calibrate Scroll

The zeroing process is implemented as a machine directed procedure.

- 1. Auto Zero

```
-      ZERO CAL      -  
Run belt empty, then  
press START.  
START  EXIT  MANUAL
```

Pressing the **EXIT** soft key returns the operator to Main Menu 1. Pressing **MANUAL** advances to Step 2 below. Pressing **RUN** at any time returns to the Run Menu.

The belt must be running during Auto Zero, since a complete zeroing procedure requires at least one full revolution of the belt to be averaged.

When **START** is pressed, the following screen is displayed.

```
AUTO ZEROING  
Time remaining 0000  
Rate: 000.0 Tph  
Tot 000000 Tons
```

During Auto Zero, resolution of the total is ten times higher than normal. The number of seconds in Line 2 is calculated based on the current speed, and corresponds to the time remaining for completing the test. If the belt is not running at the moment the test is started or it is stopped during the test, a message is displayed, indicating the procedure has been aborted.

```
WARNING Belt stopped  
Calibration aborted.
```

```
EXIT
```

EXIT returns to Main Menu 1. When zero is reached, the system automatically displays the following screen.

```
AUTO ZERO COMPLETE  
Error ±000.00%  
Change zero?  
YES    NO    ADV
```

The word "COMPLETE" is flashing. Pressing **ADV** changes from Error % to Accumulated Weight. The percentage of error is related to full scale capacity.

Pressing **NO** returns the screen to Main Menu 1 without changing the zero number.

When **YES** is pressed, the zero number is changed and the next screen appears.

```
ZERO # CHANGED  
New zero # 00000  
Old zero # 00000  
RUN      MENU  ADV
```

ADV changes from "Old zero" to "Rate", to "Accumulated Weight", and to "Error %".

Press **MENU** to repeat Auto Zero calibration. Press **RUN** to return to the Run Menu.

2. Manual Zero

The Manual Zero procedure shows the zero constant and allows direct entry if known. Use the **ENTER** key to confirm the new number.

```
-  MANUAL ZERO  -  
Rate   000.0 Tph  
Zero # 00000  
ENTER  EXIT    ADV
```

Password: Operator

```
Default:    40000  
Min:        0  
Max:        120000
```

The **ADV** key is only displayed if Auto Zero Tracking option is enabled. The AZT function accurately tracks the zero of the scale by calculating an additional zero constant. The portion of zero due to AZT is not incorporated in the zero constant, but is shown separately.

When **ADV** is pressed, the system scrolls between Zero and AZT:

```
-  MANUAL ZERO  -  
AZT # ±000000  
AZT % ±000000  
ENTER  EXIT    ADV
```

Password: Operator

When the AZT is displayed, the **ENTER** key incorporates the AZT number into the Zero constant, so the displayed AZT number and percentage changes to zero.

4.1.2 Span Calibration Scroll

Three simulated load span calibration options are available: R-Cal, Test Weights and Test Chain. Test Weights or Test Chains require additional hardware and handling equipment.

The system allows the operator to select which one of the three methods is to be used for routine calibration. The selection is made in Main Menu 2, CAL DATA Scroll 1.

1. Auto Span
 - A. Starting an R-Cal Calibration

Press the **SPAN CAL** soft key. The following screen appears.

```
- AUTO SPAN R Cal -  
Run belt empty, then  
press START.  
START  EXIT  MANUAL
```

Pressing the **EXIT** soft key or **MENU** control key returns the screen to Main Menu 1.

Press **START** to initiate R-Cal span calibration. There is no totalization for three seconds until the weight signal has stabilized. Go to Step D below.

- B. Starting a Chain Calibration

Stop the conveyor belt.

Apply chains on conveyor belt.

Press **SPAN CAL** soft key. The following screen appears.

```
- AUTO SPAN Chain -  
Press START to begin  
chain calibration.  
START  EXIT  MANUAL
```

Password: Operator

Press **START** to disengage the Master Tons counter. The following screen appears.

```
- AUTO SPAN Chain -  
Apply chain, then  
press START.  
START  EXIT  MANUAL
```

Password: Operator

Pressing the **EXIT** soft key or **MENU** control key returns the screen to Main Menu 1.

When **START** is pressed, the following screen appears.

```
- AUTO SPAN Chain -  
Run belt, then  
press START.  
START  EXIT
```

Restart conveyor belt and insure chain placement is proper.

Press **START**.

Go to Step D below.

C. Starting a Test Weights Calibration

Stop the conveyor belt if necessary to apply test weights.

Press the **SPAN CAL** soft key. The following screen appears.

```
- AUTO SPAN Weights-  
Press start to begin  
weight calibration.  
START  EXIT  MANUAL
```

Password: Operator

Press **START** to disengage the Master Tons counter. The following screen appears.

```
- AUTO SPAN Weights-  
Apply weights, then  
press START.  
START  EXIT  MANUAL
```

Password: Operator

If the "LOAD WTS" output has been selected in the I/O Definition Scroll, test weights are automatically loaded after START is pressed. Wait for test weights to be loaded before proceeding. The message displayed will be "Press START to load test weights".

Pressing **EXIT** returns the screen to Main Menu 1.

Apply test weights.

When **START** is pressed, the following screen appears.

```
- AUTO SPAN Weights-  
Run belt, then  
press START.  
START  EXIT
```

Password: Operator

Restart the conveyor belt if it is not running and press **START**.

Go to Step D below.

D. Executing the Span Calibration

Whichever method has been used to start automatic span calibration, after **START** is pressed, the following screen is displayed.

NOTE: Entry point when REPEAT is pressed (see below).

```
AUTO SPANNING  
Time remaining 0000  
Rate 000.0 Tph  
Tot 000000 Tons
```

During Auto Span, the resolution of the total is ten times higher than normal. The time remaining shown in Line 2 is calculated upon the current speed, and it is based on the test duration. If the belt is stopped during the test, a message is displayed indicating the procedure has been suspended. No action is required from the operator at this stage, just wait until the test is completed.

E. Material Factor

This part of the procedure is only executed if a material calibration is done before, and the current simulated method has no material factor installed.

NOTE: If a calibration with material has not been run before, or a manual span entry is done, or this is not the first time the current simulated load method is used, this section does not apply. Go to Step F below.

It is very important to understand that when this procedure is executed, the system does not alter the span. The span is assumed to be correct because it was obtained from a test with material. The system acquires the Material Factor for the current calibration method instead. This

means the integrator knows in the future how to use this method for correctly changing the system's span.

```
AUTO SPAN COMPLETE
Error +/-00.00 %
Unfactored Calcon
EXIT FACTOR REPEAT
```

The word "COMPLETE" is flashing. If **EXIT** is pressed, the system acknowledges the Material Factor is not used. The effect of this is the system does not ask for a material factor any more for this calibration method until a manual span entry is done. By pressing **EXIT** the operator tells the system that material factors is not desired, but wants to use the test results for changing the span number. After **EXIT** is pressed, go to Step F below. If **REPEAT** is pressed go to Step D above.

If **FACTOR** is pressed, the following screen is displayed.

```
R-CAL Mat1 FACTOR
New factor: 000.00 %
Change factor?
YES      NO      ADV
```

Can be R-CAL or WTS or CHAINS

ADV advances to Old factor and again to New factor. If **NO** is pressed, the Material Factor is set to 1.00 (see above), then go to Step F below.

If **YES** is pressed, the following screen is displayed.

```
R-CAL Mat1 FACTOR
Old factor: 00.00 %
New factor: 00.00 %
RUN MENU REPEAT
```

Can be R-CAL or WTS or CHAINS

The **REPEAT** key returns the operator to Step D above. **RUN** and **MENU** can be used for ending the procedure. After this point is reached, the system does not proceed to the next section.

F. Recording New Span

The system calculates the new span based on the result of the test performed with the simulated method.

```
AUTO SPAN COMPLETE
Error +/-00.00 %
Change span?
YES      NO      ADV
```

The word "COMPLETE" is flashing. Pressing **ADV** advances to Accumulated Weight, Cal Con, Material Factor and back to Error %. If the Material Factor is INVALID (never acquired before), it is not displayed.

If **YES** is pressed, the following screen is displayed.

```
SPAN # CHANGED
Old span # 000000
New span # 000000
RUN   REPEAT  ADV
```

ADV changes from Error % to Accumulated Weight, Calcon, Old Span, Material Factor (only if not INVALID). **REPEAT** moves back to Step D above and calibration restarts.

If **NO** is pressed, the following screen is displayed.

```
SPAN UNCHANGED
Old span # 000000
New span # 000000
RUN   REPEAT  ADV
```

ADV changes from Error % to Accumulated Weight, Calcon, Old Span, and Material Factor.

REPEAT moves back to Step D above and calibration restarts. Please note the Old span and New span are shown equally. This is because no change to the span has been done.

G. Ending an Auto Span Procedure with Chains or Test Weights

In case of auto-span with chains or weights, after **RUN** is pressed, the following screen is displayed.

```
Remove chains (or weights)
before returning to
normal operation!!
RUN   MENU
```

Pressing **RUN** resumes totalization and moves to the RUN Scroll.

H. Ending an Auto Span Procedure with R-Cal

In case of auto-span with R-Cal, after **RUN** is pressed, the R-Cal relay is deenergized and the display is locked for three seconds.

2. Manual Span

If the span constant is known, the manual span procedure allows the operator to make a direct a change of span.

```
-   MANUAL SPAN   -  
Rate   000.0 Tph  
Span # 0000000  
ENTER EXIT RUN
```

Password: Operator

Default: 300000
Min: 222223
Max: 20000002

The **EXIT** key returns the operator to Main Menu 1.

It is very important to note that entering the Manual Span sets the material factors to **INVALID** (if any). This means that the automatic span tests need to be run again after a manual span entry has been performed, in order to acquire the material factors again.

4.1.3 Material Span Calibration

Material span calibration is a machine directed procedure for calibrating the belt scale using actual material.

Preweighed or postweighed material, having been weighed to a known accuracy on a static scale, passes across the belt scale. This procedure automatically adjusts the integrator span and factors all simulated load test Cal Cons if the operator prefers they be factored.

1. Material Calibration Procedure

A. Starting the Test

Press **MAT'L CAL** soft key and **DOWN ARROW**. The following screen appears.

```
MAT'L CALIBRATION  
Run belt empty, then  
press START.  
START MENU
```

The operator must run the belt for at least one minute or one belt revolution before proceeding. After **START** is pressed, the master weight totalizer is disengaged.

When **START** is pressed, the following screen appears.

```
Run quantity of  
material over scale.  
  
CONTINUE
```

Press **CONTINUE** to go to the next scroll and follow the test procedure.

B. Running the Test with Material

```
      00000.0 Tons
      0000.0 Tph
Press DONE to end
DONE   ABORT
```

During the material calibrate procedure, the resolution of total tons counted is ten times higher than normal.

Wait until all material has passed over the scale, then press DONE. Pressing ABORT forces the program back to the top of the MAT'L CAL Scroll.

C. Entering the Reference Weight

At the end of the test, the system asks the operator whether the (actual) weight of the material is already known.

```
0000.00 Tons
Ref. weight known?
YES     NO
```

Press NO if the reference (actual) weight will not be known for some time and the conveying systems need to be returned to run. If NO is pressed, the RUN screen appears. MAT'L will be flashing to remind the operator that the material test is incomplete.

Press MAT'L when the reference weight is known and enter in the following screen.

If YES was answered before, or if the MAT'L key had been pressed after NO, the following screen appears.

```
00000.00 Tons
Enter reference
weight 00.0 Tons
ENTER   ABORT
```

The operator has to enter the actual material weight in the same weight units as the integrator is setup for. Example: Convert pounds to the nearest hundredth (0.01) of a ton and enter if the integrator is set up for tenths (0.1) of a ton increments. Material calibration is running at ten times normal.

After the material weight is entered, press ENTER to confirm.

If ABORT is pressed, the information acquired during the test is lost and the system returns to Main Menu 1 screen.

D. Updating the Span Constant

After the amount of material has been entered, the following screen is displayed.

```
MAT'L CAL. COMPLETE
Error 000.00 %
Change span?
YES      NO      ADV
```

The word "COMPLETE" is flashing. Pressing ADV changes from Error % to Actual Difference of Total. Pressing NO moves to "Add reference weight to total".

E. Acquiring the Material Factors

If YES was pressed, the following screen is displayed confirming the new span constant was installed. At this point, the scale is calibrated to the actual material test.

```
SPAN # CHANGED
New span # 000000
Old span # 000000
RUN      MENU  FACTOR
```

If FACTOR is pressed, the following screen is displayed.

```
MAT'L CALIBRATION
Automatic correction
to Material Factors
R-CAL  WTS  CHAIN
```

Of the three simulated load calibration methods, only the ones that have been already used are shown. It is not possible to calculate a material factor if a simulated test was not run before the material test. If none of the three was done, the FACTOR soft key in the previous scroll is not displayed.

If R-CAL or WTS or CHAIN is pressed:

```
R-CAL Matl FACTOR
New factor 000.00 %
Change factor?
YES      NO      ADV
```

Can be R-CAL or WTS or CHAINS

Pressing ADV advances to the Old factor and again to the New factor. YES goes to the next scroll. NO goes back to Step E above. Press YES if this specific simulated method of calibration has already been used and the related material factor will be recorded. By doing this, the system is able to execute accurate calibrations in the future with this simulated

method. Press NO if the acquired material factor is not desired. If YES is pressed, the following screen is displayed.

```
R-CAL Matl FACTOR
Old factor: 00.00 %
New factor: 00.00 %
RUN MENU FACTOR
```

Can be R-CAL or WTS or CHAINS

The FACTOR key repeats for all simulated test previously run. If RUN or MENU is pressed, the following screen is displayed.

F. Adding the Reference Weight to Total

```
MAT'L CALIBRATION
Add reference
weight to totals
YES NO
```

If YES is pressed, the amount of material used for the test is added to the master, reset and operator's totals. If the answer NO is selected, the information is lost.

NOTE: Moisture compensation is inhibited during material calibration. This is done to make the check of the totalized quantity easier. The static scale provides the weight of the material including moisture. The weight of the water is removed immediately before adding to total at the end of the procedure, so that the Master, Reset and Operator's totals are still correct.

4.2 MAIN MENU 2

Main Menu 2 contains the setup and configuration menus. Main Menu 2 is selected by pressing the **MENU** key until Main Menu 2 appears. Setup scrolls are selected by pressing the key directly below the desired scroll.

```
-   MAIN MENU 2   -  
Press MENU for more  
          SCALE  CALIB  
DISPLAY DATA  DATA
```

4.2.1 Display

1. Measure Units

```
- DISPLAY SCROLL 1 -  
Measure units  
> English <  
CHOICE  ENTER
```

Password: Service

Default: ENGLISH

Selections: ENGLISH, METRIC, MIXED

NOTE: If the Measure Units are changed from English to Metric (or vice versa) after the scale is calibrated, the span number will change but the calibration will remain the same.

The units to be used for totalization are selected here. Press **ENTER** soft key to accept the default unit, or **CHOICES** soft key to scroll selections. Press **ENTER** to confirm your selection. Scroll down.

```
- DISPLAY SCROLL 2 -  
Totalization Units  
> Tons <  
CHOICE  ENTER
```

Password: Service

If ENGLISH: Default: Tons

Selections: Tons, LTons, Pounds

If METRIC: Default: tonnes

Selections: tonnes, kg

If MIXED: Default: Tons

Selections: Tons, LTons, Pounds, tonnes, kg

Units used for parameters expressed in length are selected here. Selections are only available if **MIXED** units are in use. Press **ENTER** soft key to accept the default unit, or **CHOICES** soft key to scroll selections. Press **ENTER** to confirm your selection. Scroll down.

```
- DISPLAY SCROLL 3 -  
Length Units  
> feet <  
CHOICE ENTER
```

Password: Service

If ENGLISH: Default: Feet
If METRIC: Default: meters
If MIXED: Default: Feet
Selections: Feet, meters

The rate is displayed according to the units selected here. Press **ENTER** soft key to accept the default unit, or **CHOICES** soft key to scroll selections. Press **ENTER** to confirm your selection. Scroll down.

```
- DISPLAY SCROLL 4 -  
Rate Units  
> TPH <  
CHOICE ENTER
```

Password: Service

If ENGLISH: Default: Tph
Selections: Tph, LTph, Lb/h, Percent %, Lb/m, T/m, LT/m
If METRIC: Default: kg/h
Selections: t/h, kg/h, kg/m, t/m, Percent %
If MIXED: Default: Tph
Selections: Tph, LTph, Lb/h, Percent %, t/h, kg/h, kg/m, t/m, Lb/m, T/m, LT/m

The units used for entering the load cell capacity are specified here. In this particular case, the use of English or Metric units is always allowed. Press **ENTER** soft key to accept the default unit, or **CHOICES** soft key to scroll selections. Press **ENTER** to confirm your selection. Scroll down.

```
- DISPLAY SCROLL 5 -  
Load cell Units  
> Pounds <  
CHOICE ENTER
```

Password: Service

If ENGLISH or MIXED: Default: Pounds
If METRIC: Default: kilograms
Selections: Lbs, kg

2. Defining the Language

The Micro-Tech 2000 is a dual language instrument. English is always the first language, the second can be one from the following list. Press the **DOWN** scroll key.

```
- DISPLAY SCROLL 6 -  
Language  
> USA <  
CHOICE ENTER
```

Password: Service

Default: USA
Selections: USA, ESP (Spanish)

3. Setting Time and Date Mode

This section applies only if the COMM board is installed. The user has to define the format for displaying and printing time and date.

```
- DISPLAY SCROLL 7 -  
Time  
> am/pm <  
CHOICE ENTER
```

If USA or English: Default: am/pm
If other language: Default: 24 h
Selections: am/pm, 24 h

```
- DISPLAY SCROLL 8 -  
Date  
> MM-DD-YYYY <  
CHOICE ENTER
```

If USA: Default: MM-DD-YYYY
If other language: Default: DD-MM-YYYY
Selections: DD-MM-YYYY, MM-DD-YYYY,
YYYY-MM-DD

4. Setting Line 3 of the Run Menu

The Run Menu can be configured to display on line 3 either Belt Loading, Speed, Date and Time (if COMM is installed) or No Display (the default selection).

```
- DISPLAY SCROLL 9 -  
Run display line 3  
> No Display <  
CHOICE ENTER
```

Password: Operator

Default: NO DISPLAY

Selections: NO DISPLAY, LOAD, SPEED, DATE/TIME (Only if COMM board is installed)

5. Setting Damping Factors for the Display

The process variables when displayed on the screen can be damped by a programmable factor, to filter out variations that can be introduced by mechanical vibrations. To tune a damping filter, enter the number of seconds corresponding to the desired time constant. If for example 10 seconds is entered, the process variable reaches the stability after a step change in 10 seconds. This damping factor only affects the display, not the current output variable, which has a separate damping factor, selectable in Main Menu 4, I/O Define.

```
- DISPLAY SCROLL 10-  
Damping Display RATE  
Damping = 2 sec  
ENTER
```

Password: Operator

Default: 2 sec
Min: 0 sec
Max: 400 sec

The following screen is only displayed if RUN display line 3 is set to load.

```
- DISPLAY SCROLL 11  
Damping Display LOAD  
Damping = 2 sec  
ENTER
```

Password: Operator

Default: 2 sec
Min: 0 sec
Max: 400 sec

The following screen is only displayed if the Run display Line 3 is set to Speed:

```
- DISPLAY SCROLL 12-  
Damping Displ SPEED  
Damping = 2 sec  
ENTER
```

Default: 2 sec
Min: 0 sec
Max: 400 sec

4.2.2 Scale Data

Refer to Section 2.5.1 and Appendix A/1, Ramsey Weighbridge Physical Parameters.

1. Scale Capacity and Divisions

The first entry is the scale capacity, which is the maximum rate at which the scale is allowed to work. This entry also defines the default number of decimal places that are used for displaying rate. Use numeric keys for entering the number, confirm with **ENTER**. Scroll down.

```
- SC DATA SCROLL 1 -  
Max. scale capacity  
500.0 Tph  
ENTER
```

Password: Service

Default: 500.0
Min: 1
Max: 200000

When the Scale capacity is entered, the number of decimal places is also defined. If, for example, the User enters 500.0, this sets the "Scale Divisions" parameter to 0.1. Advancing to the next scroll, the User then sees first the Scale Division corresponding to the just entered Scale Capacity (in the example 0.1). If required, the User is able to alter the Scale Division to any of the available options.

Press the **ENTER** soft key to accept the default divisions, or the **CHOICES** soft key to scroll selections. Press **ENTER** to confirm your selection. Scroll down.

```
- SC DATA SCROLL 2 -  
Scale divisions  
> 0.1 <  
CHOICE ENTER
```

Password: Service

Default: 0.1
Selections: 0.1, 0.2, 0.5, 1, 2, 5, 10, 20, 50, 0.01, 0.02, 0.05, 0.001, 0.002, 0.005

2. Selecting the Weighbridge Model

By entering the code number of your Ramsey scale on the next screen, the Integrator automatically calculates parameters of the system such as number of load cells and number of weigh idlers. This entry is also used for internal calibration calculations. The default model number for the Model 2101 Integrator is 1, which corresponds to the belt scale model 10-20-1.

```

- SC DATA SCROLL 3 -
Belt scale code #
> 1 <
ENTER          DETAIL

```

Password: Service

Default: 1
 Min: 0
 Max: 500

Press **ENTER** to accept the displayed selection from the database listed in Appendix A/1, Ramsey Weighbridge Physical Parameters. If **ENTER** is used, the scrolls from 3A to 3J are not displayed. Skip to Step 4, Defining Dimensional Parameters of the Application.

Press **DETAIL** if you want to force the following scrolls 3A to 3O to be displayed even if **ENTER** was used.

Enter **0** if you want to define the weighbridge not using the database. This should only be done for special weighbridges not being part of the standard set of Ramsey scales. Entering **0** forces the following scrolls 3A to 3O to be displayed.

3. Detailing the Mechanical Parameters of the Frame

The following screens are only displayed if **OTHER** or **DETAIL** were pressed. Figure 1-1 in Appendix A/1, Ramsey Weighbridge Physical Parameters, can be used to identify the following parameters.

Parameter LA: pivot to Load cell distance: The distance from pivot to load cell should be measured to within 0.032 (1/32) inch (1 mm).

Using the numeric keys, enter the distance recorded in Section 2.5.1 and press **ENTER**. For weighbridges which do not have a pivot, enter zero.

```

- SC DATA SCROLL 3A-
Pivot to load cell
distance: 000.00 In
ENTER

```

Password: Service

If ENGLISH or MIXED:	If METRIC:
Default: 32 in	Default: 1000 mm
Min: 0.00 in	Min: 0 mm
Max: 150.00 in	Max: 3800 mm

This is the number of weigh idlers affixed to the scale weighbridge.

```
- SC DATA SCROLL 3B-  
# of weigh idlers  
1  
ENTER
```

Password: Service

Default: 1
Min: 1
Max: 6

Parameter LB1: Pivot to first weigh idler distance. Measure the distance between the pivot centerline and first weigh idler grease fitting. Enter the distance (within 0.032 inch or 1 mm) recorded in Section 2.5.1.

For weighbridges which do not have a pivot, enter zero.

```
- SC DATA SCROLL 3C-  
Pivot to 1st idler  
distance 000.00 In  
ENTER
```

Password: Service

If ENGLISH or MIXED:	If METRIC:
Default: 24 in	Default: 800 mm
Min: 0.00 in	Min: 0 mm
Max: 100.00 in	Max: 2500 mm

If the number of weigh idlers entered in scroll 3B is more than one, the following screens are displayed. Measure the distance between the pivot centerline and first weigh idler grease fitting. Enter the distance (within 0.032 inch or 1 mm) recorded in Section 2.5.1. For weighbridges which do not have a pivot, enter zero.

Only if # of weigh idlers ≥ 2 :

```
- SC DATA SCROLL 3D-  
Pivot to 2nd idler  
distance 000.00 In  
ENTER
```

Password: Service

If ENGLISH or MIXED:	If METRIC:
Default: 0.00 in	Default: 0 mm
Min: 0.00 in	Min: 0 mm
Max: 100.00 in	Max: 2500 mm

Only if # of weigh idlers >=3:

```
- SC DATA SCROLL 3E-  
Pivot to 3rd idler  
distance 000.00 In  
ENTER
```

Password: Service

If ENGLISH or MIXED:

Default: 0.00 in
Min: 0,00 in
Max: 100.00 in

If METRIC:

Default: 0 mm
Min: 0 mm
Max: 2500 mm

Only if # of weigh idlers >=4:

```
- SC DATA SCROLL 3F-  
Pivot to 4th idler  
distance 000.00 In  
ENTER
```

Password: Service

If ENGLISH or MIXED:

Default: 0.00 in
Min: 0.00 in
Max: 100.00 in

If METRIC:

Default 0 mm
Min: 0 mm
Max: 2500 mm

Only if # of weigh idlers >=5:

```
- SC DATA SCROLL 3G-  
Pivot to 5th idler  
distance 000.00 In  
ENTER
```

Password: Service

If ENGLISH or MIXED:

Default: 0.00 in
Min: 0.00 in
Max: 100.00 in

If METRIC:

Default: 0 mm
Min: 0 mm
Max: 2500 mm

Only if # of weigh idlers =6:

```
- SC DATA SCROLL 3H-  
Pivot to 6th idler  
distance 000.00 In  
ENTER
```

Password: Service

If ENGLISH or MIXED:

Default: 0.00 in

If METRIC:

Default: 0 mm

Min: 0.00 in Min: 0 mm
Max: 100.00 in Max: 2500 mm

NOTE: All measurements must be (within 0.032 inch or 1 mm) recorded in Section 2.5.1. Enter the distance with the numeric keys and press ENTER.

Parameter LE: Pivot to test-weight height. For weighbridges which do not have a pivot, enter zero. 3I, L, M and N only apply if test weights are provided for calibration.

```
- SC DATA SCROLL 3I-  
Pivot to test-weight  
height 000.00 In  
ENTER +/-
```

Password: Service

If ENGLISH or MIXED:	If METRIC:
Default: 0.00 in	Default: 0.0 mm
Min: - 20.00 in	Min: - 500.0 mm
Max: + 20.00 in	Max: + 500.0 mm

Parameter LC: Pivot to test-weight length. For weighbridges which do not have a pivot, enter zero.

```
- SC DATA SCROLL 3L-  
Pivot to test-weight  
length 000.00 In  
ENTER
```

Password: Service

If ENGLISH or MIXED:	If METRIC:
Default: 24.00 in	Default: 0 mm
Min: 0.00 in	Min: 0 mm
Max: 200.00 in	Max: 5000 mm

Parameter LF: Pivot to carriage height. For weighbridges which do not have a pivot, enter zero.

```
- SC DATA SCROLL 3M-  
Pivot to carriage  
height 000.00 In  
ENTER
```

Password: Service

If ENGLISH or MIXED:	If METRIC:
Default: 6.50 in	Default: 0 mm
Min: 0.00 in	Min: 0 mm
Max: 10.00 in	Max: 250 mm

Parameter LG: Carry roll to carriage height. For weighbridges which do not have a pivot, enter zero.

```
- SC DATA SCROLL 3N-  
Roll to carriage  
height 000.00 In  
ENTER
```

Password: Service

If ENGLISH or MIXED:

Default: 6.50 in
Min: 0.00 in
Max: 20.00 in

If METRIC:

Default: 0 mm
Min: 0 mm
Max: 250 mm

Enter the **number of load cells** of your weighbridge.

```
- SC DATA SCROLL 30-  
# of load cells  
0  
ENTER
```

Password: Service

Default: 1
Min: 1
Max: 6

4. Defining Dimensional Parameters of the Application

Parameter LD: Idler spacing in scale area. For better accuracy, average the distance between the idlers across the scale on both sides. Measure to within 0.032 inch or 1 mm with the numeric keys and press **ENTER**.

```
- SC DATA SCROLL 4-  
Idler spacing  
36.00 In  
ENTER
```

Password: Service

If ENGLISH or MIXED:

Default: 36.00 in
Min: 2.00 in
Max: 120.00 in

If METRIC:

Default: 1000 mm
Min: 50 mm
Max: 2500 mm

Enter the **angle of inclination** of the belt conveyor. If an inclination meter is connected to the scale, after this preliminary set up has been completed, enable the automatic angle detection in I/O definition (Menu 4) and calibrate the angle meter.

```
- SC DATA SCROLL 5 -  
Conveyor's angle  
0.0 Degrees  
ENTER +/-
```

Password: Service

Default: 0.0
Min: - 25.00°
Max: + 25.00°

5. Defining the Load Cell(s)

Enter the **load cell capacity** as it appears on the label placed on the load cell.

```
- SC DATA SCROLL 6 -  
Load cell capacity  
250 Lbs  
ENTER
```

Password: Service

If ENGLISH or MIXED:	If METRIC:
Default: 250.0 Lbs	Default: 100 kg
Min: 1 Lbs	Min: 1 kg
Max: 15000 Lbs	Max: 5000 kg

The sensitivity was entered when the belt scale code was entered. If other (0) was selected, enter the **load cell sensitivity** in mV/V as marked on the label of the load cell. Ramsey load cells are normally 2.000 or 3.000 mV/V.

```
- SC DATA SCROLL 7 -  
Load cell sens.  
3.000 mV/V  
ENTER
```

Password: Service

Default: 3.000 mV/V
Min: 0.500 mV/V
Max: 3.500 mV/V

Load cell resistance is entered on this screen. The resistance for the load cell has been recorded on the System Data Sheet in the front of your belt scale manual. (It is also stamped on the load cell cable.) Enter the ohms for the load cell. The number of scrolls depends on the number of load cells specified in scroll 30.

```
- SC DATA SCROLL 8A -  
Load cell #1 res  
350.000 Ohms  
ENTER
```

Password: Service

Default: 350 Ohms
Min: 10 Ohms
Max: 2000 Ohms

If # of Load Cells is 2 or more:

```
- SC DATA SCROLL 8B -  
Load cell #2 res  
350.000 Ohms  
ENTER
```

Password: Service

Same default and limits of load cell #1.

If # of Load Cells is 3 or more:

```
- SC DATA SCROLL 8C -  
Load cell #3 res  
350.000 Ohms  
ENTER
```

Password: Service

Same default and limits of load cell #1.

If # of Load Cells is 4 or more:

```
- SC DATA SCROLL 8D -  
Load cell #4 res  
350.000 Ohms  
ENTER
```

Password: Service

Same default and limits of load cell #1.

If # of Load Cells is 5 or more:

```
- SC DATA SCROLL 8E -  
Load cell #5 res  
350.000 Ohms  
ENTER
```

Password: Service

Same default and limits of load cell #1.

If # of Load Cells is 6:

```
- SC DATA SCROLL 8F -  
Load cell #6 res  
350.000 Ohms  
ENTER
```

Password: Service

Same default and limits of load cell #1.

6. Defining the Speed Input

The speed input screen allows the operator to select either the single speed sensor input (default value), the double speed sensor input (to provide extra safety against speed sensor failure) or a simulated value using an internal timer.

Simulation allows operation without a speed sensor. When simulated speed is selected, a conveyor running input is required (refer to the field wiring diagram).

NOTE: If speed is selected as the third line display, the line will be blank in RUN mode when simulated speed is selected.

```
- SC DATA SCROLL 9 -  
Speed input  
> single <  
CHOICE ENTER
```

Default: SINGLE
Selections: SINGLE, DUAL, SIMULATED

7. Setting the Dead Band

The dead band is a percentage of the scale capacity (rate) in which the rate is ignored (if any) and a zero rate is forced. Also totalization is frozen when rate is below dead band.

```
- SC DATA SCROLL 10-  
Zero Dead-Band Range  
0 %  
ENTER
```

Password: Service

Default: 0 %
Min: 0 %
Max: 5 %

8. Weights and Measures Mode (Only if Audit Trail Option is installed)

This scroll details certain parameters to conform with the approval agency.

```
- SC DATA SCROLL 11-  
W&M mode  
> NONE <  
CHOICE ENTER
```

Password: Service

Default: NONE
Selections: NONE,OIML

4.2.3 Calibration Data

The CAL DATA scroll allows the operator to enter or set parameters which relate to the calibration of the scale.

1. Defining the Calibration Mode

Select which simulated method of automatic calibration is to be used. The selected method is the only one displayed in the calibration section of Menu 1.

```
- CAL DATA SCROLL 1-  
Calibration mode:  
> R-CAL <  
CHOICE ENTER
```

Password: Service

Default: R-CAL
Selections: R-CAL, CHAIN, WEIGHTS

A. Detailing the R-CAL Parameters

This section only applies if R-CAL mode was selected as the preferred method. Enter the resistance in ohms of the R-cal resistor installed in your integrator. Default value installed is 165000 ohms. See the Data Sheet in front of this manual for exact resistance.

```
- CAL DATA SCROLL 2-  
R-CAL select.  
Res 165000 ohms  
ENTER
```

Password: Service

Default: 165000 Ohms
Min: 10 Ohms
Max: 1000000 Ohms

The system calculates the CALCON (Calibration Constant) based on the mechanical and electrical parameters entered in Scale Data. This menu is for reference only.

```
- CAL DATA SCROLL 3-  
R-CAL constant  
00.00  
MENU      RUN
```

B. Detailing the Chains Parameters

This section only applies if CHAINS mode was selected as the preferred method. Enter the weight per foot or meter of the chains that is used for calibration.

```
- CAL DATA SCROLL 4-  
Chain select.  
weight 00.000 Lb/Ft  
ENTER
```

Password: Service

If ENGLISH or MIXED:

Default: 0.000 Lbs/Ft
Min: 0.000 Lbs/Ft
Max: 1000.000 Lbs/Ft

If METRIC:

Default: 0.000 kg/m
Min: 0.000 kg/m
Max: 3000.000 kg/m

The system calculates the CALCON (Calibration Constant) based on the mechanical and electrical parameters entered in Scale Data. This menu is for reference only.

```
- CAL DATA SCROLL 5-  
CHAIN CAL constant  
00.00  
MENU      RUN
```

Password: Service

C. Detailing the Test Weight Parameters

This section only applies if TEST WEIGHTS mode was selected as the preferred method. Enter the weight of the test weights that are used for the calibration.

```
- CAL DATA SCROLL 6-  
Total test weight on  
scale 20.000 Lbs.  
ENTER
```

Password: Service

If ENGLISH or MIXED:

Default: 0.000 Lbs

Min: 0.000 Lbs

Max: Load cell size x no. of load cells

If METRIC:

Default: 0.000 kg

Min: 0.000 kg

Max: Load cell size x no. of load cells

The system calculates the CALCON (Calibration Constant) based on the mechanical and electrical parameters entered in Scale Data. This menu is for reference only.

```
- CAL DATA SCROLL 7-  
WEIGHT CAL constant  
00.00  
MENU      RUN
```

2. Entering a Calibration Interval (Only if COMM "A" option is installed)

If an optional COMM board is installed, the system can be programmed to prompt the operator when the next calibration is due. If this option is not desired, confirm the default 0 days interval, otherwise enter the number of days. The calibration date displayed in Scroll 9 is automatically updated whenever a calibration is performed. If a non zero value is entered, an alarm appears after the time is elapsed. The alarm can only be cleared after a calibration check is executed.

```
- CAL DATA SCROLL 8-  
Calibration interval  
365 Days  
ENTER
```

Password: Operator

Default: 0 Days

Min: 0 Days

Max: 365 Days

This scroll displays the date of the last calibration and the expected date of the next one, based on the entry in the previous screen.

```
- CAL DATA SCROLL 9-  
Calibration date  
Last:   MM-DD-YYYY  
Next:   MM-DD-YYYY
```

3. Entering Material Factors

The material factor is a number in percent which is used to correct the CALCON to the real value. Entering 0 makes the material factor INVALID.

```
- CAL DATA SCROLL 10-  
Material FACTOR  
00.00 %      R-Cal  
ENTER      +/- NEXT
```

Password: Service

Default: 0 %
Min: - 99.99 %
Max: + 99.99 %

The **NEXT** key scrolls between the R-Cal, Weights and Chains material factors. If they have not yet been measured, "INVALID" is displayed.

4. Defining the Calibration Test Duration

Zero and Span calibrations are more accurate if executed on an entire belt revolution or multiple of it. Press either **ACQUIRE** or **MANUAL**, **ACQUIRE** is the recommended selection. For **MANUAL**, see Step 7 below.

```
- CAL DATA SCROLL 11-  
Establish test  
duration  
ACQ  MANUAL
```

Select **ACQUIRE**. Acquire is the recommended selection.

A. Acquiring the Test Duration

When selecting **FULL**, use a 100 foot tape to measure the belt length to the nearest 0.1 foot. Reference a fixed point (an idler) on the conveyor when counting belt revolutions. See Section 2.5.1 for the recorded conveyor belt length.

The **PARTIAL** (belt length measurement) selection enables the operator to acquire test duration without the entire belt length measurement.

NOTE: This option should only be used when belt length exceeds 1000 feet.

```
ACQUIRE TEST DUR  
Choose belt length  
measurement method.  
FULL  PARTIAL
```

FULL is the recommended selection.

5. Full Test Duration Acquisition

If FULL is pressed, the operator is asked to enter the length of one belt revolution. Enter the length recorded in Section 2.5.1. Measure belt length to the nearest 0.1 feet.

```
Enter length of one
belt revolution.
Length 1000.0 Ft
ENTER ABORT
```

Password: Service

If ENGLISH or MIXED:

Default: 1000.0 Ft
Min: 1.0 Ft
Max: 10000.0 Ft

If METRIC:

Default: 200.0 m
Min: 0.5 m
Max: 3000 m

After the length of the belt has been entered, the system automatically moves to the following screen which prompts the operator to press **START** when the mark passes the reference point. Pressing **ABORT** returns the screen to Cal Data Scroll 11.

NOTE: The belt must be running at the maximum speed before executing this function. If not, the prescaler will be improperly calculated.

```
Start belt. Press
START when 1st mark
passes reference.
START ABORT
```

NOTE: If a clip detector is installed and clip detector mode is set to "AUTO" in I/O Definition Scroll, skip to Step 6.

When **START** is pressed, the system automatically moves to the next instructional screen. The operator presses **COUNT** each time the mark passes the reference point until minimum test load conditions are met (refer to the belt scale installation manual for minimum test level requirements). When the last revolution passes the mark, the operator must press **COUNT** followed by pressing **DONE**.

Pressing **ABORT** returns the screen to Cal Data Scroll 11.

```
Press COUNT each
time a mark passes.
00000 secs 000 revs
COUNT ABORT DONE
```

Pressing **ABORT** returns the screen to Cal Data Scroll 11.

When test duration is finished, the new values for length of belt and time are displayed. Press **CONTINUE**.

```
TEST DURATION
Length = 0000.0 Ft
Time = 000 sec
CONTINUE
```

6. Auto Count Belt Revolutions

If a clip detector is installed and clip detector mode in I/O Definition is set to "**AUTO**", the system automatically counts belt revolutions without the need for pressing the **COUNT** key. The two screens for Acquiring Test Duration are displayed as follows:

```
Start belt. Wait
until 1st mark
passes reference.
ABORT
```

When the mark passes, the system automatically moves to the next instructional screen. The system counts each time a mark passes the reference point until the operator presses the **DONE** key.

```
Press DONE when
ready.
0000 secs 000 revs
ABORT DONE
```

7. Partial Test Duration Acquisition

If **PARTIAL** is pressed, the operator is asked to enter the length between two marks on the belt.

Pressing **ABORT** returns the screen to Cal Data Scroll 11.

```
Enter length between
two marks on belt.
Length: 200.0 Ft
ENTER ABORT
```

Password: Service

If ENGLISH or MIXED:

Default: 200.0 Ft
Min: 1.0 Ft
Max: 10000.0 Ft

If METRIC:

Default: 50.0 m
Min: 0.5 m
Max: 3000.0 m

After the length of the belt has been entered, the system automatically moves to the following screen which prompts the operator to press **START** when the mark passes the reference point.

NOTE: The belt must be running at the maximum speed before executing this function. If not, the prescaler is improperly calculated.

Pressing **ABORT** returns the screen to Cal Data Scroll 11.

```
Start belt. Press
START when 1st mark
passes reference.
START ABORT
```

When **START** is pressed, the system automatically moves to the next instructional screen. The operator presses **COUNT** each time a mark passes the reference point until both marks have passed. Then press **DONE**.

Pressing **ABORT** returns the screen to Cal Data Scroll 11.

```
Press COUNT each
time a mark passes.
00000 secs 000 revs
COUNT ABORT DONE
```

NOTE: The **COUNT** key is not displayed if the clip detector option is in Auto mode.

When test duration is finished, the new values for length of belt and time are displayed. Press **CONTINUE**.

```
TEST DURATION
Length = 0000.0 Ft
Time = 000 sec
CONTINUE
```

8. Manual Entry of Test Duration

This procedure allows direct entry of parameters that would otherwise be generated by the acquire Test Duration modes. This menu is generally used when the operator cannot see the belt while standing at the front panel.

If **MANUAL** is pressed, the system prompts the operator to run the belt at its maximum speed. Then press **CONTINUE**.

Pressing **ABORT** returns the screen to Cal Data Scroll 11.

```
Start belt. Press
CONTINUE when belt
is at maximum speed.
ABORT CONTINUE
```

Password: Service

The operator is prompted to enter the length of one belt revolution.
Pressing **ABORT** returns the screen to Cal Data Scroll 11.

```
ENTER length of one
belt revolution.
Length 000.0 FT
ENTER ABORT
```

Password: Operator

If ENGLISH or MIXED:	If METRIC:
Default: 200.0 Ft	Default: 200.0 m
Min: 1.0 Ft	Min: 1.0 m
Max: 10000.0 Ft	Max: 10000.0 m

The number of belt revolutions to be timed is than entered.
Pressing **ABORT** returns the screen to Cal Data Scroll 11.

```
ENTER the number of
belt revolutions to
be timed 000 revs
ENTER ABORT
```

Default:	1
Min:	1
Max:	100

The next entry is the time per revolution.
Pressing **ABORT** returns the screen to Cal Data Scroll 11.

```
ENTER the time for
revolutions to pass
reference 000 sec
ENTER ABORT
```

Default:	30 sec
Min:	1 sec
Max:	16200 sec

When **ENTER** is pressed, the system times the belt travel according to the above entered parameters.

Pressing **ABORT** returns the screen to Cal Data Scroll 11.

```
Timing belt travel
000 sec

      ABORT
```

When test duration test is finished, the new values for length of belt and time are displayed. Press **CONTINUE**.

```
TEST DURATION
Length = 000.0 Ft
Time = 000 sec
      CONTINUE
```

9. Defining Auto Zero Tracking

A periodic auto zero procedure can be automatically executed by the system if the Auto Zero Tracking option is set to YES. If YES is selected, Auto Zero Tracking is enabled anytime the belt is running at a flow rate less than the range setting selected below.

```
- CAL DATA SCROLL 12-
Auto zero tracking
> Yes <
CHOICE  ENTER
```

Password: Operator

Default: No
Selections: Yes, No

The following scrolls are only visible if Auto Zero Tracking is enabled.

Define the range of action of the AZT with reference to the scale capacity (rate). A flow rate greater than the range setting deactivates AZT.

```
-CAL DATA SCROLL 12A-
Auto zero tracking
Range ±4.0 %
ENTER
```

Password: Operator

Default: ± 4 %
Min: ± 0 %
Max: ± 10 %

Define the maximum amount of zero error (with reference to the scale capacity) that AZT can automatically compensate.

```
-CAL DATA SCROLL 12B-  
Auto zero tracking  
Max Dev ±4.0 %  
ENTER
```

Password: Service

Default: ± 4 %
Min: ± 0 %
Max: ± 10 %

10. Entering the Speed Capacity

The user can **ENTER** the maximum speed capacity or **ACQ**uire it. To acquire the speed, run the belt at maximum speed and then press the **ACQ** key.

```
- CAL DATA SCROLL 13-  
Max speed capacity  
200.0 Fpm  
ENTER                    ACQ
```

Password: Service

If ENGLISH or MIXED:
Default: 200.0 Fpm
Min: 1.0 Fpm
Max: 2000.0 Fpm
If METRIC:
Default: 1.0 m/s
Min: 0.1 m/s
Max: 10 m/s

The maximum speed capacity is used to scale the current output when used to monitor the speed, and to allow entering the speed alarms in %.

11. Defining the Number of Calibrations

This screen allows the operator to specify the number of calibrations to be defined. If a number higher than 1 is entered, the digital inputs for calibration selection can be defined.

```
- CAL DATA SCROLL 14-  
Number of calib.  
1  
ENTER
```

Password: Service

Default: 1
Min: 1
Max: 10

4.3 MAIN MENU 3

Main Menu 3 is used for protecting and unprotecting the system using passwords, and to perform diagnostic and test functions. The diagnostic functions can only be operated after removing all password protection, and should only be used by experienced technical personnel. Most test functions are not password protected.

```
- MAIN MENU 3 -  
Press MENU for more  
PROT   DIAG   TEST
```

The PROTECTION menu only becomes visible after passwords have been defined (see the Diagnostics Menu).

4.3.1 Changing the Protection Level

The Micro-Tech 2000 has three protection levels to which specific passwords are related.

The protection levels and the passwords are defined using the following scheme:

Protection	Password	Status
NONE	SERVICE	The system is totally unprotected, all data can be read or changed.
LIMITED	OPERATOR	Operator functions and data are unprotected. All setup and calibration data are protected except zero calibrate.
PROTECTED		The system is totally protected, process data can be read, no change allowed.

A **SERVICE** password is required to access the **NONE** level. An **OPERATOR** or a **SERVICE** password is required to access the **LIMITED** level.

Use the **NONE** key to access the **NONE** protection level. If the current level is not already **NONE**, the **SERVICE** password is required.

Use the **LTD** key to access the limited protection level. If the system is in level **NONE**, change is immediate. If it is in **PROT** level, the **SERVICE** or **OPERATOR** password is required. Use the **PROT** key to access the protected level. No password is required.

```
- PROTECTION LEVEL -  
> NONE <  
  
NONE   LTD   PROT
```

Default: NONE

Selections: NONE, LIMITED, PROTECTED

Password: from NONE to LTD or PROT: not required

from LTD to PROT:	not required
from LTD to NONE:	SERVICE
from PROT to NONE:	SERVICE
from PROT to LTD:	OPERATOR or SERVICE

Pressing the soft key gives entry into desired level. Going from a low level to a higher level forces the password entry.

1. On Line Procedure for Changing Protection Level

The protection level can be temporarily changed by entering a password "on the fly" during normal operation. When the operator tries to enter a variable or select a function which is password protected, and the password is installed, the following screen is displayed.

```
- SYSTEM PROTECTED -  
PLEASE ENTER  
PASSWORD _____  
ENTER
```

The operator can enter either the OPERATOR or the SERVICE passwords. However, if the operator enters the OPERATOR password and the variable or function requires the SERVICE password instead, the access is denied and the following screen is displayed.

```
- SYSTEM PROTECTED -  
PLEASE ENTER SERVICE  
PASSWORD _____  
ENTER
```

If the operator fails to enter the correct password, the following screen appears.

```
- SYSTEM PROTECTED -  
INVALID PASSWORD  
ACCESS DENIED  
RETURN
```

Pressing **RETURN** returns the program to the previous function. If the operator enters the correct password, the previous screen appears and access is allowed.

When the protection level is changed using the on line procedure, the system automatically returns to protected status if no keyboard entries are made within 60 seconds.

4.3.2 Diagnostics

1. A/D Raw Data

Diagnostic Scroll 1 shows the raw data from the A/D converter of the integrator (A/D gross) and the net value after the zero constant has been subtracted. The range of the A/D converter is from 0 to 131070 numbers.

```
-DIAGNOST. SCROLL 1-  
  
A/D gross  00000  
A/D net    0000
```

2. Readout Load Cell mV

The system displays the mV output of the load cell. The reading must be positive and must increase when the load increases.

```
-DIAGNOST. SCROLL 2-  
Weight on load cell  
0.000 mV  
  
CALIB
```

Password: Service

If **CALIB** is pressed, the next two scrolls are displayed and can be used to fine tune the readout of mV/V.

```
-DIAGNOST. SCROLL 2A  
Loadcell output zero  
0000000 A/D counts  
ENTER
```

Password: Service

Default: 15
Min: 0
Max: 10000

```
-DIAGNOST. SCROLL 2B  
Loadcell output span  
0000000  
ENTER
```

Password: Service

Default: 3497
Min: 0
Max: 30000

3. Change Prescaler

The prescaler is a number which is used to divide the incoming frequency of the speed sensor(s) to achieve a usable input frequency of approximately 30 Hz. The prescaler is automatically calculated and should never be altered by the user. However, a direct entry has been made possible for quick replacement of the integrator.

```
-DIAGNOST. SCROLL 3-  
Prescale 00000  
00000.0 pls/min  
ENTER          CALIB
```

Password: Service

Default: 10
Min: 1
Max: 100

If **CALIB** is pressed, the following screens appear.

```
-DIAGNOST. SCROLL 3A  
Test duration total  
pulses 0000000  
ENTER
```

Password: Service

Default: 900
Min: 1
Max: 1000000

```
-DIAGNOST. SCROLL 3B  
Test duration total  
length 00000.0 ft  
ENTER
```

Password: Service

If **ENGLISH** or **MIXED**:

Default: 200 feet
Min: 1 feet
Max: 100000 feet

If **METRIC**:

Default: 200 m
Min: 1 m
Max: 100000 m

4. Change Passwords

The password can be changed by entering a new one. The user can enter up to eight characters (numeric keys entries). The entered numbers are not echoed on the screen. Pressing just the ENTER key removes the password.

```
-DIAGNOST. SCROLL 4-  
ENTER SERVICE  
PASSWORD      *****  
ENTER
```

Password: Service

Default: No password

After the password has been entered, the system asks for confirmation. This prevents losing access control due to a typing mistake while entering passwords.

```
-DIAGNOST. SCROLL 4-  
REENTER SERVICE  
PASSWORD      *****  
ENTER
```

If the password entered the second time matches the first, the following message confirms the entry.

```
-DIAGNOST. SCROLL 4-  
NEW PASSWORD  
ACQUIRED  
RETURN
```

If the two passwords do not match, the system does not accept the new password.

```
-DIAGNOST. SCROLL 4-  
INVALID PASSWORD  
  
RETURN
```

```
-DIAGNOST. SCROLL 5-  
ENTER OPERATOR  
PASSWORD      *****  
MENU ENTER
```

Password: Operator

Default: No password

The OPERATOR password is double checked similarly to the service one. It is strongly suggested to write down the password and preserve a copy in a safe place. If the password is forgotten, refer to Section 4.3.7 to remove a forgotten password.

5. Display Software Version

The software version is displayed for reference only.

```
-DIAGNOST. SCROLL 6A-  
Main software  
version:  
33.XX.XX.XX-B1
```

6. Setup Date and Time

This section only applies if a COMM board is installed. The user can set the current date and time. A battery operated clock calendar then maintains time and date even if power is removed. Day, Month, and Year are entered in sequence.

```
-DIAGNOST. SCROLL 7-  
Date: DD-MM-YYYY  
DAY: DD  
ENTER
```

Password: Service

Default: 00-00-0000
Min: 01-01-0000
Max: 31-12-2096

Time is entered in a similar way. The AM/PM key is used when time is in the English mode. See Display Scroll 7 in Main Menu 2.

```
-DIAGNOST. SCROLL 8-  
Time: HH:MM  
HOURS: HH  
ENTER AM/PM
```

Default: 00.00 24 hour am/pm
Min: 00.00 01.00
Max: 23:59 12:59

7. Check Hardware Configuration

The system automatically recognizes when optional boards are installed. The following scrolls are used to show the configuration. Remember that when a board is acknowledged, the related information stays in memory even if the board is removed, until the operator deletes it by responding YES to the message shown at power on.

The following screen is displayed for each board installed in each slot.

-DIAGNOST. SCROLL 9-
Board type slot #1

BOARD TYPE

-DIAGNOST. SCROLL 10
Board type slot #2

BOARD TYPE

-DIAGNOST. SCROLL 11
Board type slot #3

BOARD TYPE

-DIAGNOST. SCROLL 12
Board type slot #4

BOARD TYPE

-DIAGNOST. SCROLL 13
Board type slot #5

BOARD TYPE

-DIAGNOST. SCROLL 14
Board type slot #6

BOARD TYPE

BOARD TYPE can be:

- Dig I/O 16in/4out
- Dig I/O 16out/4in

Optional digital input output board.

- #16 Optocoupled Digital Inputs
- #4 Optocoupled digital outputs

Optional digital input output board.

- #4 Optocoupled Digital Inputs
- #16 Optocoupled digital outputs

- Load Out 16in/4in	Optional digital input output board dedicated to the Load Out. - #16 Optocoupled digital inputs
- Load Out 16out/4in	Optional digital input output board dedicated to the Load Out. - #4 Optocoupled digital inputs
- Analog I/O	Optional analog input output board. - #16 Optocoupled digital inputs
- Current Out	Optional current output board. - #2 Current outputs - #2 Voltage inputs
- Communication A	Serial communication board (RS232, RS485)
- Communication B	Allen-Bradley Remote I/O PROFIBUS-DP

8. Force Cold Start

This scroll is used to force a cold start of the instrument in the event the software becomes corrupted. Factory default constants will be installed when the instrument restarts; all field entry data will be replaced.

```

-DIAGNOST.SCROLL 15-
Force cold start

ENTER
```

4.3.3 Tests

1. Lamp Test

Press **START** to begin a Lamp Test of the integrator. All LED's and digits of the display blink for a number of seconds.

```

- TEST SCROLL 1 -
LAMP TEST

START
```

2. Self Test of the Unit

The system can perform some internal test functions, which can be used to detect malfunctions to the hardware devices.

```
- TEST SCROLL 2 -  
Internal test of  
microprocessor.  
START
```

Password: Service

After **START** is pressed, the following screens are displayed in sequence.

```
- TEST SCROLL 2A -  
Testing ROM  
Test PASSED
```

```
- TEST SCROLL 2B -  
Testing RAM  
Test PASSED
```

The message "Test PASSED" is displayed if the test runs correctly. If something wrong is detected, then the message "Test FAILED" is displayed, and the soft key **CONTINUE** is shown. The operator has to press the key to go on to the next test.

NOTE: Test 2C requires a hardware jumper to be installed between serial in and serial out pins of the mother board. Since the jumper is not normally in place, a "Test FAILED" message at the end of Test 2C is normally displayed.

3. Test Digital Inputs

The next screen is used to check the digital input circuitry. The display shows a 1 if the specific input is closed, 0 if open. If more digital I/O boards are installed, the **NEXT** soft key appears, allowing the operator to scroll between boards.

```
- TEST SCROLL 3 -  
Dig input test  
Slot#0      ----00--  
          NEXT
```

Slots are numbered 1 to 6, slot 0 is the mother board. 'Digit' (displayed instead of 'slot#') identifies the four Digitizer's inputs. Inputs are shown from right to left. If a board has 16 inputs, two screens are used to show the first and the second half, the lower half is shown first.

4. Test Digital Outputs

This test shows the status of each digital output and allows the operator to force the output for testing purposes. The output, when forced, stays on until

the **CLEAR** soft key is pressed or the Run Menu is entered. If an output is forced and the scroll key is used for reaching some other menu, the output stays in the forced status until **RUN** is pressed. This allows the operator to check inputs while outputs are still in the forced status.

```
- TEST SCROLL 4 -  
Dig output test  
output # 1 : ON/OFF  
ENTER      ON/OFF
```

Password: Service

To force an output, enter the desired number followed by **ENTER**. Then use the **ON/OFF** key to force it to the **ON** or **OFF** status. After the output has been forced, the **CLEAR** soft key appears in the middle position.

Slots are numbered 1 to 6, slot 0 is the mother board.

WARNING

**FORCING THE DIGITAL OUTPUTS MAY CAUSE MACHINERY TO START.
AFTER THE USER TRIES TO FORCE AN OUTPUT, THE FOLLOWING
MESSAGE WILL BE DISPLAYED.**

```
WARNING  
EQUIPMENT MAY START  
  
CONTINUE      ABORT
```

**IF THE USER PRESSES CONTINUE, BE AWARE THE ACTION MAY CAUSE DAMAGE
OR INJURY. IF THE USER PRESSES ABORT, THE SYSTEM WILL RETURN TO THE
PREVIOUS SCROLL.**

5. Test Current Outputs

This section only applies if a current output board is detected. The integrator can have one or two current output channels.

```
- TEST SCROLL 5 -  
Current output #1  
should be 00.0 mA  
ENTER CLEAR
```

Password: Service

Default: 0.0 mA
Min: 0.0 mA
Max: 20.0 mA

To force the output, enter the desired number of milliamps and press **ENTER**. Press **CLEAR** to free the mA channel.

If the board has two channels, the following screen is shown.

```
- TEST SCROLL 6 -  
Current output #2  
should be 00.0 mA  
ENTER CLEAR
```

Password: Service

Default: 0.0 mA
Min: 0.0 mA
Max: 20.0 mA

6. Test Current Inputs

The following screen is displayed only if an analog input board is detected, and shows the status of each analog input channel.

```
- TEST SCROLL 7 -  
Current input  
#1 00.0 V  
#2 00.0 V
```

7. Test Communication A

The following screen allows checking the installed serial lines. Maximum line number is 3; the first is used to interface the Digitizer, the others can be used for printing or high level communications. **Digit** soft key identifies the first dedicated line, "**Port 1**" and "**Port 2**" soft keys are shown only if a second and third COMM board is detected.

```
- TEST SCROLL 8 -  
Test communication A  
  
DIGIT PORT 1 PORT 2
```

Password: Service

By pressing the **DIGIT**, **PORT 1** or the **PORT 2** soft key, the test is initiated. A test pattern is sent out on the TX output and read on the RX input. If the test fails, the message "Test Failed" is shown; otherwise, the message "Test Passed" is displayed.

NOTE: This test requires a hardware jumper to be installed between terminals TB5-8 (RX) and TB5-9 (TX) on the communication board.

8. Test Communication B

This test is similar to the previous one but works for the field bus version of the communication board.

```
- TEST SCROLL 9 -
Test communication B
START
```

Password: Service

9. Test BCD Input Board

If an optional BCD input card is detected, the following screen appears. The test is similar to the digital input test.

```
- TEST SCROLL 10 -
BCD Input test
0000
```

10. Test BCD Output Board

The following test is displayed if an optional BCD output board is detected.

```
- TEST SCROLL 11 -
BCD Output test
0000
ENTER CLEAR
```

Default: 0
Min: 0
Max: 9999 or 7999 if parity check enabled

To force the outputs, enter a number followed by **ENTER**. The **CLEAR** key appears indicating that the output is being forced to a value. By pressing **CLEAR**, the output is freed.

11. Test the CPU Serial Line

```
- TEST SCROLL 12 -
Test CPU serial line
START
```

Password: Service

If **START** is pressed, the system performs a test of the serial line of the CPU board.

NOTE: The CPU serial line is not implemented in the current hardware, therefore the normal response is TEST FAILED.

12. Test the Keyboard and Switches

```
- TEST SCROLL 13 -  
Keyboard + switches  
Key: _____  
Switches: 00000000
```

Press the **RUN** key twice to exit. All other keys, including **MENU**, are displayed but not executed.

4.4 MAIN MENU 4

Main Menu 4 is dedicated to the definition of the input output (I/O) and alarms.

```
- MAIN MENU 4 -  
Press MENU for more  
I/O ALARMS  
DEFINE DEFINE
```

4.4.1 I/O Definition

The input output section of the system is fully configurable. All inputs and outputs are conventionally numbered and can be assigned to physical input and output terminals depending on the needs. The following section explains how to configure I/O. However, the standard configuration as provided by the factory is normally satisfactory.

1. Define Current Outputs

The following menus are shown for configuring the current output(s). Use the **CHOICE** key to change the variable and the **ENTER** key to confirm. The **NEXT** key allows the operator to set up to four (4) current outputs if installed.

```
- I/O DEF SCROLL 1 -  
Current Output define  
#1 > Rate <  
CHOICES ENTER NEXT
```

Password: Service

Default: (1st) RATE, (2nd) LOAD
Selections: OFF, RATE, LOAD, SPEED

If the selection of the previous screen is not **OFF**, the operator can set up the range, delay and damping of the current output. The range is selectable between the standard 0 to 20 mA and 4 to 20 mA both in direct and reverse mode. Select 0-20 or 4-20 if an increase in current is desired for any increase of the variable. Select 20-0 or 20-4 if a decrease of current is desired for any increase of the variable.

```
- I/O DEF SCROLL 1A-  
Current out range  
#1 > 4-20 mA <  
CHOICES ENTER NEXT
```

Password: Service

Default: (1st) 4-20 mA, (2nd) 4-20 mA, (3rd) 4-20 mA, (4th) 4-20 mA
Selections: 0-20 mA, 4-20 mA, 20-0 mA, 20-4 mA

Each current output can be delayed. This is typically needed in blending systems, to correct transport time differences. The delay can be set either in

time or in length of belt travel. Belt travel is suggested for variable speed applications. Use the T/L soft key to switch between time and length.

```
- I/O DEF SCROLL 1B-  
Current out delay      Password: Service  
#1  0  sec  
ENTER   T/L   NEXT
```

Default: (1st) 0 sec, (2nd) 0 sec, (3rd) 0 sec, (4th) 0 sec
If TIME:

Min: 0 sec
Max: 300 sec

If LENGTH:

English Min: (1st) 0 Ft, (2nd) 0 Ft, (3rd) 0 Ft, (4th) 0 Ft
Max: 10000 Ft
Metric Min: 0 M
Max: 300 M

A damping factor can also be selected for each current channel. The damping factor is the time for the output to stabilize after a step change. This damping only affects the current output, not the displayed variable, which has a separate damping factor, selectable in Main Menu 2, Display.

```
- I/O DEF SCROLL 1C-  
Current out damping    Password: Operator  
#1  4   
ENTER   NEXT
```

Default: (1st) 4 sec, (2nd) 4 sec, (3rd) 4 sec, (4th) 4 sec
Min: 0 sec
Max: 400 sec

UP and **DOWN** arrows move between range, delay and damping. **NEXT** moves to the next current output.

2. Define Analog Inputs

If an analog input board is installed, the following screens are displayed. Analog inputs can be used for measuring the moisture of the material or conveyor angle of inclination.

Moisture compensation is performed on the belt loading, and affects both rate and totals. Only during material calibration with material is moisture compensation suspended, so that the totalized quantity can be directly compared to the weight obtained on a static scale. The moisture compensation is executed before adding to total.

Angle compensation dynamically adjusts span when conveyor inclination changes. Use the **CHOICES** key to select the action of the analog input, use **ENTER** to confirm, use **CALIB** to calibrate the analog input signal.

```
- I/O DEF SCROLL 2 -  
Analog Input #1 def.  
> Inclination <  
CHOICES ENTER CALIB
```

Password: Service

Default: OFF
Selections: OFF, INCLIN(ATION), MOISTURE

```
- I/O DEF SCROLL 3 -  
Analog Input #2 def.  
> Moisture <  
CHOICES ENTER CALIB
```

Password: Service

Default: OFF
Selections: OFF, INCLIN(ATION), MOISTURE

A. Setup Moisture Compensation Input

If an analog input has been programmed for reading the moisture signal and **CALIB** was pressed, the following screens appear. The user can calibrate the input signal by entering the equivalence between percent of moisture and voltage on two points. Use the **%Moist** key to enter the percent of moisture, use the **volt** key to enter the corresponding number of volts, and confirm with **ENTER**.

```
- I/O DEF SCROLL 2A-  
Moisture input calibr.  
0.0 %M = 2.0 V  
ENTER %Moist Volt
```

Password: Service

Default: 0.0 % 0.0 V
Min: 0.0 % 2.0 V
Max: 20.0 % 2.5 V

Do the same with the second point shown below.

```
- I/O DEF SCROLL 2B-  
Moisture input calibr.  
20.0 %M = 5.0 V  
ENTER %Moist Volt
```

Password: Service

Default:	12.0 %	5.0 V
Min:	1.0 %	1.0 V
Max:	20.0 %	5.0 V

B. Setup Inclination Compensation Input

If an analog input has been programmed for reading the angle signal and **CALIB** was pressed, the following screens appear. The user can calibrate the input signal by entering the number of degrees corresponding to the minimum signal (0 mA or 4 mA) and the number of degrees corresponding to the maximum signal (20 mA). Use the +/- key to enter negative numbers, and confirm with **ENTER**.

```

- I/O DEF SCROLL 3A-
Conveyor low posit
00.0 Degrees
ENTER      +/-
  
```

Password: Service

Default:	0.0 Degrees
Min:	- 25 Degrees
Max:	+ 25 Degrees

```

- I/O DEF SCROLL 3B-
Conveyor high posit
00.0 Degrees
ENTER      +/-
  
```

Password: Service

Default:	0.0 Degrees
Min:	- 25 Degrees
Max:	+ 25 Degrees

3. Define Digital Inputs

Digital inputs can be programmed. The following screen shows one logical function per time, and allows the user to assign it to a physical input. The **NEXT** key scrolls between the logical functions. The **NC/NO** key selects the Normally Open (NO) or Normally Closed (NC) status of the input. Normally Open means the input is inactive when disconnected. To program a function, scroll with **NEXT** until the function is displayed, then enter the physical input number and confirm with **ENTER**, finally scroll with **NC/NO** until the desired mode is displayed. By assigning a function to 0, the function is disabled.

```

- I/O DEF SCROLL 4 -
Dig. Input def.
Ext Alarm 1   0 NC
ENTER  NC/NO  NEXT
  
```

Password: Service

The following table shows the available logical selections that can be assigned to any available physical input. Default inputs can be reassigned to any physical input if desired. External alarms 1, 2 and 3 can be assigned to logical functions not on the list.

Logical selections should not be reassigned after the physical inputs have been wired.

CAUTION

LOGICAL INPUTS RETURN TO THE DEFAULT IF THE INTEGRATOR IS COLD STARTED.

<u>Selections:</u>	<u>Default:</u>	
External alarm 1	0 NO	0 = function disabled
External alarm 2	0 NO	
External alarm 3	0 NO	
Print	0 NO	(Only if COMM installed & set to printer)
Belt Running (Conveyor run)	3 NC	
Reset Totals	0 NO	
Reset Alarms	0 NO	
Auto Zero	0 NO	(Only if AZT enabled)
Clip Detector	0 NO	
Batch Start	0 NO	(Only if Load Out installed)
Batch Stop	0 NO	(Only if Load Out installed)
Batch Standby	0 NO	(Only if Load Out installed)

One non assignable belt speed input and three assignable inputs are standard on the mother board.

MOTHER BOARD INPUTS

PHYSICAL INPUT NUMBER	ASSIGNED FUNCTION	FIELD MOUNT	PANEL MOUNT
1	BELT SPEED INPUT	TB9 2, 4 & 5	TB2 1, 2 & 3
2	_____	TB8 13 & 14	TB2 5 & 7
3	_____	TB8 11 & 12	TB2 8 & 10
4	_____	TB8 9 & 10	TB2 9 & 10

Additional assignable logical inputs from the above table can be selected by adding optional I/O boards. Available options are 4in/16out, 16in/4out or 20in/20out by adding both boards.

PHYSICAL INPUT NUMBER	ASSIGNED FUNCTION	DIGITAL INPUT/OUTPUT BOARD INPUTS		
		4IN/16OUT ONLY	16IN/4OUT ONLY	4IN/16OUT AND 16IN/4OUT
5	_____	J15 - 2	J16 - 17	J15 - 2
6	_____	J15 - 15	J16 - 5	J15 - 15
7	_____	J15 - 3	J16 - 18	J15 - 3
8	_____	J15 - 16	J16 - 6	J15 - 16
9	_____		J16 - 19	J16 - 17
10	_____		J16 - 7	J16 - 5
11	_____		J16 - 20	J16 - 18
12	_____		J16 - 8	J16 - 6
13	_____		J16 - 21	J16 - 19
14	_____		J16 - 9	J16 - 7
15	_____		J16 - 22	J16 - 20
16	_____		J16 - 10	J16 - 8
17	_____		J16 - 23	J16 - 21
18	_____		J16 - 11	J16 - 9
19	_____		J16 - 24	J16 - 22
20	_____		J16 - 12	J16 - 10
21	_____			J16 - 23
22	_____			J16 - 11
23	_____			J16 - 24
24	_____			J16 - 12

WARNING

CHANGING THE DEFINITION OF THE DIGITAL INPUTS MAY CAUSE MACHINERY TO START. AFTER THE USER TRIES TO CHANGE A DEFINITION, THE FOLLOWING MESSAGE IS DISPLAYED.

WARNING	
EQUIPMENT MAY START	
CONTINUE	ABORT

IF THE USER PRESSES CONTINUE, BE AWARE THE ACTION MAY CAUSE DAMAGE OR INJURY. IF THE USER PRESSES ABORT, THE SYSTEM WILL RETURN TO THE PREVIOUS SCROLL.

4. Define Digital Outputs

Digital outputs can be programmed. The following screen shows one logical function per time, and allows the user to assign it to a physical output. The **NEXT** key scrolls between the logical functions. The **NC/NO** key selects the Normally Open (NO) or Normally Closed (NC) status of the output. Normally Open means the output is not energized in normal conditions. To program a function, scroll with **NEXT** until the function is displayed, then enter the number of the physical output and confirm with **ENTER**, finally scroll with **NC/NO** until the desired mode is displayed. By assigning a function to 0, the function is disabled.

```

- I/O DEF SCROLL 5 -
Dig. Output def.
Alarm: 0  NC
ENTER  NC/NO  NEXT

```

Password: Service

The following table shows the available logical selections that can be assigned to any available physical output. Typical field wiring drawings and customer specific field wiring drawings show Ready defaulted to #1 NC, Alarm defaulted to #2 NC and Totalizer (remote counter) defaulted to #3 NO. Default selections can be reassigned to any physical output if desired.

Logical selections should not be reassigned after the physical outputs have been wired.

CAUTION

LOGICAL SELECTIONS RETURN TO THE DEFAULT IF THE FEEDER CONTROLLER IS COLD STARTED.

<u>Selections</u>	<u>Default</u>	
Alarm	2 NC	
Shut down	0 NO	
Ready	1 NC	
High Load	0 NO	(Only if Load Alarm enabled)
Low Load	0 NO	(Only if Load Alarm enabled)
High Rate	0 NO	(Only if Rate Alarm enabled)
Low Rate	0 NO	(Only if Rate Alarm enabled)
High Speed	0 NO	(Only if Speed Alarm enabled)
Low Speed	0 NO	(Only if Speed Alarm enabled)
Totalizer	3 NO	
Batch Preset	0 NO	(Only if Load Out installed)
Batch	0 NO	(Only if Load Out installed)
Print Ready	0 NO	(Only if W & M selected)
Load WTS (weights)	0 NO	

One non assignable Fault output and three assignable outputs are standard on the mother board.

MOTHER BOARD OUTPUTS

<u>PHYSICAL OUTPUT NUMBER</u>	<u>ASSIGNED FUNCTION</u>	<u>FIELD MOUNT</u>	<u>PANEL MOUNT</u>
	Fault Output	TB8 1 & 2	TB2 15 & 16
1	_____	TB8 7 & 8	TB2 12 & 16
2	_____	TB8 5 & 6	TB2 13 & 16
3	_____	TB8 3 & 4	TB2 14 & 16

Additional assignable logical selections from the above table can be selected by adding optional I/O boards. Available options are 4in/16out, 16in/4out or 20in/20out by adding both boards.

PHYSICAL OUTPUT NUMBER	ASSIGNED FUNCTION	DIGITAL INPUT/OUTPUT BOARD OUTPUTS INSTALLED OPTIONS		
		4IN/16OUT ONLY	16IN/4OUT ONLY	4IN/16OUT AND 16IN/4OUT
4	_____	J15-17	J16 - 2	J16 - 2
5	_____	J15 - 5	J16 - 15	J16 - 15
6	_____	J15 - 18	J16 - 3	J16 - 3
7	_____	J15 - 6	J16 - 16	J16 - 16
8	_____	J15 - 19		J15 - 17
9	_____	J15 - 7		J15 - 5
10	_____	J15 - 20		J15 - 18
11	_____	J15 - 8		J15 - 6
12	_____	J15 - 21		J15 - 19
13	_____	J15 - 9		J15 - 7
14	_____	J15 - 22		J15 - 20
15	_____	J15 - 10		J15 - 8
16	_____	J15 - 23		J15 - 21
17	_____	J15 - 11		J15 - 9
18	_____	J15 - 24		J15 - 22
19	_____	J15 - 12		J15 - 10
20	_____			J15 - 23
21	_____			J15 - 11
22	_____			J15 - 24
23	_____			J15 - 12

WARNING

CHANGING THE DEFINITION OF THE DIGITAL OUTPUTS MAY CAUSE MACHINERY TO START. AFTER THE USER TRIES TO CHANGE A DEFINITION, THE FOLLOWING MESSAGE IS DISPLAYED.

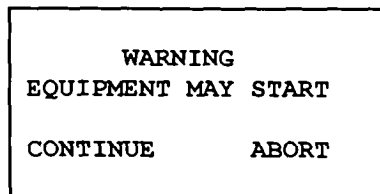

IF THE USER PRESSES CONTINUE, BE AWARE THE ACTION MAY CAUSE DAMAGE OR INJURY. IF THE USER PRESSES ABORT, THE SYSTEM WILL RETURN TO THE PREVIOUS SCROLL.

5. Define Remote Totalizer Output

If the TOTALIZER output function is assigned to an output, the following screens allow the user to set up related parameters. Set the divider according to the maximum rate the scale will run. The divider is entered in totalization units (T.U.). The pulse frequency generated in normal conditions should not

exceed 10 Hz. Higher frequencies are possible, however they do not improve accuracy.

```
- I/O DEF SCROLL 6 -  
Remote counter div.  
1  
ENTER
```

Password: Service

Default: 1
Min: 0.01
Max: 100

Enter the pulse width in seconds of the totalizer. A higher pulse width limits the maximum frequency. The default 0.1 sec is recommended for frequencies lower than 5 Hz.

```
- I/O DEF SCROLL 7 -  
Remote counter pulse  
width 0.100 sec  
ENTER
```

Password: Service

Default: 0.1 sec
Min: 0.005 sec
Max: 1 sec

6. Define BCD Output Data

If an optional load out board is installed, the user can select the related variable.

```
- I/O DEF SCROLL 8 -  
BCD Output variable  
> Rate <  
CHOICES ENTER
```

Password: Service

Default: OFF
Selections: OFF, RATE, LOAD, SPEED

If a selection other than OFF is made, the following screens allow the user to define the polarity and the parity check of the BCD output. The polarity selection reverses the signals from NO to NC and vice versa. If a parity criterium is selected, the most significant bit of the BCD output is used for parity check.

4.4.2 Alarms Definition

The alarms of the Micro-Tech 2000 can be programmed. Process alarms such as low and high rate can be set to the desired range. In addition, all alarms can be defined to be:

ALARM When an alarm occurs, the front panel ALARM status indicator illuminates. An ALARM message flashes in the lower, right hand RUN display. Pressing ALARM displays the alarm. Time and date are also displayed if the optional COMM board is installed.

Pressing RESET clears the alarm message if the alarm parameter has cleared. If the alarm parameter has not cleared, the message "ACK" appears when RESET is pressed. When the alarm parameter clears, the alarm indication clears.

Pressing RUN at any time returns the operator to the RUN menu.

Alarms can be automatically printed if the print option is enabled.

SHUT DOWN The alarm handler operates as above except the READY status indicator goes off and the SHUTDOWN physical output changes state at the same time as the ALARM status indicator comes on.

In the I/O definition scroll, alarm and ready can be assigned to N/C or N/O physical outputs. The output activates and deactivates at the same time as the front panel status indicators.

NONE Alarm is deactivated.

1. Define Rate Alarm

Use the **CHOICE** key to turn on or off the rate alarm. Confirm with **ENTER**.

```
- ALARM SCROLL 1 -  
Rate Alarm  
> NO <  
CHOICE          ENTER
```

Password: Operator

Default: NO
Selections: YES, NO

If the selection in the previous screen was YES, enter the low and high setpoints for the alarm. Also enter the desired delay time before the alarm is monitored. The **UNITS** key allows the user to specify the setpoints in engineering units. The % key selects setpoints in percent. The **SET/DLY** switches between the setpoint and the delay time.

```
- ALARM SCROLL 1A -  
Low rate set  
 10 %    105 sec  
ENTER SET/DELAY UNITS/%
```

Password: Operator

```
- I/O DEF SCROLL 8A-  
BCD Output polarity  
> Positive <  
CHOICES ENTER
```

Password: Service

Default: NEGATIVE
Selections: POSITIVE, NEGATIVE

```
- I/O DEF SCROLL 8B-  
BCD Output parity  
> Yes <  
CHOICES ENTER
```

Password: Service

Default: NO
Selections: NO, YES

7. Define BCD Input Data

If an optional load out input board is installed, the following screens allow the user to define the related variable and the polarity of the signals.

```
- I/O DEF SCROLL 9 -  
BCD Input variable  
> Load out setpoint <  
CHOICES ENTER
```

Password: Service

Default: OFF
Selections: OFF, BATCH PRE-ACT, BATCH SETPOINT

Only if BCD input is not set to OFF:

```
- I/O DEF SCROLL 9A-  
BCD input polarity  
> Positive <  
CHOICES ENTER
```

Password: Service

Default: NEGATIVE
Selections: NEGATIVE, POSITIVE

8. Clip Detector Option

The clip detector option reduces flow rate errors on light loaded belts caused by conveyor belt weight variances. Turning on Auto Zero Tracking in the Cal Data Scroll enables the clip detector. The clip detector is normally a proximity

switch that senses a metal target attached to the belt. In manual mode, the clip detector freezes the flow rate when the clip is detected and maintains it frozen for the programmed length. Totalization is not affected. In automatic, the Integrator automatically detects tare variations and compensates for them.

If the clip detector is assigned to one digital I/O input, the following screens appear.

- I/O DEF SCROLL 10- Clip detector mode <u>MANUAL</u> CHOICE ENTER	Password: Service
---	-------------------

Default: MANUAL
Choices: MANUAL, AUTO

In the **MANUAL** mode, the user must enter the length of belt which is affected by the belt splice. The system freezes the belt loading when the clip is detected and maintains it frozen until the specified belt length has passed.

- I/O DEF SCROLL 10A- Clip detect length <u>00.00 ft</u> ENTER	Password: Service
---	-------------------

If ENGLISH or MIXED:

Default:	1.0 Ft
Min:	0.5 Ft
Max:	10 Ft

If METRIC:

Default:	0.30 m
Min:	0.10 m
Max:	3.00 m

If the **AUTO** mode is selected, the system automatically detects belt weight variations and compensates for them. The Auto Zero Tracking then stores in memory a table of tare values which are used to compensate the tare variations point by point. In addition, when the Acquire Test Duration is run in the **ACQ FULL** mode, the **COUNT** key is not displayed because the system automatically counts the clip detector pulses. (For proper operation, there can only be one clip used for the entire belt length.)

9. Define Load WTS (Weights)

This feature activates a lowering/lifting mechanism for automatically loading and unloading the scale with test weights, when the auto span function is initiated from remote.

Default: 10% 10 sec
Min: 0 % 0 sec
Max: 105 % 90 sec

```
- ALARM SCROLL 1B -  
High rate set  
100 % 10 sec  
ENTER SET/DELAY UNITS/%
```

Password: Operator

Default: 10 % 10 sec
Min: 0 % 0 sec
Max: 150 % 90 sec

2. Define Load Alarm

Use the **CHOICE** key to turn on or off the belt loading alarm. Confirm with **ENTER**.

```
- ALARM SCROLL 2 -  
Load Alarm  
> NO <  
CHOICE ENTER
```

Password: Operator

Default: NO
Selections: YES, NO

If the selection in the previous screen was YES, enter the low and high setpoints for the alarm. Also enter the desired delay time before the alarm is monitored. The **UNITS** key allows the user to specify the setpoints in engineering units, the % key selects percent. The **SET/DLY** switches between the setpoint and the delay time.

```
- ALARM SCROLL 2A -  
Low load set  
10 % 10 sec  
ENTER SET/DELAY UNITS/%
```

Password: Operator

Default: 10% 10 sec
Min: 0 % 0 sec
Max: 105 % 90 sec

```
- ALARM SCROLL 2B -  
High load set  
100 % 10 sec  
ENTER SET/DELAY UNITS/%
```

Password: Operator

Default: 100% 10 sec
Min: 0 % 0 sec
Max: 200 % 90 sec

3. Define Speed Alarm

Use the **CHOICE** key to turn on or off the belt speed alarm. Confirm with **ENTER**.

```
- ALARM SCROLL 3 -  
Speed Alarm  
> NO <  
CHOICE ENTER
```

Password: Operator

Default: NO
Selections: YES, NO

If the selection in the previous screen was **YES**, enter the low and high setpoints for the alarm. Also enter the desired delay time before the alarm is monitored. The **UNITS** key allows the user to specify the setpoints in engineering units, the % key selects percent. The **SET/DLY** switches between the setpoint and the delay time.

```
- ALARM SCROLL 3A -  
Low speed set  
10 % 10 sec  
ENTER SET/DELAY UNITS/%
```

Password: Operator

Default: 10% 10 sec
Min: 0 % 0 sec
Max: 105 % 90 sec

```
- ALARM SCROLL 3B -  
High speed set  
100 % 10 sec  
ENTER SET/DELAY UNITS/%
```

Password: Operator

Default:	100%	10 sec
Min:	0 %	0 sec
Max:	150 %	90 sec

If the Speed Mode that was defined in Main Menu 2, Scale Data, is **DUAL**, the user has to enter the maximum acceptable difference in percent between the two speed inputs, and the delay time before the alarm is generated.

```

- ALARM SCROLL 4A -
Belt slip set
  1 %  10 sec
ENTER SET/DELAY UNITS/%

```

Password: Operator

Default:	1 %	10 sec
Min:	0 %	0 sec
Max:	100 %	90 sec

4. Setup Alarm Modes

The following message is displayed for three seconds.

```

- ALARM SCROLL 5
- ALARM DEFINITION -
Use NEXT key or
enter alarm number

```

After three seconds, the following screen is displayed. The user can use the **CHOICE** soft key to select the desired mode between **ALARM** (just a warning message), **SHUT DOWN** (Warning plus fault output) and **NONE** (no action). Confirm with **ENTER**. Use the **NEXT** key to scroll between alarms, or enter the alarm number.

```

ALARM NUMBER #. 1
Clock Fail
set as ALARM
CHOICE  ENTER  NEXT

```

Alarms are listed in Chapter 4.0, Maintenance.

4.5 MAIN MENU 5

Main Menu 5 is dedicated to the serial options. **COMM A** is used to set up the serial line of the optional board Communication A, and **PRINT** is used for setting up the printer output. Main Menu 5 does not appear unless an optional COMM A is installed.

```
- MAIN MENU 5 -  
Press MENU for more  
  
COMM A          PRINT
```

4.5.1 Communication A Scroll

The communication board A has one serial channel, which can be configured using jumpers as an RS232 or an RS485 channel. The serial channel can be used for printing or for a serial communication with an intelligent device such as a PLC or a PC. Two COMM A boards can be installed and programmed, typically one for the printer and one for the supervisor.

The following screens define the communication parameters for the first and the second channel.

```
- COMM. A SCROLL 1 -  
Baud rate port #1  
> 9600 <  
CHOICE ENTER
```

Password: Service

Default: 9600
Selections: 110, 150, 300, 600, 1200, 2400, 4800, 9600, 19200

```
- COMM. A SCROLL 2 -  
Set parity port #1  
> No parity <  
CHOICE ENTER
```

Password: Service

Default: NO PARITY
Selections: EVEN PARITY, ODD PARITY, NO PARITY

```
- COMM. A SCROLL 3 -  
Stop bits port #1  
> 1 stop bit <  
CHOICE ENTER
```

Password: Service

Default: 1 STOP BIT
Selections: 1 STOP BIT, 2 STOP BITS

```
- COMM. A SCROLL 4 -  
Wordlength port #1  
> 8 bits <  
CHOICE ENTER
```

Password: Service

Default: 8 BITS
Selections: 7 BITS, 8 BITS

Some commonly used protocols are implemented in the system. See Communication Protocols, REC 3949, for the details. Possible selections are:

PC-MASTER	Ramsey proprietary protocol: Multi Drop, Master Slave.
SIEMENS 3964R	A proprietary protocol of Siemens. Point to point, Multi Master.
ALLEN BRADLEY DF1	A proprietary protocol of Allen Bradley. Multi Drop, Master Slave.
MODBUS	A proprietary protocol of AEG. Multi Drop, Master Slave.
PRINTER	Not a protocol, selects printer output.

```
-COMM. A SCROLL 5 -  
Protocol port #1  
> MODBUS <  
CHOICE ENTER
```

Password: Service

Default: MODBUS
Selections: PC-MASTER, SIEMENS 3964R, ALLEN BRADLEY DF1, MODBUS, PRINTER

If the selected protocol is not PRINTER, the following screens define the ADDRESS of the device in the multi drop line, and the access permission from the remote supervisor. If NONE is selected, the supervisor has full access to the device. If LIMITED is selected, the supervisor only accesses those variables that are accessible with the OPERATOR password. If PROTECTED is selected, the unit is write protected.

```
-COMM. A SCROLL 5A -  
Clear to send #1  
> disabled <  
CHOICE ENTER
```

Password: Service

Default: DISABLED
Selections: DISABLED, ENABLED

```
-COMM. A SCROLL 6 -  
Address port #1  
1  
ENTER
```

Password: Service

Default: 1
Min: 1
Max: 255

```
-COMM. A SCROLL 7 -  
Access prot. port #1  
> None <  
CHOICE ENTER
```

Password: Service

Default: NONE
Selections: NONE, LIMITED, PROTECTED

If a second communication board is installed, the following screen appears. These screens operate exactly as the ones dedicated to the communication board 1.

```
- COMM. A SCROLL 8 -  
Baud rate port #2  
> 2400 <  
CHOICE ENTER
```

Password: Service

Default: 9600
Selections: 110, 150, 300, 600, 1200, 2400, 4800, 9600, 19200

```
- COMM. A SCROLL 9 -  
Set parity port #2  
> No parity <  
CHOICE ENTER
```

Password: Service

Default: NO PARITY
Selections: NO PARITY, EVEN PARITY, ODD PARITY

```
- COMM. A SCROLL 10 -  
Stop bits port #2  
> 1 stop bit <  
CHOICE ENTER
```

Password: Service

Default: 1 STOP BIT
Selections: 1 STOP BIT, 2 STOP BITS

```
- COMM. A SCROLL 11-  
Wordlength port #2  
> 8 bits <  
CHOICE ENTER
```

Password: Service

Default: 8 BITS
Selections: 7 BITS, 8 BITS

```
-COMM. A SCROLL 12 -  
Protocol port #2  
> MODBUS <  
CHOICE ENTER
```

Password: Service

Default: MODBUS
Selections: PC MASTER, SIEMENS 3964R, ALLEN BRADLEY DF1,
MODBUS, PRINTER

Only if protocol of port #2 is not PRINTER:

```
- COMM. A SCROLL 12A  
Clear to send #2  
> Disabled <  
CHOICE ENTER
```

Password: Service

Default: DISABLED
Selections: DISABLED, ENABLED

```
- COMM. A SCROLL 13-  
Address port #2  
1  
ENTER
```

Password: Service

Default: 1
Min: 1
Max: 255

```
- COMM. A SCROLL 14-  
Access prot. port #2  
> None <  
CHOICE ENTER
```

Password: Service

Default: NONE
Selections: NONE, LIMITED, PROTECTED

4.5.2 Print

The Micro-Tech 2000 has a fully programmable printer format. The following section explains how to program it according to the specific needs.

1. Define Handshaking

The system can be configured to operate without any handshake (NONE), or using the Clear to Send signal (CTS) or the XON-XOFF sequence. Refer to the printer instruction manual to define which selection is required. The selection NONE is only used for testing purposes. It is not recommended for normal use. If NONE is selected, the system is not able to recognize if the printer is on line or not, or if the paper is empty.

The most commonly used protocol is the CTS, which is a signal generated by the printer to indicate whether it is ready to receive data or not.

```
-PRINTER SCROLL 1 -  
Handshaking  
> None <  
CHOICE ENTER
```

Password: Service

Default: NONE
Selections: NONE, CTS, XON-XOFF

Different printers use different end of line patterns. Select the one you need for your printer.

```
-PRINTER SCROLL 2 -  
End of line  
> CR <  
CHOICE ENTER
```

Password: Service

Default: CR
Selections: CR, LF, CR+LF

Some printers cannot accept characters while they are printing. In some cases, the handshake is not well controlled by the printer, so a delay at end of line is helpful.

```
-PRINTER SCROLL 3 -  
Delay end of line  
  0 sec  
ENTER
```

Password: Service

Default: 0 sec
Min: 0 sec
Max: 5 sec

A form feed character can be sent to the printer after each report to force the printer to eject the paper. If NO is selected, a normal END OF LINE character(s) is printed at the end of the report.

```
-PRINTER SCROLL 4 -  
Form Feed  
> NO <  
CHOICE ENTER
```

Password: Service

Default: NO
Selections: NO, YES

2. Periodical Printing

If you want to generate periodical printing, enter the number of minutes, hours or days in the following screen. By entering 0, the periodical printing is prevented. Use the INTV key to switch from minutes to hours and to days.

```
-PRINTER SCROLL 5 -  
Print interval  
  0 min  
ENTER          INTV
```

Password: Operator

Default: 0 min
Min: 0 min, 0 hour, 0 days
Max: 59 min, 23 hour, 365 days

The system can print at specific times during the day. Enter the time you want to obtain the printing. Use the NEXT key to scroll between the print times (maximum 4). The ON/OFF key enables or disables the displayed print time.

```
-PRINTER SCROLL 6 -  
Print time # 1  
time HH:MM  
ENTER ON/OFF NEXT
```

Password: Operator

	If 24 hours	If am/pm
Default:	OFF	OFF
Min:	00:00	01:00
Max:	23:59	12:59

3. Define Print Format

By selecting YES in the following screen, the system is instructed to print one line each time a new alarm condition occurs. The alarm is printed as follows:

```
xx-xx-xxxx yy:yyz
kkkkkkkkkkkkkkkkkkkk
```

where:

xx-xx-xxxx

Day, Month, Year, printed according to the local format as defined in Main Menu 2 - Display Scroll, Section 4.2 of this Appendix.

yy:yyz

Hour, Minutes, am/pm printed according to the local format as defined in Main Menu 2 - Display Scroll, Section 4.3 of this Appendix.

kkkkkkkkkkkkkkkkkkkk

Alarm message, same message appearing on the screen

For example:

01-22-1998 8:14a

Clock Fail

```
- PRINTER SCROLL 7 -
Print alarms
> No <
CHOICE ENTER
```

Password: Service

Default: NO

Selections: YES, NO

There are three ways for defining the printing format. The first two are predefined formats, which are as follows:

DEFAULT 1
TOTALS REPORT

DATE: 01-22-1998

TIME: 8:12a

MASTER TOTAL: 0.00 Tons

RESET TOTAL: 0.00 Tons

OPERATOR TOTAL: 0.00 Tons

RATE: 0.00 Tph

DEFAULT 2

DATE: 01-22-1998
TIME: 8:12a

MASTER START TOTAL: 0.00 Tons
MASTER STOP TOTAL: 0.00 Tons
QUANTITY: 0.00 Tons

The format "DEFAULT 2" is preselected when the weights and measures choice is NTEP.

The third way is to define your own format using the printer setup screens listed below.

Select **DEFAULT** if you want the predefined format. Select **USER DEFINED** if you want to set up your own format.

<pre>- PRINTER SCROLL 8 - Total report format > <u>Default 1</u> < CHOICE ENTER</pre>	Password: Service
---	-------------------

Default: DEFAULT 1 unless Weights and Measures option is selected, then DEFAULT 2.
Selections: DEFAULT 1, DEFAULT 2, USER DEFINED

If your selection is USER DEFINED, the following screens are displayed.

First, define the number of strings that you want to add to your report. You can enter a number from 1 to 3. Strings can be used to add the company name as well as other information that you want to include in the print format.

<pre>- PRINTER SCROLL 9A- Number of strings <u>3</u> ENTER</pre>	Password: Operator
--	--------------------

Default: 1
Min: 0
Max: 3

If you specified a number of strings larger than zero, you can now enter the strings. Use the alphanumeric keypad, pressing the numeric key corresponding to the letter that you want to type. Every time you press a new key, the cursor moves to the right one place. If you need to use two times the same key (example for double letters), move the cursor right using the arrow keys (left and right soft keys).

```

- PRINTER SCROLL 9B -
Contents string #1
XXXXXXXXXXXXXXXXXXXXX
< ENTER >

```

Password: Operator

Default: XXXXXXXXXXXXXXXXXXXX

Once you have defined the string, specify where the string has to be placed on the printed report. The coordinate is given in the following way:

```

00000000001111111112222222223...
0123456789012345678901234567890...
+-----> Y
00|This line printed first
01|This line printed second      ^
02|                               | DIRECTION OF
03|                               | PAPER
04|
05|
06|
.v
.X

```

Use the **X-pos** and **Y-pos** keys to enter the X and Y coordinates. Confirm with **ENTER**. By specifying 0,0, the string is not printed.

```

- PRINTER SCROLL 9C -
Position string #1
X = 0 , Y = 0
ENTER      X\Y-pos

```

Password: Operator

	X	Y
Default:	1,	1
Min:	0,	1
Max:	24,	80

If you specified more strings, enter the relevant data using the same procedure.

```

- PRINTER SCROLL 9D -
Contents string #2
XXXXXXXXXXXXXXXXXXXXX
< ENTER >

```

Password: Operator

Default: xxxxxxxxxxxxxxxxxxxxxx

```
- PRINTER SCROLL 9E -  
Position string #2  
X = 0, Y = 0  
ENTER      X\Y-pos
```

Password: Operator

	X	Y
Default:	2,	1
Min:	0,	1
Max:	24,	80

```
- PRINTER SCROLL 9F -  
Contents string #3  
xxxxxxxxxxxxxxxxxxxxxxxx  
< ENTER >
```

Password: Operator

Default: xxxxxxxxxxxxxxxxxxxxxx

```
- PRINTER SCROLL 9G -  
Position string #3  
X = 0, Y = 0  
ENTER      X\Y-pos
```

Password: Operator

	X	Y
Default:	3,	1
Min:	0,	1
Max:	24,	80

```
- PRINTER SCROLL 9H -  
Position oper. total  
X: 0  Y: 0  
ENTER  X-Pos  Y-Pos
```

Password: Operator

	X	Y
Default:	4	1
Min:	0	1
Max:	24	80

In a similar way, you can position the following variables in the print format:

The Reset Total:

```
- PRINTER SCROLL 9I -  
Position reset total  
X: 0   Y: 0  
ENTER  X-Pos   Y-Pos
```

Password: Operator

	X	Y
Default:	5	1
Min:	0	1
Max:	24	80

The Master Total:

```
- PRINTER SCROLL 9J -  
Position master total  
X: 0   Y: 0  
ENTER  X-Pos   Y-Pos
```

Password: Operator

	X	Y
Default:	6	1
Min:	0	1
Max:	24	80

The Current Date:

```
- PRINTER SCROLL 9K -  
Position date  
X = 0 , Y = 0  
ENTER  X-Pos   Y-Pos
```

Password: Operator

	X	Y
Default:	7,	1
Min:	0,	1
Max:	24,	80

The Current Time:

```
- PRINTER SCROLL 9L-  
Position time  
X = 0 , Y = 0  
ENTER  X-Pos   Y-Pos
```

Password: Operator

	X	Y
Default:	8,	1
Min:	0,	1
Max:	24,	80

The Instantaneous Value of Rate:

<pre> - PRINTER SCROLL 9M- Position rate X = <u>0</u> , Y = <u>0</u> ENTER X-Pos Y-pos </pre>	Password: Operator
---	--------------------

	X	Y
Default:	9,	1
Min:	0,	1
Max:	24,	80

The Average Rate Since the Last Print:

The average rate is calculated only on the periods of time in which rate has been higher than 5% of capacity.

<pre> - PRINTER SCROLL 9N- Position avg. rate X = <u>0</u> , Y = <u>0</u> ENTER X-Pos Y-Pos </pre>	Password: Operator
--	--------------------

	X	Y
Default:	9,	1
Min:	0,	1
Max:	24,	80

The Running Time Since the Last Print:

The running time is the time in which rate has been higher than 5%.

<pre> - PRINTER SCROLL 9P- Position running tm X = <u>0</u> , Y = <u>0</u> ENTER X-Pos Y-Pos </pre>	Password: Operator
---	--------------------

	X	Y
Default:	0,	1
Min:	0,	1
Max:	24,	80

If the optional load out board is installed, the batch quantity and the batch total can also be printed.

4.5.3 The PRINT Key

If the optional COMM board is installed, the **PRINT** key enables the printer to print data.

The following screen is displayed:

```
- PRINTER SCROLL -  
COM #1 no data  
Start print TOTALS  
PRINT RETURN COM
```

Password: Not Required

The second line gives the status of the printer:

NO DATA Indicates the printer is idle, no data are being sent to the printer.

IS RUNNING The system is sending data to the printer.

The third line indicates what kind of data is printed if the **PRINT** key is pressed. The **UP** and **DOWN** keys select between:

TOTALS Print totals.

BATCH Only if load out option is active, print load out information.

SETUP Print the setup data of the instrument.

TRAILS If audit trails option is active, print audit trails data.

Print starts after the **PRINT** key is pressed.

The **COM** key allows the operator to select the printer in case more than one is installed.

Here are some examples of data that can be printed:

```
Print TOTALS  
TOTALS REPORT  
DATE: 01-22-1998  
TIME: 8:12a  
  
MASTER TOTAL: 0.00 Tons  
RESET TOTAL: 0.00 Tons  
OPERATOR TOTAL: 0.00 Tons  
RATE: 0.00 Tph
```

Print BATCH:
BATCH REPORT

DATE: 01-22-1998
TIME: 8:12a

BATCH NR: 0
SET PT: 0.00 Tons
TOTAL: 0.00 Tons

Print ALARM:
01-22-1998 8:14a
Clock fail

Print SETUP:
INSTRUMENT SETUP
The system prints out all data and setups.

Print AUDIT TRAILS:
TRAIL RECORD NR 1
DATE 01-22-1998 TIME 11:59
VARIABLE scale cap
NEW 400.00
OLD 500.00

TRAIL RECORD NR 2
DATE 01-22-1998 TIME 11:31
VARIABLE span
NEW 250000
OLD 300000

TRAIL RECORD NR 3
DATE 01-22-1998 TIME 11:59
VARIABLE div (e)
NEW 0.05
OLD 0.1

4.6 MAIN MENU 6

Main Menu 6 is dedicated to Audit Trails and Linearization.

```
- MAIN MENU 6 -  
Press MENU for more  
AUDIT  
TRAIL    LINEAR
```

4.6.1 Audit Trail

This menu is only displayed if the Audit Trails option is installed.

Audit trail meets NIST HB 44 Category 3: Remote configuration capability, access may be unlimited or controlled through a password. It consists of an event logger that includes an event counter (000 to 999), the parameter description, the date and time of the change, and the old and new value of the parameter. Parameters may be configuration parameters or routine calibration.

Events and changes may be viewed on the Integrator's display or printed out by an on-site printer.

The logger records the before and after setting of all configuration parameters that affects the calibration of the scale. It also records when calibration was performed. The event counter increments one count for each event.

Audit trail records the time and displays the new and old data for any change in the items below, indicating each by an event number:

ZERO
SPAN
CALIBRATION METHOD
CHAIN WEIGHT
TEST WEIGHT
SCALE CAPACITY
SCALE DIVISION
SCALE MODEL NO.
IDLER SPACING
INCLINATION
LOAD CELL SIZE
LOAD CELL SENSITIVITY
LOAD CELL RESISTANCE
SPEED INPUT TYPE
DEAD BAND
MEASURE UNITS
REMOTE COUNTER DIVIDER
REMOTE COUNTER DURATION
AZT TRACKING RANGE

LINEARIZATION

NOTE: Changes in zero by auto zero tracking are not recorded. However, if AZT limit is reached, is recorded.

```
- AUDIT TRAILS 1 -  
Audit trails  
NO  
CHOICE ENTER
```

Password: Service

Default: No
Selections: Yes, No

If the audit trails are enabled, meaning YES is selected, the following screen appears for a short time (3 seconds):

```
- AUDIT TRAILS -  
Use scroll keys or  
enter trail number
```

After 3 seconds, the next screen is shown:

```
TRAIL EVENT No. 0000  
hh:mm      dd-mm-yyyy  
nnnnnn = vvvvvvv/N  
nnnnnn = vvvvvvv/O
```

hh:mm	Time of change
dd-mm-yyyy	Date of change
nnnnnn	Parameter's name
vvvvv	Parameter's values, after change new (N) and before change old (O)

Time and date are shown only if an optional Communication board is installed.

The user can scroll between events which are displayed in order of date and time. The user can also enter a number to display a specific event.

4.6.2 Linearization

Linearization is not normally used with conveyor belt scales. In case of extreme instances where calibration at multiple flow rates may be required, please consult the factory.

APPENDIX A/6 MT2001 MULTI-POINT CALIBRATION

6.0 GENERAL

This appendix contains setup and calibration menus for establishing multiple calibration factors, both zero and span, for the weighing system.

Variations in conveyor belt tension affect the accuracy capabilities of a conveyor belt scale. Causes of these variations may be the use of a reversing belt, multiple feed points, or multiple products being conveyed that have a significant difference in bulk density. In order to compensate for these changes in the system operation, and to maintain weighing accuracy under varying mechanical influences, different calibration factors may be used.

Up to 10 different calibration points are possible. Each calibration point will have its own zero number, span number, and linearization table. To configure the linearization table, refer to Appendix A/2 (REC-3909). The different calibration points are accessible through the front panel keyboard or via a digital input. When a calibration number is selected, all of its associated values immediately become active.

6.1 DEFINE NUMBER OF CALIBRATION POINTS

During the initial programming (cold start) of the integrator a theoretical zero and span are computed and applied to all of the calibration points. From this point on, any zero or span calibration that is performed changes only the currently active calibration point.

Enabling multiple calibration points is performed through CAL DATA scroll. Press **MENU**, **MENU**, **CALIB. DATA** and scroll down until the following screen is displayed.

```
-CAL DATA SCROLL 14-  
Number of calib.  
      1  
ENTER
```

Password: Operator

Default: 1
Minimum: 1
Maximum: 10

If number of calibrations selected is greater than 1, the scale symbol is added in the RUN display with the active calibration number, as indicated below.

```
      123.0 Tons  
      0.0 Tph  
  
  [Scale Symbol]
```

6.2 SELECTION OF CALIBRATION POINT

From 1 to 10 different calibrations can be programmed into the Micro-Tech 2101 Integrator. After selecting the number of calibrations as outlined in Appendix A/6, Section 6.1, it is necessary to determine which calibration corresponds with a particular operating mode. The calibration number can be activated via the front panel keyboard or via a remote digital input.

Front Panel Keyboard

To change calibration number from the front panel keyboard, press the  soft key. The following screen is displayed.

```
SELECT CALIBRATION
Calib. Number
      1
ENTER
```

Enter the calibration number to be activated and press the **ENTER** soft key. Return to the main RUN MENU. The active calibration number will now be in the lower left hand portion of the screen. If an auto or manual zero or a manual or automatic span is performed at this time, only the active calibration number is affected.

NOTE: If digital inputs are assigned to select calibration numbers, the calibration number cannot be changed via the front panel keyboard. Attempting to do so results in the following screen being displayed.

```
Selection calib.
In remote mode.

RETURN
```

Digital Input Selection

When the number of calibrations selected is greater than 1, scrolls are added to the Digital Input Define (Dig. input def.). Scroll in I/O DEF SCROLL 4 as indicated below:

```
- I/O DEF SCROLL 4 -
Dig. Input Def.
CAL. Sel 2      0 NC
ENTER  NC/NO  NEXT
```

The number of Cal Sel ____ inputs is equal to the number of calibration numbers. When an input is activated, the corresponding calibration number and associated zero, span, and linearization table is also activated. In the event that more than one input is activated, the first input active will be used.

When an auto zero or auto span is executed, the results are saved to the active calibration number. Once a calibration test has been initiated, changing the active calibration number via the digital inputs will have no effect; the calibration factors, zero, or span will be saved to the calibration number that was active at the beginning of the test.

Linearization

In the linearization scroll, the table of linearization factors displayed are only for the active calibration number.

APPENDIX

<u>NO.</u>	<u>TITLE</u>	
A/1	Ramsey Weighbridge Physical Parameters	
A/2	Linearization (Request REC 3909 from factory)	
A/3	Digital Input/Output Module	
A/4	MT2101 Menus	
* A/5	Load Out	REC 3910
A/6	MT2101 Multi-Point Calibration	
A/7	Menu Tree Drawings (Sheets 1 through 4)	C07257B-V100

* If option is supplied.

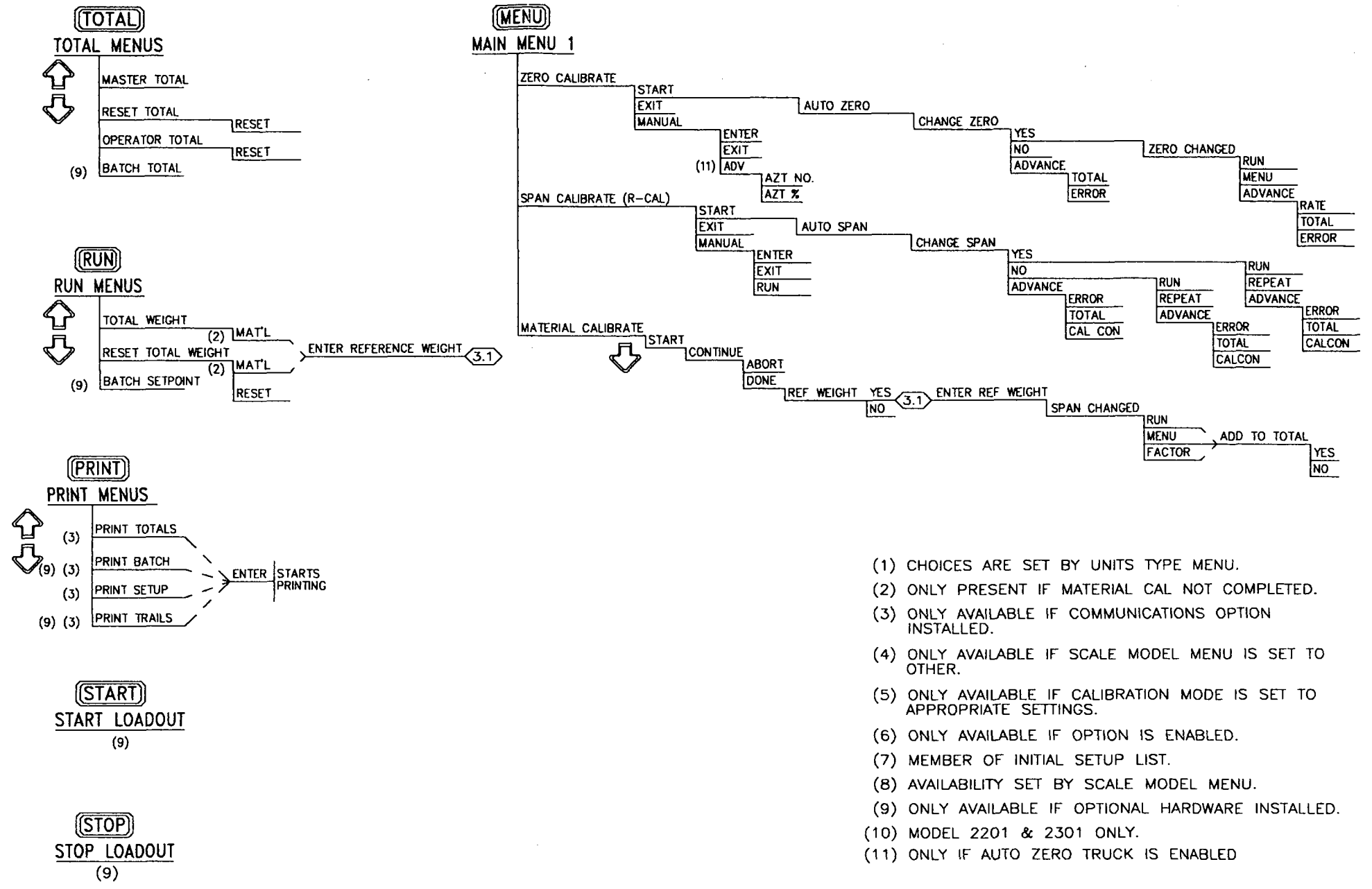

- (1) CHOICES ARE SET BY UNITS TYPE MENU.
- (2) ONLY PRESENT IF MATERIAL CAL NOT COMPLETED.
- (3) ONLY AVAILABLE IF COMMUNICATIONS OPTION INSTALLED.
- (4) ONLY AVAILABLE IF SCALE MODEL MENU IS SET TO OTHER.
- (5) ONLY AVAILABLE IF CALIBRATION MODE IS SET TO APPROPRIATE SETTINGS.
- (6) ONLY AVAILABLE IF OPTION IS ENABLED.
- (7) MEMBER OF INITIAL SETUP LIST.
- (8) AVAILABILITY SET BY SCALE MODEL MENU.
- (9) ONLY AVAILABLE IF OPTIONAL HARDWARE INSTALLED.
- (10) MODEL 2201 & 2301 ONLY.
- (11) ONLY IF AUTO ZERO TRUCK IS ENABLED

CADD DATABASE: AUTOCAD

REV	ECO NO	MICRO	DESCRIPTION	DATE	BY	APPD
F	1810		UPDATED TO VERSION 33.00.03.05 SOFTWARE	8-9-99	IMAK	WMR
E	1439		ADDED AZT & COM B SCROLLS	1-7-99	VCP	WMR
D	1309		ADDED MODEL 2201 TO NOTE 10	10-29-97	VCP	WMR
C	0762		MOVE RESET FROM MASTER TOTAL TO RESET TOTAL	1-21-98	EBJ	WMR
B	0118		ADD NOTE 10; CHG NOTE 6	1-30-97	EBJ	WMR
A	9053		RELEASED	10-27-95	TD	WMR

DO NOT SCALE DWG REMOVE ALL BURRS AND UNNECESSARY SHARP EDGES	SCALE NONE JOB NO	<small>This document is confidential and is the property of Ramsey Technology Inc. ("Ramsey"). It may not be copied or reproduced in any way without the expressed written consent of Ramsey. This document also is an unpublished work of Ramsey. Ramsey intends to and is maintaining the work as confidential information. Ramsey also may seek to protect this work as an unpublished copyright. In the event of other trademark or database protection, Ramsey intends to enforce its rights to this work under the copyright laws as a published work. Those having access to this work may not copy, use or disclose the information in this work unless expressly authorized by Ramsey.</small>				
TOLERANCE UNLESS SPECIFIED .X ± .06 .XX ± .03 .XXX ± .01 FRACT. ± 1/16 ANGLES ± 1/2°	ENG GR DATE 9-13-95 DWN TD DATE 9-14-95 CHK MCC DATE 9-21-95	 501 - 90th Avenue N.W. • Minneapolis, MN 55433 • (612)783-2500 A Thermo Scantron company MENU SELECTIONS MICRO-TECH 2000 INTEGRATOR SHEET 1 OF 4				
NEXT ASS'Y CUST ORDER NO	CUSTOMER LOCATION USER LOCATION					
REV	ECO NO	MICRO	DESCRIPTION	DATE	BY	APPD
PART NO		DRAWING NUMBER		REV		
		C07257B-V100		F		

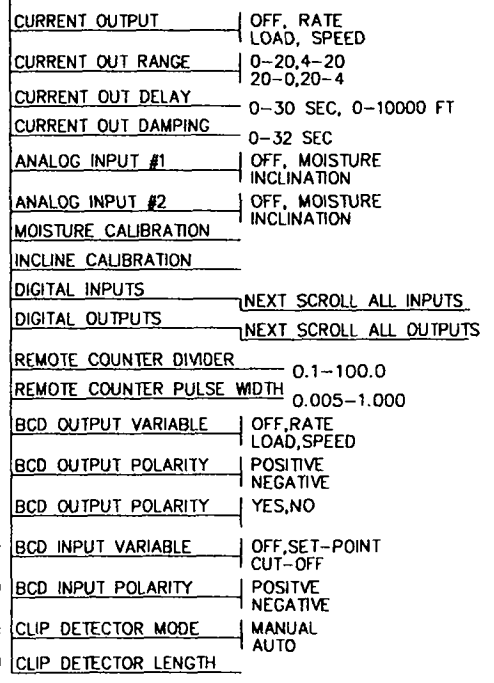
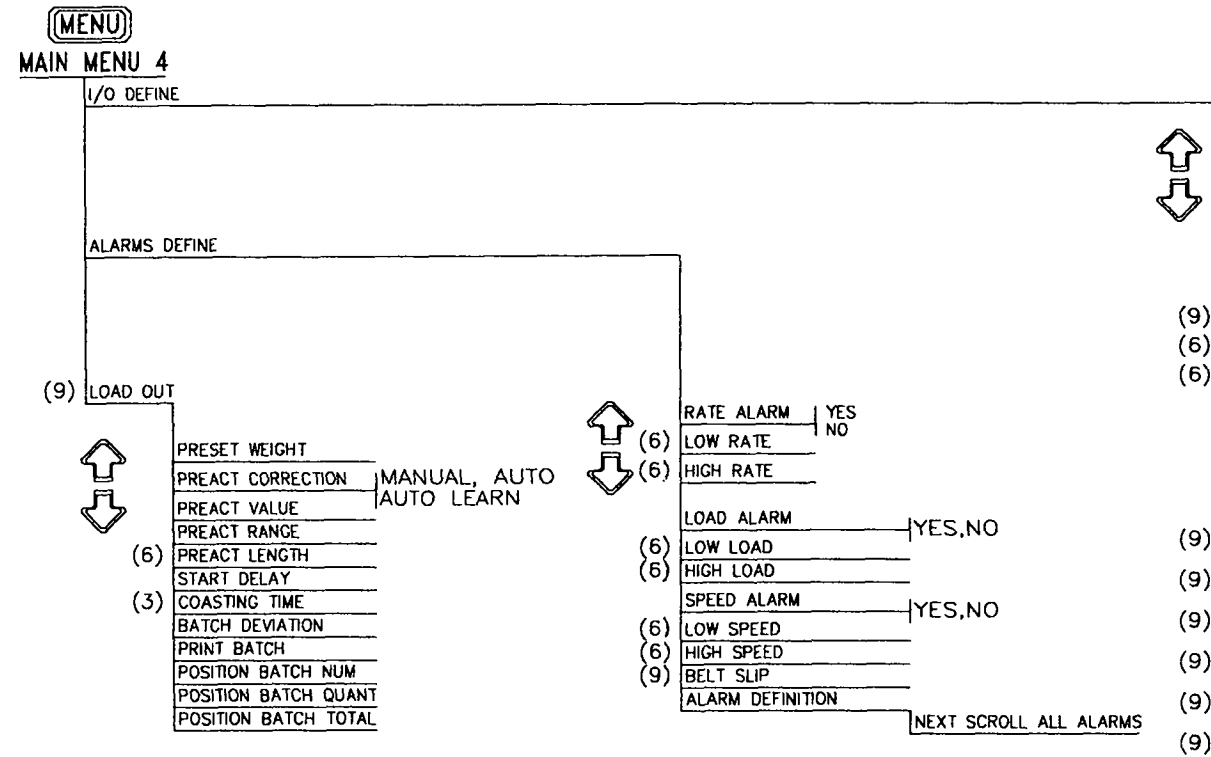
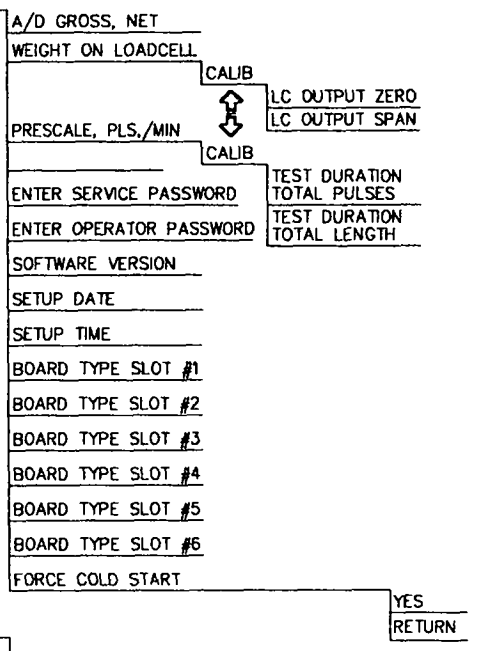
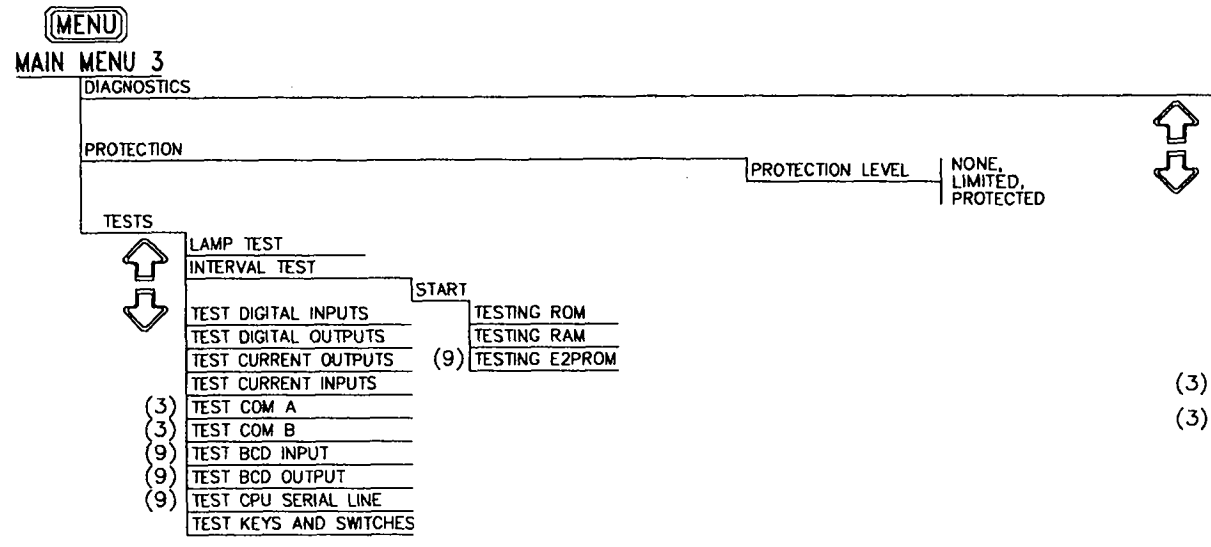

CADD DATABASE: AUTOCAD

DO NOT SCALE DWG		SCALE NONE	
REMOVE ALL BURRS AND UNNECESSARY SHARP EDGES		JOB NO	
TOLERANCE UNLESS SPECIFIED		ENG GR	DATE 9-13-95
.X ± .06		DWN TD	DATE 9-14-95
.XX ± .03		CHK MCC	DATE 9-21-95
.XXX ± .01			
FRACT. ± 1/16			
ANGLES ± 1/2°			
NEXT ASS'Y			
CUST ORDER NO			
CUSTOMER LOCATION			
USER LOCATION			

This document is confidential and is the property of Ramsey Technology Inc. ("Ramsey"). It may not be copied or reproduced in any way without the express written consent of Ramsey. The document also is an unpublished work of Ramsey. Ramsey intends to and is maintaining the work as confidential information. Ramsey also may seek to protect this work as an unpublished copyright. In the event of other independent or otherwise published work, Ramsey intends to enforce its rights to this work under the copyright law as a published work. Those having access to this work may not copy, use or disclose the information in this work unless expressly authorized by Ramsey.



A Thermo Sentron company
 MENU SELECTIONS
 MICRO-TECH 2000
 INTEGRATOR
 SHEET 3 OF 4

PART NO	DRAWING NUMBER	REV
	C07257B-V100	F

REV	ECO NO	MICRO	DESCRIPTION	DATE	BY	APPD
			SEE SHEET 1			

(MENU)
MAIN MENU 5

- (3) COMM A
- (9) AB RIO OR PROFIBUS DP
- (6) (3) PRINT
 - HANDSHAKING NONE
CTS,XON-XOFF
 - END OF LINE CR
LF,CR+LF
 - DELAY END OF LINE
 - FORM FEED YES
NO
 - PRINT INTERVAL
 - PRINT TIME 1
 - PRINT ALARMS NEXT
YES
NO
 - TOTALS REPORT FORMAT DEFAULT 1
DEFAULT 2
USER DEFINED
 - (6) NUMBER OF STRINGS
 - (6) CONTENTS STRING 1
 - (6) POSITION STRING 1
 - (6) CONTENTS STRING 2
 - (6) POSITION STRING 2
 - (6) CONTENTS STRING 3
 - (6) POSITION STRING 3
 - (6) POSITION OPERATOR TOTAL
 - (6) POSITION RESET TOTAL
 - (6) POSITION MASTER TOTAL
 - (6) POSITION DATE
 - (6) POSITION TIME
 - (6) POSITION RATE
 - (6) POSITION AVG RATE
 - (6) POSITION RUNNING TM

AB RIO

PROFIBUS DP

ADDRESS
READ BUFFER DIM
WRITE BUFFER DIM

BAUD RATE 57.6
115.2
230.4

SLAVE ADDRESS RACK
QUARTER

RESET

- BAUD RATE 1 110,150,300,600,1200,2400,
4800,9600,19200,38400
- PARITY 1 EVEN,ODD
NONE
- STOP BITS 1 1,2
- WORD LENGTH 1 7,8
- (6) PROTOCOL 1 PC-MASTER,SIEMENS,
ALLEN BRADLEY,MODBUS,PRINTER
- (6) CTS 1 ENABLED
DISABLED
- (6) ADDRESS 1
- (6) ACCESS 1 NONE,LIMITED
PROTECTED
- (6) BAUD RATE 2 110,150,300,600,1200,2400,
4800,9600,19200,38400
- (6) PARITY 2 EVEN,ODD
NONE
- (6) STOP BITS 2 1,2
- (6) WORD LENGTH 2 7,8
- (6) PROTOCOL 2 PC-MASTER,SIEMENS,
ALLEN BRADLEY,MODBUS,PRINTER
- (6) CTS 2 ENABLED
DISABLED
- (6) ADDRESS 2
- (6) ACCESS 2 NONE,LIMITED
PROTECTED

(MENU)
MAIN MENU 6

- (9) AUDIT TRAIL
 - AUDIT TRAIL YES
NO
 - TRAIL EVENTS
- LINEARIZATION
 - LINEARIZATION YES
NO
 - (6) LIN FACTOR #1
 - (6) LIN FACTOR #2
 - (6) LIN FACTOR #3
 - (6) LIN FACTOR #4
 - (6) LIN FACTOR #5

CADD DATABASE: AUTOCAD

DO NOT SCALE DWG	SCALE NONE
REMOVE ALL BURRS AND UNNECESSARY SHARP EDGES	JOB NO
TOLERANCE UNLESS SPECIFIED	ENG GR DATE 9-13-95
.X ± .06	DWN TD DATE 9-14-95
.XX ± .03	CHK MCC DATE 9-21-95
.XXX ± .01	
FRACT. ± 1/16	
ANGLES ± 1/2°	
NEXT ASS'Y	
CUST ORDER NO	
CUSTOMER LOCATION	
USER LOCATION	

This document is confidential and is the property of Ramsey Technology Inc. ("Ramsey"). It may not be copied or reproduced in any way without the expressed written consent of Ramsey. This document also is an unpublished work of Ramsey. Ramsey intends to use in maintaining the work as confidential information. Ramsey also may wish to protect this work as an unpublished copyright. In the event of other independent or derivative publications, Ramsey intends to enforce it's rights to this work under the copyright laws as a published work. Those having access to this work may not copy, use or disclose the information in this work unless expressly authorized by Ramsey.



A Thermo Santron company
MENU SELECTIONS
MICRO-TECH 2000
INTEGRATOR
SHEET 4 OF 4

PART NO	DRAWING NUMBER	REV
	C07257B-V100	F

REV	ECO NO	MICRO	DESCRIPTION	DATE	BY	APPD
			SEE SHEET 1			